

PERFORMANCE SPECIFICATION

CAPACITORS, FIXED, CERAMIC DIELECTRIC,  
(TEMPERATURE STABLE AND GENERAL PURPOSE), HIGH RELIABILITY,  
GENERAL SPECIFICATION FOR

This specification is approved for use by all Departments  
and Agencies of the Department of Defense.

1. SCOPE

1.1 Scope. This specification covers the general requirements for high reliability, general purpose (BX and BR) and temperature stable (BP and BG) ceramic dielectric fixed capacitors, leaded and nonleaded for space, missile, and other high reliability applications. Capacitors covered by this specification may be used in critical frequency determining applications, timing circuits, and other applications where absolute stability is required (BP and BG), and in applications where appreciable variations in capacitance with respect to temperature, voltage, frequency, and life can be tolerated (BX and BR). Life tests in this specification are performed at two times rated voltage at maximum rated temperature, and an assumed acceleration factor of 8:1 is used to relate life test data obtained at two times rated voltage to performance at rated voltage.

1.2 Classification.

1.2.1 Part or Identifying Number (PIN). Capacitors specified herein (see 3.1) are identified by a PIN which consists of the basic number of the performance specification sheet followed by a series of coded characters. Each performance specification sheet covers a different capacitor style. The coded number provides information concerning the capacitors' characteristic, working voltage, capacitance value, capacitance tolerance, and termination material. The PIN is in the following form:

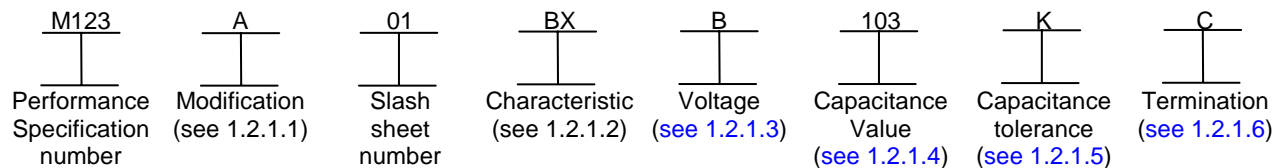

1.2.1.1. Modification. The modification letter is used to indicate the latest characteristic of the part in the specification sheet. Letter "A" was the original characteristic for all parts. This letter will be changed by DSCC when necessary.

1.2.1.2 Characteristic. The characteristic refers to the voltage-temperature limits of the capacitor. The first letter (B) identifies the rated temperature range of -55°C to +125°C. The second letter indicates the voltage-temperature limits as shown in table I.

Comments, suggestions, or questions on this document should be addressed to: Defense Supply Center, Columbus, DSCC-VAT, Post Office Box 3990, Columbus, OH 43218-3990 or e-mailed to [capacitorfilter@dla.mil](mailto:capacitorfilter@dla.mil). Since contact information can change, you may want to verify the currency of this address information using the ASSIST Online database at <http://assist.daps.dla.mil>.

MIL-PRF-123D  
W/AMENDMENT 1

TABLE I. Voltage-temperature limits.

Symbol	Capacitance change with reference to +25°C	
	Steps A through D of table XVIII	Steps E through G of table XVIII
G	90 ±20 ppm/°C	90 ±20 ppm/°C
P	0 ±30 ppm/°C	0 ±30 ppm/°C
R	+15, -15 percent	+15, -40 percent
X	+15, -15 percent	+15, -25 percent

1.2.1.3 Voltage. The rated voltage for continuous operation at +125°C is identified by a single letter as shown in table II.

TABLE II. Rated voltage.

Symbol	Rated voltage (Volts, dc)
A	25
B	50
C	100
D	200
E	500
K	150
L	300
M	400

1.2.1.4 Capacitance. The nominal capacitance value, expressed in picofarads (pF) is identified by a three digit number; the first two digits represent significant figures and the last digit specifies the number of zeros to follow. When the nominal value is less than 10 pF, the letter "R" is used to indicate the decimal point and the succeeding digit(s) of the group represent significant figure(s). 1R0 indicates 1.0 pF; R75 indicates .75 pF; and 0R5 indicates 0.5 pF.

1.2.1.5 Capacitance tolerance. The capacitance tolerance is identified by a single letter as shown in table III.

TABLE III. Capacitance tolerance.

Symbol	Capacitance tolerance ±
B	0.1 pF
C	0.25 pF
D	0.5 pF
F	1 percent
G	2 percent
J	5 percent
K	10 percent
M	20 percent

1.2.1.6 Termination. The termination is identified by a single letter as shown in [table IV](#). Nonleaded termination types W and Y are no longer available. Nonleaded termination W (100 percent tin or tin-lead alloy) and nonleaded termination Y (100 percent tin) were removed due to the possibility of tin whisker growth. Termination Z is a direct replacement. Termination S may also be suitable, but since solder coating increases the length, width, and height ([see 3.1](#)), the user should determine if capacitors will fit into their design. Leaded termination A (copper-iron-zinc (194 alloy)) is no longer available.

MIL-PRF-123D  
W/AMENDMENT 1

TABLE IV. Termination.

Leaded capacitors		Nonleaded capacitors <u>1/</u>	
Symbol	Termination type	Symbol	Termination type
C	Copper, solder coated, 60 microinches, minimum	G	Silver - nickel - gold
W	Copper clad steel, solder coated, 60 microinches, minimum	M	Palladium/silver alloy
		S	Guarded, solder coated <u>2/</u>
		Z	Base metallization-barrier-solder plated (tin/lead alloy with a minimum of 4 percent lead) <u>1/</u>

1/ Nonleaded terminations W and Y are no longer available. Termination Z is a direct replacement (see 1.2.1.6 and 6.5 for details).

2/ A guarded termination is one in which the interelectrode metallization is separated from the final finish by a barrier or guard metal; e.g., copper or nickel, etc.

## 2. APPLICABLE DOCUMENTS

2.1 General. The documents listed in this section are specified in sections 3 and 4 of this specification. This section does not include documents cited in other sections of this specification or recommended for additional information or as examples. While every effort has been made to ensure the completeness of this list, document users are cautioned that they must meet all specified requirements documents cited in sections 3 and 4 of this specification, whether or not they are listed.

### 2.2 Government documents.

2.2.1 Specifications, standards, and handbooks. The following specifications, standards, and handbooks form a part of this document to the extent specified herein. Unless otherwise specified, the issues of these documents are those cited in the solicitation or contract.

#### DEPARTMENT OF DEFENSE SPECIFICATION

(See supplement 1 for list of associated specification sheets.)

#### DEPARTMENT OF DEFENSE STANDARDS

[MIL-STD-202](#) - Test Methods for Electronic and Electrical Component Parts.

[MIL-STD-790](#) - Standard Practice for Established Reliability and High Reliability Qualified Products List (QPL) Systems for Electrical, Electronic, and Fiber Optic Parts Specifications.

[MIL-STD-1276](#) - Leads for Electronic Component Parts.

(Copies of these documents are available online at <http://assist.daps.dla.mil/quicksearch/> or from the Standardization Document Order Desk, 700 Robbins Avenue, Building 4D, Philadelphia, PA 19111-5094.)

2.2.2 Non-Government publications. The following documents form a part of this document to the extent specified herein. Unless otherwise specified, the issues of these documents are those cited in the solicitation or contract.

#### ELECTRONIC INDUSTRIES ALLIANCE (EIA)

[EIA-469](#) - Standard Test Method for Destructive Physical Analysis (DPA) of Ceramic Monolithic Capacitors.

MIL-PRF-123D  
W/AMENDMENT 1

EIA-483 - Standard Method of Test for Effective Series Resistance (ESR) and Capacitance of Multilayer Ceramic Capacitors at High Frequencies.

(Copies of these documents are available from <http://global.ihs.com/> or Global Engineering Documents, Attn: Customer Service Department, 15 Inverness Way East, Englewood CO 80112-5776.)

2.3 Order of precedence. In the event of a conflict between the text of this document and the references cited herein (except for related associated specifications, specification sheets, or MS sheets), the text of this document takes precedence. Nothing in this document, however, supersedes applicable laws and regulations unless a specific exemption has been obtained.

### 3. REQUIREMENTS

3.1 Specification sheets. The individual item requirements shall be as specified herein and in accordance with the applicable specification sheet. In the event of any conflict between requirements of this specification and the specification sheet, the latter shall govern.

3.2 Qualification. Capacitors furnished under this specification shall be products that are authorized by the qualifying activity for listing on the applicable qualified products list at the time of award of contract (see 4.4 and 6.3).

3.2.1 Category A distributors. Category A distributors may be used under the following conditions:

- a. The distributor shall be an authorized distributor of the manufacturer in accordance with MIL-STD-790.
- b. The distributor shall not open the level of packaging containing the unit containers. This level of packaging shall bear a stamp stating "Not to be opened by the distributor." The distributor shall not remark or retest the product.
- c. MIL-PRF-123 product shall be handled as a nonstocking item only.
- d. The distributor shall be held accountable by the manufacturer to supply the complete data package to the user with each order.
- e. The manufacturer shall be responsible for auditing the distributors to the requirements of MIL-STD-790 and the limitations and controls as stated herein.

3.3 Qualified Product List (QPL) system. The manufacturer shall establish and maintain a QPL system for capacitors covered by this specification. This QPL system shall be established and maintained in accordance with the procedures and requirements specified in MIL-STD-790 and herein.

3.4 Interface and physical dimensions. Capacitors shall meet the interface and physical dimensions specified (see 3.1).

3.4.1 Dielectric parameters. Capacitors supplied to this specification shall have a minimum dielectric thickness of 0.8 mil for 50 volt rated capacitors or 1 mil for capacitors with ratings above 50 volts. Dielectric thickness is the actual measured thickness of the fired ceramic dielectric layer. Voids, or the cumulative effect of voids, shall not reduce the total dielectric thickness by more than 50 percent (see figure 1). Maximum dielectric constant shall be 3000.

3.4.2 Electrode parameters. Nickel electrodes shall not be used in capacitors supplied to this specification.

3.4.3 Lead attachment (leaded capacitors only) (see 3.1). Capacitors with leads shall have the leads attached to the ceramic chip body using high temperature solder with a minimum liquidus point of +260°C.

3.4.4 Lead wire. Lead wire shall be in accordance with MIL-STD-1276 (see 3.1).

MIL-PRF-123D  
W/AMENDMENT 1

3.4.5 Pure tin. The use of pure tin, as an underplate or final finish, is prohibited both internally and externally. Tin content of capacitor components and solder shall not exceed 96 percent, by mass. Tin shall be alloyed with a minimum of 4 percent lead, by mass (see 6.5).

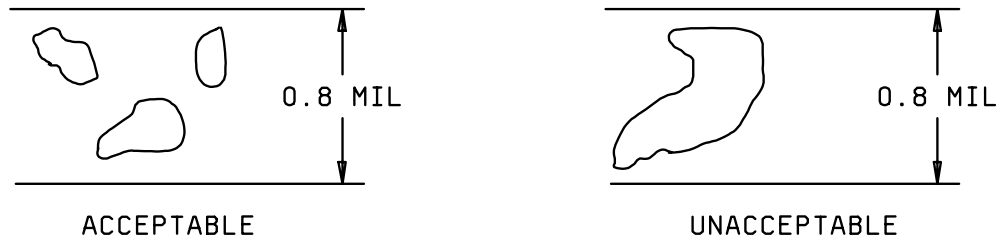

FIGURE 1. Dielectric parameters.

3.5 Nondestructive internal examination. Prior to termination, all capacitors shall be subjected to ultrasonic examination or some other method of nondestructive internal examination approved by the qualifying activity. The method of examination shall be determined by the manufacturer. When capacitors are examined as specified in 4.6.1, there shall be no devices delivered that show unacceptable responses as defined in EIA-469.

3.6 Pre-termination destructive physical analysis. When examined as specified in 4.6.2, capacitors shall meet the requirements of EIA-469.

3.7 Visual examination.

3.7.1 Pre-encapsulation visual inspection (lead capacitors only). When lead capacitors are examined as specified in 4.6.3, they shall meet the visual inspection requirements specified in appendix A.

3.7.2 Visual examination of nonlead capacitors. When examined as specified in 4.6.3, capacitors shall meet the visual requirements specified in appendix B.

3.8 Preencapsulation terminal strength (lead capacitors only). Capacitors shall be tested as specified in 4.6.4 and appendix C. The force shall be applied in the manner specified. In no case shall the termination rupture at a load less than that specified in table XV.

3.9 Radiographic inspection (encapsulated capacitors only). When radiographed in accordance with 4.6.5, lead capacitors shall meet the following requirements (see appendix D):

- a. There shall be no evidence of improperly made connections, substandard soldering, structural weakness, or solder bridging that reduces the distance between terminals to less than 50 percent.
- b. The interface between each lead and capacitor element shall have solder for at least 80 percent of the interface dimension (see figure D-3).
- c. The encapsulation material shall have a minimum thickness of .005 inch (0.13 mm) (dimension T, figure D-3), on all external surfaces of the chip and any protrusions of termination, solder, or lead frame, with the exception of the lead side of the radial lead capacitors, which shall have a minimum thickness of .010 inch (0.25 mm) (dimension T<sub>R</sub>, figure D-3).
- d. If a lead has a portion which has been flattened to accommodate the ceramic element more easily, the formed portion of the lead shall be completely inside the encapsulation material. Any unintentional nick or deformation of the leads shall not reduce the lead diameter below 90 percent of the minimum diameter required (see 3.1).

MIL-PRF-123D  
W/AMENDMENT 1

- e. Extraneous particles, such as solder spikes or solder balls, shall not exceed .015 inch (0.38 mm) in any dimension, nor shall the total encapsulation thickness be reduced to less than the thickness  $T$  or  $T_R$  as defined in 3.9.c. Total encapsulation thickness is the combined measurement of the encapsulation thickness on either side of the particle.

3.10 Thermal shock and voltage conditioning. When tested as specified in 4.6.6, capacitors shall withstand the extremes of high and low temperature without visible damage and meet the following requirements with the percent defective allowed as shown in [table XVI](#):

- a. Dielectric withstanding voltage (at +25°C): As specified in 3.13.
- b. Insulation resistance (at +25°C): Shall be not less than the initial requirement.
- c. Insulation resistance (at elevated ambient temperature): Shall be not less than the initial requirement (see 3.14).
- d. Dissipation factor (at +25°C): Shall not exceed the value specified (see 3.12).
- e. Capacitance (at +25°C): Shall be within the tolerance specified ([see 3.1](#)).

Capacitance values of not more than 5 percent or .5 pF, whichever is greater, for BX and BR characteristics or of no more than 1 percent or .3 pF, whichever is greater, for BP and BG characteristics beyond specified tolerance limit shall be removed from the lot but shall not be considered defective for determination of the percent defective allowed.

3.11 Capacitance. When measured as specified in 4.6.7, the capacitance shall be within the specified tolerance ([see 3.1](#)).

3.12 Dissipation factor (DF). When determined as specified in 4.6.8, the dissipation factor shall not exceed 2.5 percent for BX and BR characteristics, 0.15 percent for BP characteristic, and 0.05 percent for BG characteristic, unless otherwise specified ([see 3.1](#)). For capacitors of less than 10 pF (chips) and 30 pF (leaded devices), the dissipation factor shall not exceed 0.25 percent for BP and 0.15 percent for BG. (A negative reading is not considered a failure.)

3.13 Dielectric withstanding voltage (DWV). Capacitors shall withstand the direct current (dc) potential specified in 4.6.9 without damage or breakdown.

3.14 Insulation resistance (IR). When measured as specified in 4.6.10, the insulation resistance shall be not less than the value specified:

- a. At +25°C: 100,000 megohms or 1,000 megohm-microfarads, whichever is less.
- b. At +125°C: 10,000 megohms or 100 megohm-microfarads, whichever is less.

3.15 Destructive physical analysis. When examined as specified in 4.6.11, capacitors shall meet the requirements specified herein.

3.16 Terminal strength. When capacitors are tested as specified in 4.6.12, there shall be no loosening or rupturing of the terminals.

3.17 Solderability.

3.17.1 Solderability (leaded capacitors). When leaded capacitors are tested as specified in 4.6.13.1, the dipped surface of the leads shall be at least 90 percent covered with a new, smooth, solder coating. The remaining 10 percent may contain only small pinholes or rough spots; these shall not be concentrated in one area. Bare base metal where the solder dip failed to cover the original coating is an indication of poor solderability, and shall be cause for failure. In case of dispute, the percent of coverage with pinholes or rough spots shall be determined by actual measurement of these areas, as compared to the total area.

MIL-PRF-123D  
W/AMENDMENT 1

3.17.2 Solderability (nonleaded capacitors). When nonleaded capacitors are tested as specified in 4.6.13.2, the immersed metallized surface shall be at least 85 percent covered with a smooth solder coating. The remaining 15 percent of the surface may contain small pinholes or exposed termination material; however, these shall not be concentrated in one area.

3.18 Resistance to soldering heat.

3.18.1 Resistance to soldering heat (leaded capacitors). When tested as specified in 4.6.14.1, capacitors shall meet the following requirements:

- a. Insulation resistance at +25°C: Not less than the initial +25°C requirement (see 3.14).
- b. Capacitance change:
  - (1) BR and BX characteristics: Shall change not more than -1.0 percent to +6.0 percent from the initial measured value.
  - (2) BG and BP characteristics: Shall change not more than -1.0 percent to +2.0 percent or 0.5 pF, whichever is greater, from the initial measured value.
- c. Dissipation factor: Shall not exceed the initial limits (see 3.12).

3.18.2 Resistance to soldering heat (nonleaded capacitors). When tested as specified in 4.6.14.2, capacitors shall meet the following requirements:

- a. Visual examination: There shall be no evidence of mechanical damage or declamation or exposed electrodes. Leaching shall be a maximum of 25 percent on each edge of mounting area (see figure 2).
- b. Insulation resistance, capacitance change, and dissipation factor shall be measured as specified in 3.18.1.

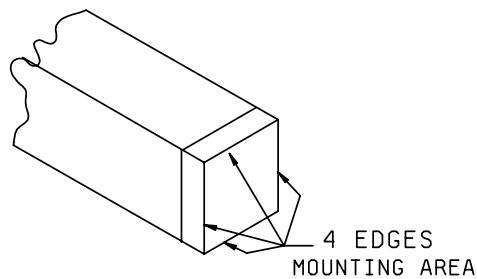

FIGURE 2. Mounting area.

3.19 Voltage-temperature limits. The capacitance change over the range of temperatures specified in 4.6.15 shall not exceed the limits specified in table V. The capacitance value obtained in step C of table XVIII shall be considered as the reference point. For BP and BG values below 20 pF, see table VI.

3.20 Moisture resistance. When tested as specified in 4.6.16, capacitors shall meet the following requirements:

- a. Visual examination: No mechanical damage. Marking shall remain legible.
- b. Dielectric withstanding voltage (moisture resistance, normal voltage only): As specified in 3.13.

MIL-PRF-123D  
W/AMENDMENT 1

- c. Insulation resistance: Humidity, steady state,  $1.3 \pm 0.25$  volts - Shall meet the initial +25°C requirement specified in 3.14. Moisture resistance, normal voltage - not less than 50 percent of the initial +25°C requirement specified in 3.14.
- d. Capacitance: Change not to exceed  $\pm 10$  percent from initial measured value for BX and BR characteristics, and not more than  $\pm 3$  percent or .3 pF, whichever is greater, for BP and BG characteristics.

TABLE V. Capacitance change with reference to +25°C.

Characteristic	Steps A through D of table XVIII Bias = 0 volt	Steps E through G of table XVIII Bias = rated voltage
BR	$\pm 15$ percent	+15, -40 percent
BX	$\pm 15$ percent	+15, -25 percent
BP <u>1/</u>	$0 \pm 30$ ppm/°C	$0 \pm 30$ ppm/°C
BG <u>1/</u>	$90 \pm 20$ ppm/°C	$90 \pm 20$ ppm/°C

1/ At the +25°C stability point, the capacitance measurement may be  $\pm .2$  percent or -0.05 pF, whichever is greater, from the +25°C reference.

TABLE VI. Temperature coefficient tolerances for characteristics BP and BG values below 20 pF.

Permissible capacitance change from capacitance at +25°C in ppm/°C					
Temperature	Less than 2.1 pF	2.15 pF to 4.2 pF	4.3 pF to 8.0 pF	8.1 pF to 18 pF	Greater than 18 pF
+125°C	<u>1/</u>	$\pm 250$ ppm/°C	$\pm 120$ ppm/°C	$\pm 60$ ppm/°C	$\pm 30$ ppm/°C
-55°C <u>2/</u>	<u>1/</u>	+246.25 -326.25	+116.25 -166.25	+55.00 -91.25	+27.50 -53.75

1/ Not practically measurable.

2/ The ppm/°C values for -55°C were calculated by dividing ppm by -80°C.

3.21 Vibration, high frequency (leaded capacitors only). When capacitors are tested as specified in 4.6.17, there shall be no intermittent contacts of 0.5 millisecond (ms) or greater duration, open or short circuitry, or evidence of mechanical damage.

3.22 Resistance to solvents. When capacitors are tested as specified in 4.6.18, there shall be no evidence of mechanical damage and the marking shall remain legible.

3.23 Life (at elevated ambient temperature). When tested as specified in 4.6.19, capacitors shall meet the following requirements:

a. 250-hour limits:

- (1) Insulation resistance (at +125°C): Shall not be less than 50 percent of the value specified (see 3.14).
- (2) Visual examination: No mechanical damage. Marking shall remain legible.
- (3) Insulation resistance (at +25°C): Shall not be less than 50 percent of the value specified (see 3.14).

MIL-PRF-123D  
W/AMENDMENT 1

- (4) Capacitance: Change not to exceed  $\pm 15$  percent from the initial measured value for BX and BR characteristics, and  $\pm 0.3$  percent or 0.3 pF, whichever is greater, from the initial measured value for BP and BG characteristics.
  - (5) Dissipation factor: Shall not exceed the value specified (see 3.12).
- b. 1,000-hour, 2,000-hour, and 4,000-hour limits:
- (1) Insulation resistance (at +125°C): Shall not be less than 30 percent of the value specified (see 3.14).
  - (2) Visual examination: No mechanical damage. Marking shall remain legible.
  - (3) Insulation resistance (at +25°C): Shall not be less than 30 percent of the value specified (see 3.14).
  - (4) Capacitance: Change not to exceed  $\pm 20$  percent from the initial measured value for BX and BR characteristics, and  $\pm 0.5$  percent or 0.5 pF, whichever is greater, from the initial measured value for BP and BG characteristics.
  - (5) Dissipation factor: Shall not exceed 3.0 percent for BX and BR characteristics, and 0.15 percent for BP and BG characteristics.

3.24 Marking capacitors. Capacitors shall be marked as specified herein. Paper labels shall not be used. Other markings which in any way interfere with, obscure, or confuse those specified herein, are prohibited. Each capacitor shall be legibly marked and will withstand the environmental conditions specified herein. The marking shall be a minimum resistance of  $1 \times 10^9$  ohms per square and shall remain legible after coating the parts with 1.5 to 3 mils of transparent conformal coating such as polyurethane, acrylic, or the equivalent.

3.24.1 JAN and J marking. The United States Government has adopted, and is exercising legitimate control, over the certification marks "JAN" and "J" respectively, to indicate that items so marked or identified are manufactured to, and meet all the requirements of specifications. Accordingly, items acquired to and meeting all of the criteria specified herein and in applicable specification, shall bear the certification mark "JAN" except that items too small to bear the certification mark "JAN" shall bear the letter "J". The "JAN" or "J" shall be placed immediately before the PIN except that if such location would place a hardship on the manufacturer in connection with such marking, the "JAN" or "J" may be located on the first line above or below the PIN. Items furnished under contracts or orders which either permit or require deviation from the conditions or requirements specified herein and in applicable specifications shall not bear "JAN" or "J". In the event an item fails to meet the requirements of this specification and the applicable specification sheets or associated specifications, the manufacturer shall remove completely the military PIN and the "JAN" or the "J" from the sample tested and also from all items represented by the sample. The "JAN" or "J" certification mark shall not be used on products acquired to contractor drawings or specifications. The United States Government has obtained Certificate of Registration Number 504,860 for the certification mark "JAN" and Registration Number 1,586,261 for the certification mark "J".

3.24.2 Full marking (leaded capacitors). Unless otherwise specified (see 3.11), capacitors shall be marked with the "JAN" or "J" marking, part number, date and lot code, manufacturer's five digit commercial and government entity (CAGE) code, voltage, capacitance, and capacitance tolerance. There shall be no space between the symbols that comprise the part number. The date code and lot number shall consist of the year, week, and lot code. For example: Week 40 of 2005 would be 0540-. Capacitors shall be marked in accordance with one of the examples shown on figure 3 (see 3.1).

MIL-PRF-123D  
W/AMENDMENT 1

3.24.3 Marking (chip capacitors). Capacitors shall be legibly marked in a contrasting color in accordance with either of the two options. (NOTE: Packaging containers shall be marked with the PIN, capacitance, capacitance tolerance, voltage, "JAN" brand, lot date code, and the CAGE code.) Other markings which in any way interfere with, obscure, or confuse those specified herein are prohibited.

- a. Option A: In accordance with [table VII](#).
- b. Option B: In accordance with [table VIII](#) using a two character system. The first character shall be an alphabetic symbol and shall designate the first and second significant figures. The second character shall be a numerical digit and shall designate the decimal multiplier of capacitance in pF (e.g., A1 =  $1 \times 10^1 = 10$  pF, J5 =  $2.2 \times 10^5 = 0.22 \times 10^6 = 0.22$   $\mu$ F). The marking shall appear in black or legible contrast. The size and orientation of the marking shall be the option of the manufacturer. At the option of the manufacturer, the capacitor may be laser marked with the manufacturer's trademark or symbol and the capacitance code in accordance with [table VIII](#).

Additional marking may appear provided that it does not interfere with the required marking.

3.25 Workmanship. Capacitors shall be processed in such a manner as to be uniform in quality when using 10X magnification. External leads shall not exhibit cuts, nicks or scrapes exceeding 10 percent of the diameter for round and flat lead wire parts, except as follows:

- a. Round leads: Within .050 inch of the body of the component, 10 percent of the surface area of the leads may exhibit bare base metal. These capacitors are not expected to be solderable within .050 inch of the case.
- b. Flat leads (styles CKS22, CKS23, and CKS24): Surface of lead may exhibit bare base metal on edges except on installation portion of lead. These capacitor leads are not expected to be solderable above the plane of the body mounting base.

3.26 Supplying to looser capacitance tolerance and lower rated voltage. Parts qualified and marked to tighter capacitance tolerance or higher rated voltage, with procuring agency approval, are substitutable for parts marked to looser capacitance tolerance or lower rated voltage, provided all other values, such as case size, characteristic, and leads are the same. The substitutable parts shall not be remarked unless specified in the contract or purchase order ([see 6.2](#)), the lot date codes on the parts are unchanged, and the workmanship criteria is met.

3.27 Recycled, recovered, or environmentally preferable materials. Recycled, recovered, or environmentally preferable materials should be used to the maximum extent possible provided that the material meets or exceeds the operational and maintenance requirements, and promotes economically advantageous life cycle costs.

MIL-PRF-123D  
W/AMENDMENT 1

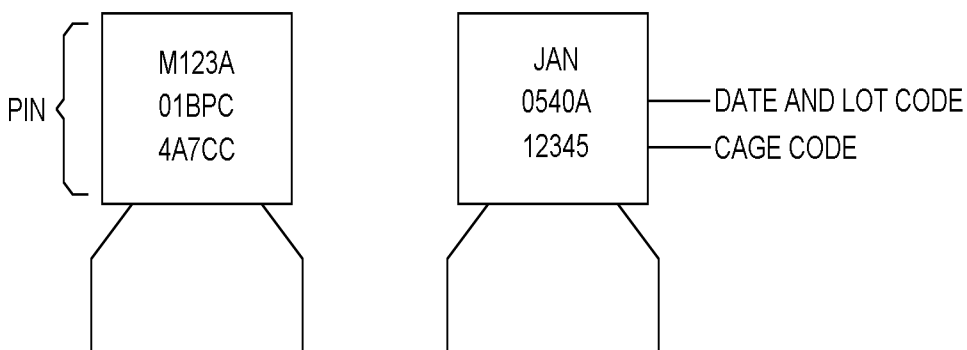

EXAMPLE 1

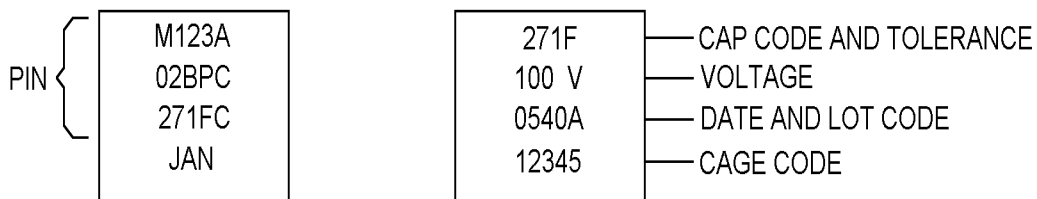

EXAMPLE 2

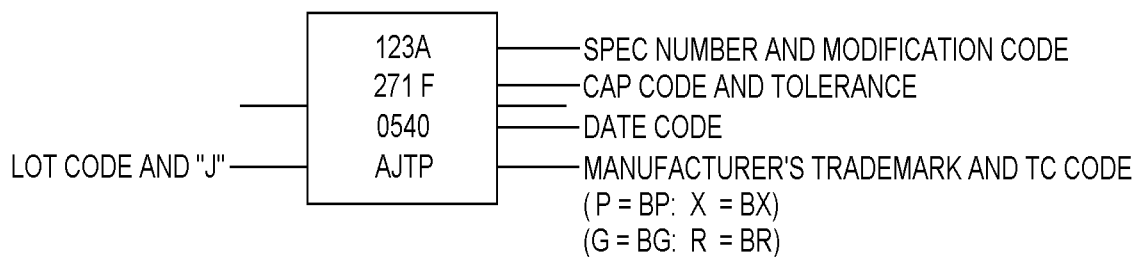

EXAMPLE 3

FIGURE 3. Marking examples for leaded capacitors.

MIL-PRF-123D  
W/AMENDMENT 1

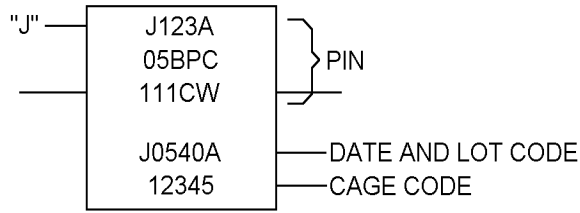

EXAMPLE 4

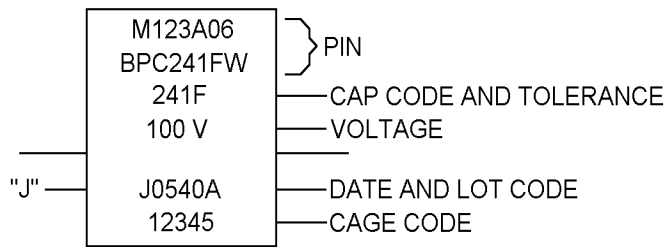

EXAMPLE 5

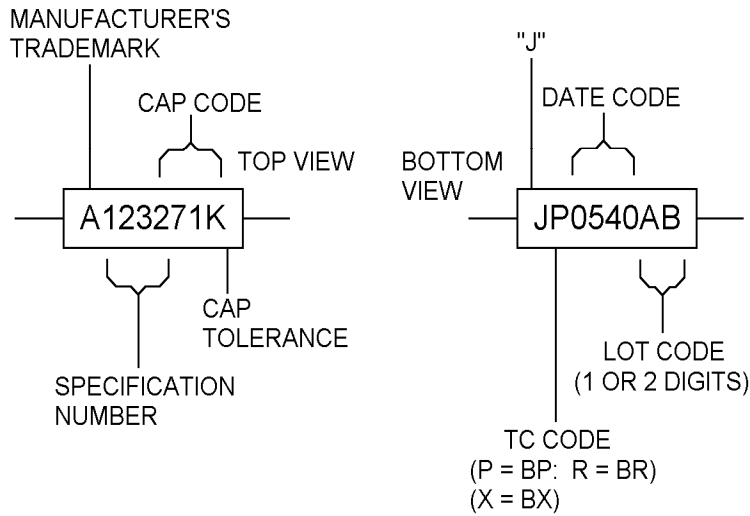

EXAMPLE 6

FIGURE 3. Marking examples for leaded capacitors - Continued.

MIL-PRF-123D  
W/AMENDMENT 1

4. VERIFICATION

4.1 Classification of inspections. The inspections specified herein are classified as follows:

- a. Qualification inspection (see 4.4).
- b. In-process inspection (see 4.5.1).
- c. Quality conformance inspection (see 4.5.2 and 4.5.3).

4.2 QPL system. The manufacturer shall establish and maintain a QPL system in accordance with 3.3. Evidence of such compliance is a prerequisite for qualification and retention of qualification.

4.2.1 Purchased raw materials. The following documentation for purchased raw materials shall be retained:

- a. Procurement documentation: Traceability.
- b. Physical and chemical property data.
- c. Performance evaluation/characterization data.

4.2.2 In-house prepared materials. The following documentation for in-house prepared materials shall be retained:

- a. Fabrication process control data.
- b. Physical and chemical property data.
- c. Performance evaluation/characterization data.

4.2.3 Manufacturing lot performance information. Lot performance information relating to material, process, lot conformance, inspections, and product shall be retained by the manufacturer for 10 years from the date of the manufacture of the parts.

4.3 Inspection conditions and reference measurements.

4.3.1 Conditions. Unless otherwise specified herein, all inspections shall be performed in accordance with the test conditions specified in the "GENERAL REQUIREMENTS" of MIL-STD-202, except relative humidity shall not exceed 75 percent. Accuracy of all test voltage measurements shall be within  $\pm 2.0$  percent of the specified voltage. All test temperatures above 25°C shall have a tolerance of +4°C, -0°C unless otherwise specified herein.

4.3.2 Reference measurements. When requirements are based on comparative measurements made before and after conditioning, the reference measurement shall be considered the last measurement made at +25°C  $\pm 3$ °C prior to conditioning. Unless reference measurements have been made within 30 days prior to the beginning of conditioning, they shall be repeated.

4.3.3 Power supply. The power supply used for life testing shall have a regulation of  $\pm 2$  percent or less of the specified test voltage.

MIL-PRF-123D  
W/AMENDMENT 1

TABLE VII. Marking for small nonleaded capacitors.

Character	Significant units	Capacitance (pF) and multiplier					
		Orange (x 0.1)	Black (x 1.0)	Green (x 10)	Blue (x 100)	Violet (x 1000)	Red (x 10,000)
A	10	1.0	10	100	1000	10,000	100,000
B	11	1.1	11	110	1100	11,000	110,000
C	12	1.2	12	120	1200	12,000	120,000
D	13	1.3	13	130	1300	13,000	130,000
E	15	1.5	15	150	1500	15,000	150,000
H	16	1.6	16	160	1600	16,000	160,000
I	18	1.8	18	180	1800	18,000	180,000
J	20	2.0	20	200	2000	20,000	200,000
K	22	2.2	22	220	2200	22,000	220,000
L	24	2.4	24	240	2400	24,000	240,000
N	27	2.7	27	270	2700	27,000	270,000
O	30	3.0	30	300	3000	30,000	300,000
R	33	3.3	33	330	3300	33,000	330,000
S	36	3.6	36	360	3600	36,000	360,000
T	39	3.9	39	390	3900	39,000	390,000
V	43	4.3	43	430	4300	43,000	430,000
W	47	4.7	47	470	4700	47,000	470,000
X	51	5.1	51	510	5100	51,000	510,000
Y	56	5.6	56	560	5600	56,000	560,000
Z	62	6.2	62	620	6200	62,000	620,000
3	68	6.8	68	680	6800	68,000	680,000
4	75	7.5	75	750	7500	75,000	750,000
7	82	8.2	82	820	8200	82,000	820,000
9	91	9.1	91	910	9100	91,000	910,000

TABLE VIII Optional marking for chip capacitors.

First character				Second character	
Alphabetic character	Significant figures	Alphabetic character	Significant figures	Numerical character	Decimal multiplier
A	1.0	T	5.1	0	10 <sup>0</sup>
B	1.1	U	5.6	1	10 <sup>1</sup>
C	1.2	V	6.2	2	10 <sup>2</sup>
D	1.3	W	6.8	3	10 <sup>3</sup>
E	1.5	X	7.5	4	10 <sup>4</sup>
F	1.6	Y	8.2	5	10 <sup>5</sup>
G	1.8	Z	9.1	6	10 <sup>6</sup>
H	2.0	a	2.5	7	10 <sup>7</sup>
J	2.2	b	3.5	8	10 <sup>8</sup>
K	2.4	d	4.0	9	10 <sup>9</sup>
L	2.7	e	4.5		
M	3.0	f	5.0		
N	3.3	m	6.0		
P	3.6	n	7.0		
Q	3.9	t	8.0		
R	4.3	y	9.0		
S	4.7				

MIL-PRF-123D  
W/AMENDMENT 1

4.4 Qualification inspection. Qualification inspection shall be performed at a laboratory acceptable to the qualifying agency (see 6.3) on sample units produced with equipment and procedures normally used in production.

4.4.1 Sample size. The number of capacitors to be specified for qualification inspection shall be as specified in table IX and in appendix E of this specification. Each capacitor style shall be qualified separately.

4.4.2 Test routine. Sample units shall be subjected to the qualification inspection specified in table IX in the order shown. Sample units shall have been subjected to the in-process screening required by this specification and all sample units shall be subjected to the inspection of group I. The sample shall then be divided as specified in table IX as applicable.

4.4.3 Failures. Failures in excess of those allowed in table IX shall be cause for refusal to grant qualification approval.

TABLE IX. Qualification inspection.

Inspection	Requirement paragraph	Test method paragraph	Number of sample units to be inspected	Number of failures <sup>1/</sup>
<u>Group I</u>				
Radiographic inspection (leaded devices only)	3.9	4.6.5	All	N/A
Thermal shock and voltage conditioning	3.10	4.6.6	186 min <sup>2/</sup>	See table XVI
Dielectric withstanding voltage	3.13	4.6.9		
Insulation resistance +25°C	3.14	4.6.10		
Insulation resistance +125°C	3.14	4.6.10		
Capacitance	3.11	4.6.7		
Dissipation factor	3.12	4.6.8		
<u>Group II</u>				
Visual and mechanical examination; material, design, construction and workmanship	3.1, 3.4, 3.24 and 3.25	4.6.3	15	1
Destructive physical analysis <sup>3/</sup>	3.15	4.6.11		
<u>Group IIIa - Leaded devices</u>				
Terminal strength	3.16	4.6.12.1	12	1
Solderability	3.17.1	4.6.13.1		
Resistance to soldering heat	3.18.1	4.6.14.1		
<u>Group IIIb - Nonleaded devices</u>				
Terminal strength	3.16	4.6.12.2	12	1
Solderability	3.17.2	4.6.13.2		
Resistance to soldering heat	3.18.2	4.6.14.2		
<u>Group IV</u> <sup>4/</sup>				
Voltage-temperature limits	3.19	4.6.15	12	1
Moisture resistance	3.20	4.6.16.2		
<u>Group V</u>				
Humidity, steady state, low voltage	3.20	4.6.16.1	12	0
Vibration, high frequency (leaded capacitors only)	3.21	4.6.17		1
Resistance to solvents	3.22	4.6.18		
<u>Group VI</u>				
Life	3.23	4.6.19	123	1

<sup>1/</sup> A sample unit having one or more defects will be charged as a single defective.

<sup>2/</sup> Additional samples over the 186 minimum should be included, based on table XVI to allow for the percent defective allowable. Twelve additional samples shall be required for nonleaded devices.

<sup>3/</sup> DPA samples shall be divided with 10 samples subjected to group 1 (see 4.6.11.1) and 5 samples to group 2 (see 4.6.11.2).

<sup>4/</sup> Leads may be soldered to chip capacitor to facilitate the tests required in group IV.

MIL-PRF-123D  
W/AMENDMENT 1

4.4.4 Verification of qualification. Every 12 months, the manufacturer shall provide verification of qualification to the qualifying activity. Continuation of qualification shall be based on meeting the following requirements:

- a. MIL-STD-790 program.
- b. Product design has not been modified.
- c. Certification that the manufacturer still maintains the capabilities and facilities necessary to produce these items.
- d. Verification of the results of group A, group B, and group C inspections including identification of failed lots and subgroups and failure modes.

4.5 In-process inspection and quality conformance inspection.

4.5.1 In-process inspection. Each production lot of parts shall be inspected in accordance with table X. The nondestructive internal examination used (if other than ultrasonic examination) shall be approved by the qualifying activity. Other screening examinations may be applied at the option of the manufacturer, as approved by the qualifying activity.

4.5.1.1 Rework. Rework is not allowed on any operations including and subsequent to the formation of the slurry, except for marking and lead rework.

TABLE X. In-process inspection.

Inspection	Requirement paragraph	Test method paragraph	Sample size
Nondestructive internal examination	3.5	4.6.1	100 percent
Pre-termination destructive physical analysis	3.6	4.6.2	Table XIV
Visual examination	3.7	4.6.3	100 percent
Pre-encapsulation terminal strength (leaded capacitors only)	3.8	4.6.4	Table XV
Post termination, unencapsulated destructive physical analysis	3.15	4.6.11	Table XVII, group I

4.5.2 Inspection of product for delivery. Inspection of product for delivery shall consist of groups A and B inspection.

4.5.2.1 Inspection lot. An inspection/production lot shall consist of all capacitors of a single nominal capacitance/voltage rating of one design, from the same dielectric material batch, and processed as a single lot through all manufacturing steps on the same equipment. The lot may contain all available capacitance tolerances for the nominal capacitance value. In addition, the lot shall conform to the following:

- a. Raw materials, such as end terminations, solder, ceramic raw material, binders, and electrode ink, shall be traceable to the same lot or batch and be from the same contractor.
- b. A lot number shall be assigned before electrode printing (inking) and be manufactured from the same slurry and cast on the same belt or comparable equipment (see 3.4).
- c. A single mix of a basic ceramic formulation fired through one kiln with one temperature profile during the process, with constant dielectric design, with, in general, no more than 20 percent variation in the number of active dielectrics being assembled in one continuous buildup. Sublots may be allowed to provide a spread in capacitance value to improve the yield. This will normally be done in the case of tight tolerances and low capacitance. In some cases, more than 20 percent variation in the number of active dielectrics may be required in these circumstances (see 3.3).

MIL-PRF-123D  
W/AMENDMENT 1

- d. End termination material shall be consistent in formulation and traceable to a single batch and shall be fired in the same kiln with one temperature profile during the process. All parts shall enter the kiln in one continuous operation/run for end termination firing.
- e. Lot identity shall be maintained from the time the lot is assembled to the time it is accepted.
- f. The lot date code shall be assigned prior to lead attachment for leaded devices and prior to final end termination for nonleaded devices.

4.5.2.2 Group A inspection. Group A inspection shall consist of the tests and examinations specified in table XI. The following details shall apply:

- a. Failure to meet destructive physical analysis (DPA) limits shall cause the lot to be rejected.
- b. A summary of the results of group A inspection on each lot that meets requirements shall be submitted to the purchaser with the parts.
- c. A copy of the applicable DPA report shall be submitted to the purchaser with each lot of parts.

TABLE XI. Group A inspection.

Inspection	Requirement paragraph	Test method paragraph	Sampling procedure
<u>Subgroup 1</u> Thermal shock and voltage conditioning <u>1/</u> <u>2/</u>	3.10	4.6.6.1 and 4.6.6.2	100% inspection (see table XVI)
Voltage conditioning at +85°C <u>2/</u> <u>3/</u>	3.10	4.6.6.3	100% inspection (see table XVI, PDA overall requirement only)
Radiographic inspection (encapsulated capacitors only)	3.9	4.6.5	100 % inspection
<u>Subgroup 2</u> Visual and mechanical inspection; material, physical dimensions, design, construction, marking, and workmanship	3.1, 3.4, 3.24, and 3.25	4.6.3	20 samples 0 failures
<u>Subgroup 3</u> Destructive physical analysis	3.15	4.6.11	See table XVII

- 1/ For solder coated nonleaded capacitor chips, thermal shock and voltage conditioning in accordance with 4.6.6.1 and 4.6.6.2 may be performed prior to addition of final metallization; and if performed, shall not be required during group A.
- 2/ The DWV post test is not applicable if optional voltage conditioning was performed at 250 percent or more of the rated voltage.
- 3/ Voltage conditioning at +85°C is only required for solder coated nonleaded capacitor chips that had voltage conditioning performed prior to final metallization.

4.5.2.3 Group B inspection. Group B inspection shall consist of the tests specified in table XII and shall be performed on sample units from lots that have been subjected to and have passed group A inspection. Copies of group B data shall be forwarded to purchaser with parts. Parts may not be shipped until the conclusion of 1,000 hours of life test.

MIL-PRF-123D  
W/AMENDMENT 1

TABLE XII. Group B inspection.

Inspection	Requirement paragraph	Test method paragraph	Sample size	Accept / reject
<u>Subgroup 1</u> Thermal shock Life test	3.10 3.23	4.6.6.1 4.6.19	Table XIX	Table XIX
<u>Subgroup 2</u> Humidity, steady-state, low voltage	3.20	4.6.16.1	12	0
<u>Subgroup 3</u> Voltage-temperature limits Moisture resistance	3.19 3.20	4.6.15 4.6.16.2	12	1

4.5.3 Periodic inspection. Periodic inspection shall consist of group C inspection. Delivery of products that have passed group A and group B inspections shall not be delayed pending the results of periodic inspection.

4.5.3.1 Group C inspection. Group C inspection shall consist of the tests specified in table XIII in order shown. Samples shall be selected from lots that have passed group A and have been submitted for group B inspection. Separate samples of nonleaded, dual-in-line package, axial, and radial leaded capacitors shall be selected every 2 months in accordance with table XIII.

4.5.3.2 Disposition of sample units. Sample units that have been subjected to groups B and C inspections shall not be delivered on the contract. These samples shall be maintained by the manufacturer for a minimum of 10 years.

4.5.3.3 Noncompliance. If a sample fails to pass group C inspection, the manufacturer shall notify the qualifying activity and the cognizant inspection activity of such failure and take corrective action on the materials or processes, or both, as warranted, and on all units of product which can be corrected and which were manufactured under essentially the same conditions, with essentially the same materials and processes, and which are considered subject to the same failure. Acceptance and shipment of the product shall be discontinued until corrective action, acceptable to the Government, has been taken. After the corrective action has been taken, group C inspection shall be repeated on additional sample units (all inspection) or the inspection which the original sample failed, at the option of the qualifying activity. Group A (and group B if applicable) inspection may be reinstated; however, final acceptance shall be withheld until the group C inspection has shown that corrective action was successful. In the event of failure after reinspection, information concerning the failure and corrective action taken shall be furnished to the cognizant inspection activity and the qualifying activity.

TABLE XIII. Group C inspection.

Inspection	Requirement paragraph	Test method paragraph	Number of units to be inspected	Number of defectives permitted
<u>Subgroup 1 (leaded devices)</u>				
Subgroup 1a: Terminal strength	3.16	4.6.12.1	6	1
Subgroup 1b: Solderability	3.17.1	4.6.13.1	6	
Subgroup 1c: Resistance to soldering heat Resistance to solvents	3.18.1 3.22	4.6.14.1 4.6.18	6	
<u>Subgroup 2 (chip devices)</u>				
Subgroup 2a: Terminal strength	3.16	4.6.12.2	6	1
Subgroup 2b: Solderability	3.17.2	4.6.13.2	6	
Subgroup 2c: Resistance to soldering heat	3.18.2	4.6.14.2	6	

MIL-PRF-123D  
W/AMENDMENT 1

4.6 Methods of inspection.

4.6.1 Nondestructive internal examination (see 3.5). Capacitors shall be subjected to ultrasonic examination or some other method of nondestructive internal examination approved by the qualifying activity that allows the capacitors to meet the requirements of [EIA-469](#). The following details shall also be followed:

- a. The ultrasonic test equipment shall be cleaned and maintained in accordance with the test equipment manufacturer's instructions.
- b. The test facility shall establish a setup and operating procedure in accordance with the applicable test equipment manufacturer's instructions. Testing shall be done in accordance with the test equipment manufacturer's instructions and the test facility's operating procedures.
- c. Each facility shall have a responsible person who has successfully completed a nondestructive testing course for the ultrasonic test equipment. The ultrasonic test equipment shall not be operated by anyone who has not been certified and instructed in the use of ultrasonic testing by the designated person. The responsible person shall prepare a test method that describes the general procedures, requirements, and techniques for ultrasonic scanning of ceramic chips.
- d. Two previously determined bad capacitors of the same dielectric material and size of the parts under test shall be added to the lot for testing.
- e. The test facility shall maintain adequate verification of the results of the ultrasonic examination.

4.6.2 Pre-termination destructive physical analysis (see 3.6). Capacitors shall be examined as specified in [EIA-469](#) and in accordance with table XIV.

TABLE XIV. Pre-termination destructive physical analysis sample size.

Lot size	Minimum sample size	Accept	Reject
1 - 500	14	0	1
501 - 10,000	32	1	2
10,001 - 35,000	50	2	3
35,001 - 500,000	80	3	4

4.6.3 Visual examination (see 3.7). Capacitors shall be examined under magnification as specified in the applicable appendix and shall meet the visual requirements of [3.25](#) for leaded capacitors and [appendix B](#) for nonleaded capacitors.

4.6.4 Pre-encapsulation terminal strength (leaded capacitors only) (see 3.8). Capacitors shall be examined as specified in [appendix C](#) and in accordance with table XV.

TABLE XV. Pre-encapsulation terminal strength.

Lead configuration	Lead pull minimum	Sample size
Radial per lead	1.8 kg (4.0 lbs)	5 samples
Axial per lead	All styles except CKS11 and CKS12 - 1.8 kg (4.0 lbs.)	5 samples
	CKS11 and CKS12 styles - 0.9 kg (2.0 lbs.)	
Dual-in-line package	2.14 kg (4.7 lbs.)	5 samples

MIL-PRF-123D  
W/AMENDMENT 1

4.6.5 Radiographic inspection (encapsulated capacitors only). The leaded capacitors shall be radiographed in accordance with 3.9 and appendix D. The following details shall apply:

- a. Number of views: One view perpendicular to the plane of the leads for both axial and radial lead style capacitors (see appendix D, figure D-2).
- b. Inspection of films: The films shall be inspected on a back-lighted illuminator using a minimum of 10X magnification.
- c. Defects: Capacitors containing any defects as specified in 3.9 and appendix D, figure D-3, shall be rejected.
- d. Summary data of inspection results: A summary of the results of radiographic inspection (number of parts inspected, number accepted, number rejected) shall be included on the report of group A inspection furnished with each shipment of capacitors.
- e. Retention of films: Radiograph films and test reports shall be retained by the manufacturer for a minimum period of 10 years.

4.6.6 Thermal shock and voltage conditioning (see 3.10). Capacitors shall be subjected to the tests of 4.6.6.1 and 4.6.6.2, as applicable (see tables IX, XI, and XII).

4.6.6.1 Thermal shock. Capacitors shall be tested in accordance with method 107 of MIL-STD-202. The following details shall apply:

- a. Test condition A, except that in step 3, sample units shall be tested at +125°C.
- b. For qualification testing: 100 cycles of thermal shock.
- c. For group A testing: 20 cycles of thermal shock.
- d. For group B testing: 100 cycles of thermal shock.

4.6.6.2 Voltage conditioning (see 3.10). The intent of voltage conditioning is that all parts be exposed to a predetermined test voltage  $\pm 5$  percent, for a defined time and temperature. Voltage conditioning is done to help eliminate infant mortality capacitors from the production lot. All parts offered for electrical testing shall be subjected to the voltage conditioning test in 4.6.6.2.1 or optional voltage conditioning test in 4.6.6.2.2. It shall be verifiable that all parts offered for electrical tests have been exposed to the required voltage conditioning for the required time duration. When the optional voltage conditioning test of 4.6.6.2.2 is used, the traveler shall include the specific accelerated voltage used and the test time. See figure 4 for a suggested test circuit. An alternate test circuit can be used, provided the notes of figure 4 are followed.

4.6.6.2.1 Standard voltage conditioning (see 3.10). Standard voltage conditioning shall be started after completion of the thermal shock test. The voltage conditioning shall consist of applying twice the rated voltage to the units at the maximum rated temperature of +125°C +4°C, -0°C for a minimum of 168 hours and a maximum of 264 hours. Voltage conditioning may be terminated at any time during the 168 to 264 hour time interval, provided that the number of failures detected during the last 48 hours of test meets the PDA requirements specified in table XVI. Failures shall be determined by blown fuses or hot IR failures. Voltage shall be applied and shall reach maximum value within 2 minutes, maximum. After completion of the exposure period, the following electrical tests shall be performed:

- a. Insulation resistance (+125°C). Note: This step may be skipped if step c is done at +125°C with +25°C test limits.
- b. Dielectric withstanding voltage.
- c. Insulation resistance (+25°C).

- d. Capacitance.
- e. Dissipation factor.

The manufacturer has the option of performing these electrical tests in any order except insulation resistance shall always be done after dielectric withstanding voltage. If the voltage conditioning test is performed with individual fuses in series with each part, any part tested in a position where a fuse fails shall be tested for insulation resistance and dielectric withstanding voltage. If the part meets the initial requirements for insulation resistance and dielectric withstanding voltage, the part shall be rejected but shall not count against the PDA in [table XVI](#). The manufacturer also has the option to not test parts with fuse failures and count these toward the PDA.

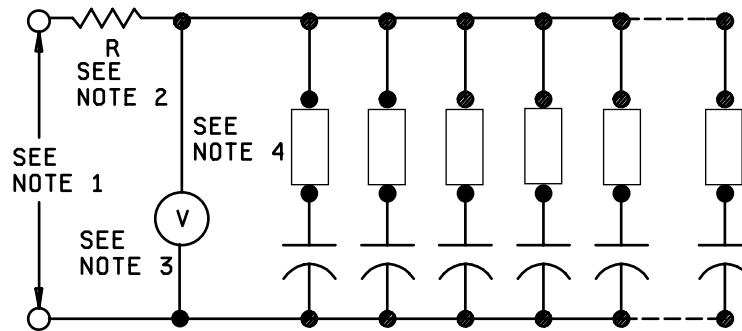

NOTES:

1. The power supply shall be capable of supplying the required test voltage.
2. The current limiting device shall be a resistor and/or a fuse. The current shall be limited to no less than 30 milliamperes (mA) and no more than 10 A.
3. There shall be a voltage monitor that will trigger an alarm and shut off the test if the applied voltage drops by more than 5 percent.
4. Fuses and resistors are optional. The value of the resistors and fuses shall be such that they do not restrict the power supply's ability to provide the required test voltage to the device under test ( $\pm 5$  percent).
5. The capacitor bank shall be no less than 10 capacitors.

FIGURE 4. Voltage conditioning circuitry.

4.6.6.2.2 Optional voltage conditioning (see 3.10). The manufacturer, with approval from the qualifying activity, may perform an optional voltage conditioning test instead of the standard voltage conditioning test of 4.6.6.2.1. All conditions of 4.6.6.2.1 apply, with the exception of the voltage applied, the test time, and the time required for meeting the PDA. The accelerated condition selected for the optional voltage conditioning shall be used for the duration of the test. At no time shall a combination of standard and optional voltage conditioning be allowed on the same samples. The minimum time duration,  $T_{\text{test}}$  minimum, and the time required for meeting the PDA,  $T_{\text{test}}$  PDA, shall be calculated as follows:

$$T_{\text{test}} (\text{min.}) = \frac{1344}{(E_{\text{test}} / E_{\text{rated}})^3} \qquad T_{\text{test}} (\text{PDA}) = \frac{384}{(E_{\text{test}} / E_{\text{rated}})^3}$$

- Where:
- $2 \times E_{\text{rated}} \leq E_{\text{test}} \leq 4 \times E_{\text{rated}}$
  - $E_{\text{test}}$  = Applied voltage
  - $E_{\text{rated}}$  = Rated voltage of the capacitor
  - $T_{\text{test}} (\text{min.})$  = Minimum test time in hours
  - $T_{\text{test}} (\text{PDA})$  = Time required for meeting the PDA

MIL-PRF-123D  
W/AMENDMENT 1

4.6.6.3 Voltage conditioning at +85°C for nonleaded solder coated chip capacitors (see 3.10). Voltage conditioning (see table XI) shall consist of applying twice the rated voltage to the units at +85°C for 48 hours. The voltage conditioning circuit (see figure 4) and measurements of insulation resistance (+125°C), dielectric withstanding voltage, insulation resistance (+25°C), capacitance, and dissipation factor shall be the same as that described in 4.6.6.2.1.

TABLE XVI. Percent defectives allowable for subgroup 1, group A inspection.

Style	PDA last 48 hours during voltage conditioning at +125°C 1/	PDA overall including voltage conditioning at +85°C
CKS05	1 unit or 0.1 percent	3 percent
CKS05S	1 unit or 0.1 percent	3 percent
CKS06	1 unit or 0.2 percent	5 percent
CKS06S	1 unit or 0.2 percent	5 percent
CKS07	1 unit or 0.2 percent	5 percent
CKS26	1 unit or 0.2 percent	5 percent
CKS11	1 unit or 0.1 percent	3 percent
CKS12	1 unit or 0.1 percent	3 percent
CKS14	1 unit or 0.1 percent	3 percent
CKS15	1 unit or 0.2 percent	5 percent
CKS16	1 unit or 0.2 percent	5 percent
CKS51	1 unit or 0.1 percent	3 percent
CKS52	1 unit or 0.1 percent	3 percent
CKS53	1 unit or 0.1 percent	3 percent
CKS54	1 unit or 0.1 percent	3 percent
CKS28	1 unit or 0.1 percent	3 percent
CKS29	1 unit or 0.1 percent	3 percent
CKS22	1 unit or 0.1 percent	3 percent
CKS23	1 unit or 0.1 percent	3 percent
CKS24	1 unit or 0.1 percent	3 percent

1/ For optional voltage conditioning, the time required for meeting the PDA shall be calculated with the T(test) PDA equation in 4.6.6.2.2.

4.6.7 Capacitance (see 3.11). Capacitors shall be tested in accordance with method 305 of MIL-STD-202. The following detail and exception shall apply:

- a. Test frequency: 1 megahertz  $\pm$ 100 kHz when the nominal capacitance is 100 pF or less for BX and BR characteristics, and 1,000 pF or less for BP and BG characteristics. One kHz  $\pm$ 100 Hz when the nominal capacitance is greater than above.
- b. Voltage: A root-mean-square potential of 1.0  $\pm$ 0.2 volt.

4.6.8 Dissipation factor (see 3.12). The dissipation factor shall be measured with a capacitance bridge or other suitable method at the frequency and voltage specified in 4.6.7. The inherent accuracy of the measurement shall be  $\pm$ 2 percent of the reading plus 0.1 percent dissipation factor (absolute) unless otherwise specified. Suitable measurement techniques shall be used to minimize errors due to the connections between the measuring apparatus and the capacitor.

4.6.9 Dielectric withstanding voltage (see 3.13).

MIL-PRF-123D  
W/AMENDMENT 1

4.6.9.1 Dielectric. Capacitors shall be tested in accordance with [method 301 of MIL-STD-202](#). The following details shall apply:

- a. Magnitude and nature of test voltage: 250 percent to 400 percent of the direct current rated voltage.
- b. Duration of application of test voltage:  $5 \pm 1$  seconds. The test voltage shall be raised from 0 to the specified value within 1 second, maximum.
- c. Points of application of test voltage: Between the capacitor-element terminals.
- d. Limiting value of surge current: Shall be limited between 30 and 50 milliamperes.
- e. Examination after test: Capacitors shall be examined for evidence of damage and breakdown.

4.6.9.2 Body insulation (qualification only). Leaded capacitors shall be tested as specified in 4.6.9.1 with the following exception: Points of application of test voltage: The encapsulated body of the capacitors shall be brought into intimate contact with a conductive material not less than .0625 inch (1.588 mm) and not more than .125 inch (3.18 mm) away from the lead wires. A direct current potential of 500 V dc shall be applied between the two leads connected together and the tape or foil for a period of  $5 \pm 1$  seconds. The test circuit shall be so arranged that the surge current does not exceed 50 mA.

4.6.10 Insulation resistance (see 3.14). Capacitors shall be tested in accordance with [method 302 of MIL-STD-202](#). The following details shall apply:

- a. Test potential: Rated voltage.
- b. Special conditions: If a failure occurs at a relative humidity above 50 percent, the insulation resistance may be measured again at any relative humidity less than 50 percent.
- c. Points of measurement: Between the mutually insulated points.

4.6.11 Destructive physical analysis (see 3.4.1 and 3.15). Capacitors shall be examined in accordance with 4.6.11.1 (group 1), 4.6.11.2 (group 2), and [table XVII](#).

4.6.11.1 Group 1.

4.6.11.1.1 Leaded capacitors. After lead attachment and before encapsulation, or after removing the encapsulation. Group 1 samples shall be inspected for lead attachment, other assembly-related defects in accordance with [EIA-469](#), and the applicable criteria of [appendix A](#) of this specification.

4.6.11.1.2 Nonleaded capacitors. To be performed after the application of the final termination coating. The criteria of [appendix B](#) of this specification shall be used.

4.6.11.2 Group 2.

4.6.11.2.1 Leaded capacitors. Without removing the encapsulation. Group 2 samples shall be inspected in accordance with [EIA-469](#) and for the following encapsulation defects:

- a. Voids between the encapsulant and the capacitor body or lead wires.
- b. Cracks or voids in the encapsulation. There shall be no voids in the encapsulant greater in diameter than 50 percent of the encapsulant wall thickness.

4.6.11.2.2 Nonleaded capacitors. The group 2 samples shall be inspected in accordance with 5.1.7 through 5.1.9 inclusive, of [EIA-469](#). Primary metallization shall only be included if it was not included in the chip lot in-process DPA.

MIL-PRF-123D  
W/AMENDMENT 1

TABLE XVII. Destructive physical analysis sample size.

Lot size	Minimum sample size <u>1/</u>	
	Group 1 <u>2/</u>	Group 2 <u>3/</u>
1 - 500	5	3
501 - 10,000	10	4
10,001 - 35,000	25	7
35,001 - 500,000	40	10

1/ No failures allowed

2/ See 4.6.11.1.

3/ See 4.6.11.2.

4.6.12 Terminal strength (see 3.16).

4.6.12.1 Terminal strength (leaded capacitors) (see 3.16). Capacitors shall be tested in accordance with [method 211 of MIL-STD-202](#). The following details and exceptions shall apply:

- a. For dual-in-line package (DIP) capacitors, bend leads to full radial (down) position before testing.
- b. Test condition A:
  - (1) Method of holding: Capacitors shall be held by one terminal and the load shall be applied gradually to the other terminal.
  - (2) Applied force:  $2 \pm 1$  kilograms.
- c. Test condition C: Applicable to radial-lead and DIP units only.
- d. Test condition D: Applicable to axial-lead units only.
- e. Examination after test: Capacitors shall be visually examined for evidence of loosening or rupturing of the terminals.

4.6.12.2 Terminal strength (nonleaded capacitors) (see 3.16). Capacitors shall be tested in accordance with [method 211 of MIL-STD-202](#). The following details and exceptions shall apply:

- a. Test condition A:
  - (1) Capacitors shall have nail head, lead wire (.020 inch to .025 inch) (.51 mm to .64 mm) attached as shown on [figure 5](#), prior to pull test.
  - (2) Method of holding: Capacitors shall be held by one terminal and the load shall be applied gradually to the other terminal.
  - (3) Applied force: [See figure 5](#).
- b. Examination after test: Capacitors shall be visually examined for evidence of loosening or rupturing of the terminals. Breakage of lead wire or solder interface, which does not expose ceramic, shall not constitute a failure.

4.6.12.3 Pre-encapsulation terminal strength (dual-in-line package (DIP) capacitors) (see 3.16). Capacitors shall be tested in accordance with [appendix C](#).

MIL-PRF-123D  
W/AMENDMENT 1

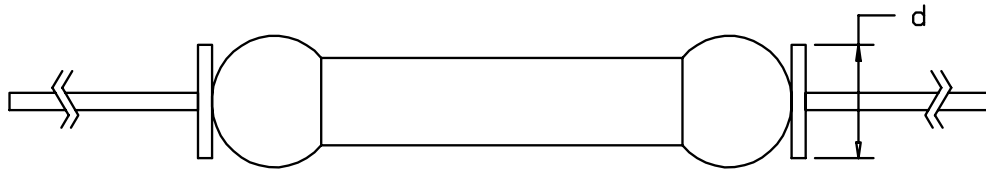

Style	Nail head diameter, d (inches)	Applied force	Inches	mm
			.005	0.13
CKS51	.040 ±.005	1 Kg ± .1	.040	1.02
CKS52	.040 ±.005	1 Kg ± .1	.045	1.14
CKS53	.040 ±.005	2 Kg ± .2		
CKS54	.040 ±.005	2 Kg ± .2		

FIGURE 5. Lead attachment for chip pull test.

4.6.13 Solderability (see 3.17).

4.6.13.1 Solderability for leaded capacitors (see 3.17.1). Capacitors shall be tested in accordance with [method 208 of MIL-STD-202](#). Two terminations shall be tested.

4.6.13.2 Solderability for nonleaded capacitors (see 3.17.2). Capacitors shall be tested in accordance with [method 208 of MIL-STD-202](#). The following details and exceptions shall apply:

- a. Each chip capacitor shall be immersed in molten solder to a depth of .020 +.010, -.000 inch or the entire capacitor may be immersed.
- b. Number of terminations to be tested: Two.
- c. Examination of terminations shall be in accordance with [3.17.2](#). In case of dispute, the percent coverage with pinholes or exposed termination material shall be determined by actual measurement in these areas, as compared to the total area.

4.6.14 Resistance to soldering heat (see 3.18).

4.6.14.1 Resistance to soldering heat for leaded capacitors (see 3.18.1). Capacitors shall be tested in accordance with [method 210 of MIL-STD-202](#). The following details and exceptions shall apply:

- a. Capacitors shall be immersed using procedure 1.
- b. Depth of immersion in the molten solder: To within 0.050 inch from the capacitor body ([see figure 6](#)).
- c. Test condition B: Except that the immersion duration shall be 20 ±1 seconds.
- d. Cooling time prior to measurement after test: 10 ±1, -0 minutes.
- e. Measurements before test: Capacitance, DF and IR at +25°C shall be measured and recorded as specified in [4.6.7](#), [4.6.8](#), and [4.6.10](#), respectively.
- f. Measurements after test: Capacitors shall meet the requirements of [3.18.1](#). Capacitance, dissipation factor, and insulation resistance at +25°C shall be measured and recorded as specified in [4.6.7](#), [4.6.8](#), and [4.6.10](#), respectively.

MIL-PRF-123D  
W/AMENDMENT 1

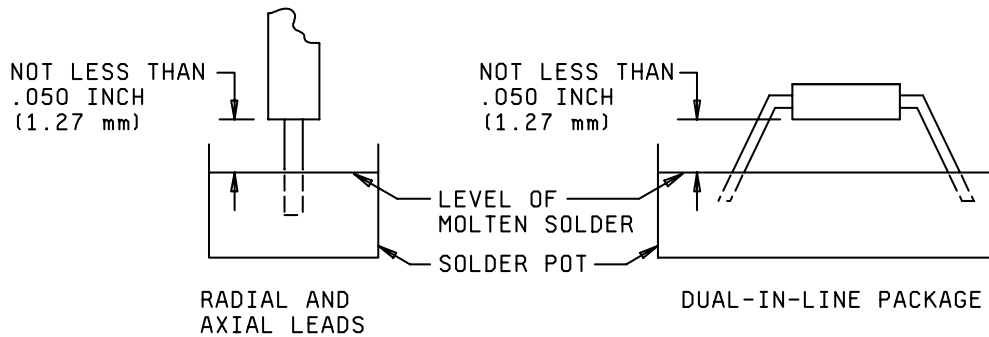

FIGURE 6. Depth of immersion in molten solder.

4.6.14.2 Resistance to soldering heat (nonleaded capacitors) (see 3.18.2). Capacitors shall be tested in accordance with method 210 of MIL-STD-202. The following details shall apply:

- a. Capacitors shall be immersed using procedure 1, two times.
- b. Test condition B: Except the solder temperature shall be +230°C, +5°C, -0°C, and the duration shall be 5, +1, -0 seconds.
- c. Cooling time prior to measurement after test: 10 minutes minimum and up to 24 hours maximum.
- d. Measurements before test: Capacitance, dissipation factor, and insulation resistance at +25°C shall be measured and recorded as specified in 4.6.7, 4.6.8, and 4.6.10, respectively.
- e. Examination and measurement after test: Capacitors shall meet the requirements of 3.18.2. Capacitance, dissipation factor, and insulation resistance at +25°C shall be measured and recorded as specified in 4.6.7, 4.6.8, and 4.6.10, respectively.

4.6.15 Voltage-temperature limits (see 3.19). The temperature of each capacitor shall be varied as specified in table XVIII. Capacitance measurements shall be made at the frequency and voltage specified in 4.6.7. The dc rated voltage need only be applied to the capacitor in each of step E through step G inclusive, until voltage stability is reached and the capacitance measurement is made. Capacitance measurements shall be made at each step specified in table XVIII and at a sufficient number of intermediate points between step B and step G to establish a true characteristic curve. Capacitance measurements at each temperature shall be taken at 5 minute intervals and shall be stopped and recorded when two successive readings indicate a capacitance change of less than one percent.

4.6.15.1 Voltage-temperature limits for quality conformance inspection. Capacitance measurements shall be made as specified in 4.6.7, except that the measurements shall be made only for steps C, D, E, and G of table XVIII.

TABLE XVIII. Voltage-temperature limit cycle.

Step	Voltage, dc	Temperature, °C
A	None	+25 ±2
B	None	-55 ±2
C <u>1/</u>	None	+25 ±2
D	None	+125 ±2
E	Rated	+125 ±2
F	Rated	+25 ±2
G	Rated	-55 ±2

1/ Reference point.

MIL-PRF-123D  
W/AMENDMENT 1

4.6.16 Moisture resistance (see 3.20).

4.6.16.1 Humidity, steady state, low voltage. Capacitors shall be tested in accordance with [method 103 of MIL-STD-202](#), condition A. The following details and exceptions shall apply. Note: At no time during test shall voltage greater than 1.5 volts be applied to any capacitor under test.

- a. Initial measurements: Capacitance.
- b. Test: Capacitors shall be subjected to an environment of +85°C with 85 percent relative humidity for 240 hours minimum. Cycling shall not be performed. A dc potential of  $1.3 \pm 0.25$  volts shall be applied continuously through a 100,000-ohm resistance to each device under test.
- c. Final measurements: On completion of the above test, remove capacitors from the chamber and allow 3 hours, 30 minutes,  $\pm 30$  minutes to dry and stabilize at +25°C before performing the insulation resistance (IR), through a 100 kilohm resistor at 1.3 volts  $\pm 0.25$  volts, and capacitance in accordance with [4.6.10](#) and [4.6.7](#), respectively.
- d. Visual examination: After final measurements, the capacitors shall be examined for evidence of mechanical damage and obliteration of marking.
- e. Leads may be attached to chip capacitors for mounting and loading purposes. Mechanical loading is acceptable.

4.6.16.2 Moisture resistance, normal voltage. Capacitors shall be tested in accordance with [method 106 of MIL-STD-202](#). The following detail and exceptions shall apply:

- a. Initial measurements: Capacitance.
- b. Number of cycles: 20 continuous cycles.
- c. Tests: during the first 10 cycles only, a direct current potential of 50 volts shall be applied across the capacitor terminals. Once each day a check shall be performed to determine whether a capacitor has shorted. Vibration cycle of step 7b shall not be performed.
- d. Final measurements and examination: On completion of step 6 of the final cycle, capacitors shall be conditioned at 25°C  $\pm 5$ °C and a relative humidity of 30 percent to 60 percent for a period of 18 hours minimum, 24 hours maximum, and shall be visually examined for evidence of mechanical damage and obliteration of marking; capacitance, dielectric withstanding voltage, and insulation resistance at 25°C shall then be measured as specified in [4.6.7](#), [4.6.9](#), and [4.6.10](#), respectively.
- e. Leads may be attached to chip capacitors for mounting and loading purposes. Mechanical holding is acceptable.

4.6.17 Vibration, high frequency (leaded capacitors only) (see 3.21). Capacitors shall be tested in accordance with [method 204 of MIL-STD-202](#). The following details and exceptions shall apply:

- a. Mounting: Capacitors shall be rigidly mounted on a mounting fixture by the body. The leads shall be secured to rigidly supported terminals, so spaced that the length of each lead from the capacitor is approximately 0.375 inch (9.52 mm) when measured from the edge of the supporting terminals. Leads shall be within 15° of being parallel. When securing leads, care shall be taken to avoid pinching the leads. The mounting fixture shall be so constructed as to preclude any resonance within the test range. An examination of the mounting fixture shall be made on a vibrator. If any resonant frequencies are observed, adequate steps must be taken to damp the structure.
- b. Electrical load conditions: During the test, a direct current potential equal to 125 percent of the direct current rated voltage ([see 3.1](#)) shall be applied between the terminals of the capacitor element under test.

MIL-PRF-123D  
W/AMENDMENT 1

- c. Test condition E (50's): Except frequency range of 10 through 3,000 Hz.
- d. Duration and direction of motion: Equal amounts of time in each of three mutually perpendicular planes (total of 8 hours).
- e. Measurements during vibration: During the last cycle in each direction, an electrical measurement shall be made to determine intermittent contacts of 0.5 ms or greater duration, or open- or short-circuiting.
- f. Examination after vibration: Capacitors shall be visually examined for evidence of mechanical damage.

4.6.18 Resistance to solvents (see 3.22). Capacitors shall be tested in accordance with [method 215 of MIL-STD-202](#). The following details shall apply:

- a. The marked portion of the capacitor body shall be brushed.
- b. The number of sample units to be examined shall be as specified in [table IX](#).
- c. Capacitors shall be visually examined for evidence of mechanical damage and obliteration of marking.

4.6.19 Life (at elevated ambient temperature) (see 3.23). Capacitors shall be tested in accordance with [method 108 of MIL-STD-202](#). The following details and exceptions shall apply:

- a. Minimum sample size and accept/reject criteria shall be in accordance with table XIX.
- b. Distance of temperature measurements from specimens, in inches, not applicable.
- c. Test temperature and tolerance: +125°C, +4°C, -0°C.
- d. Capacitors shall be subjected to the voltage and circuit specified in [4.6.6.2.1](#). In the event of a fuse failure, the procedure specified in [4.6.6.2.1](#) shall apply.
- e. Test duration: 4,000 hours for qualification and 1,000 hours for group B.
- f. Measurements during and after exposure: At the conclusion of 250, 1,000, 2,000, and 4,000 hours, and while the capacitors are at the applicable high-test temperature, the insulation resistance shall be measured as specified in [4.6.10](#). At the option of the manufacturer, the units may be immediately transferred (period of transfer not to exceed 15 minutes) to another chamber maintained at the same temperature for the purpose of measuring insulation resistance. The insulation resistance measurement shall be made only after the units have stabilized at the test temperature. The capacitors shall then be returned to the inspection conditions specified in [4.3](#) and shall be visually examined for evidence of mechanical damage and obliteration of marking; capacitance, dissipation factor, and insulation resistance shall be measured as specified in [4.6.7](#), [4.6.8](#), and [4.6.10](#), respectively.

TABLE XIX. Life test.

Lot size	Minimum sample size	250 - 4,000 hours	
		Accept	Reject
1 - 1,200	25	0	1
1,201 - 10,000	80	1	2
10,001 - 150,000	125	2	3

MIL-PRF-123D  
W/AMENDMENT 1

5. PACKAGING

5.1 Packaging. For acquisition purposes, the packaging requirements shall be as specified in the contract or order (see 6.2). When packaging of materiel is to be performed by DoD or in-house contractor personnel, these personnel need to contact the responsible packaging activity to ascertain packaging requirements. Packaging requirements are maintained by the Inventory Control Point's packaging activities within the Military Service or Defense Agency, or within the military service's system commands. Packaging data retrieval is available from the managing Military Department's or Defense Agency's automated packaging files, CD-ROM products, or by contacting the responsible packaging activity.

6. NOTES

(This section contains information of a general or explanatory nature that may be helpful, but is not mandatory.)

6.1 Intended use. The capacitors covered by this specification are intended for use in space, launch vehicles, or other high reliability applications. Capacitors covered by this specification are unique due to the fact that these devices must be able to operate satisfactorily in high reliability military systems under the following demanding conditions: 50 Gs of high frequency vibration, high humidity, and wide temperature fluctuations. These capacitors also offer very high reliability that is verified under a qualification system. Commercial components are not designed to withstand these military environmental conditions.

6.2 Acquisition requirements. Acquisition documents must specify the following:

- a. Title, number, and date of this specification, the applicable specification sheet, and the complete PIN (see 3.1).
- b. Lead length, if different from that specified (see 3.1). Lead lengths may be a minimum of 1 inch (25.4 mm) long for use in tape and reel automatic insertion equipment, when specified.
- c. Packaging requirements.

6.3 Qualification. With respect to products requiring qualification, awards will be made only for products that are, at the time of award of contract, qualified for inclusion in Qualified Products List whether or not such products have actually been so listed by that date. The attention of the contractors is called to these requirements, and manufacturers are urged to arrange to have the products that they propose to offer to the Federal Government tested for qualification in order that they may be eligible to be awarded contracts or orders for the products covered by this specification. Information pertaining to qualification of products may be obtained from the Defense Supply Center, Columbus, ATTN: DSCC-VQP, PO Box 3990, Columbus, OH 43218-3990, or by e-mail to [vqp.chief@dla.mil](mailto:vqp.chief@dla.mil).

6.3.1 Copies of SD-6, "Provisions Governing Qualification", are available online at <http://assist.daps.dla.mil/quicksearch/> or from the Standardization Document Order Desk, 700 Robbins Avenue, Building 4D, Philadelphia, PA 19111-5094.

6.4 Case insulation. It is not intended that the case insulation be subjected to sustained voltage in excess of 150 percent of the dc rated voltage of the capacitor. Supplementary insulation should be provided where the case may come in contact with higher voltage.

6.5 Tin whisker growth. The use of alloys with tin content greater than 96 percent, by mass, may exhibit tin whisker growth problems after manufacture. Tin whiskers may occur anytime from a day to years after manufacture and can develop under typical operating conditions, on products that use such materials. Conformal coatings applied over top of a whisker-prone surface will not prevent the formation of tin whiskers. Alloys of 4 percent lead, by mass, have shown to inhibit the growth of tin whiskers. For additional information on this matter, refer to [ASTM-B545](#) (Standard Specification for Electrodeposited Coatings of Tin).

MIL-PRF-123D  
W/AMENDMENT 1

6.6 Subject term (key word) listing.

High frequency vibration  
Radiographic inspection  
Space

6.7 Environmentally preferable material. Environmentally preferable materials should be used to the maximum extent possible that the material meets or exceeds the operational and maintenance requirements, and promotes economically advantageous life cycle costs. Table XX lists the Environmental Protection Agency (EPA) top seventeen hazardous materials targeted for major usage reduction. If any of these hazardous materials are required, it is recommended that it be used only when other materials cannot meet performance requirements.

Table XX. EPA top seventeen hazardous materials.

Benzene	Dichloromethane	Tetrachloroethylene
Cadmium and Compounds	Lead and Compounds	Toluene
Carbon Tetrachloride	Mercury and Compounds	1,1,1 - Trichloroethane
Chloroform	Methyl Ethyl Ketone	Trichloroethylene
Chromium and Compounds	Methyl Isobutyl Ketone	Xylene
Cyanide and Compounds	Nickel and Compounds	

\* 6.8 Amendment notations. The margins of this specification are marked with asterisks to indicate modifications generated by this amendment. This was done as a convenience only and the Government assumes no liability whatsoever for any inaccuracies in these notations. Bidders and contractors are cautioned to evaluate the requirements of this document based on the entire content irrespective of the marginal notations.

MIL-PRF-123D  
W/AMENDMENT 1

APPENDIX A

PRE-ENCAPSULATION VISUAL INSPECTION CRITERIA FOR LEADED CAPACITORS

A.1. SCOPE

A.1.1 Scope. This appendix specifies the visual inspection criteria for leaded capacitors. This appendix is a mandatory part of the specification. The information contained herein is intended for compliance.

A.2. Applicable documents. This section is not applicable to this appendix.

A.3. PROCEDURES FOR INSPECTION AND REJECTION

A.3.1 Method of inspection. Each device shall be examined under 7 power minimum magnification to determine compliance with the requirements specified herein.

A.3.2 Rejection criteria for both axial and radial leaded devices. Devices that deviate from the material, design, or construction requirements specified, or that fail to meet the following requirements or those specified in A.4.1 shall be unacceptable.

A.3.2.1 Chip examination.

- a. Cracks in the ceramic.
- b. Open delaminations in chips.
- c. "Cold" solder joints (frosted or granular in appearance).
- d. Solder bridging or potential bridging between opposing terminations.
- e. Excess solder.
- f. No solder balls on leads.

A.4. SPECIFIC LEAD REJECTION CRITERIA

A.4.1 Axial leaded devices - criteria/assessment.

- a. Unit A: Ideal lead to element union. Acceptable (see figure A-1).
- b. Unit B: Solder build-up (fillet) on one side only. Acceptable (see figure A-1).
- c. Unit C: No solder build-up (fillet), but good element to chip interface. Acceptable (see figure A-1).
- d. Unit D: Edge of lead wire does not overhang the edge of the element, and full solder coverage is evidenced. Acceptable (see figure A-2).
- e. Unit E: Gap in solder joint under the nail head which reduces lead-to-element interface to less than 90 percent coverage. Rejectable (see figure A-3).
- f. Unit F: Gap in solder joint under the nail head which reduces lead-to-element interface to less than 90 percent coverage. Rejectable (see figure A-3).
- g. Unit G: Gaps or voids in solder joint under the nail head which reduces lead-to-element interface to less than 90 percent coverage. Rejectable (see figure A-3).

MIL-PRF-123D  
W/AMENDMENT 1

APPENDIX A

- h. Unit H: Gap in solder joint under the nail head which reduces lead-to-element interface to less than 90 percent coverage. Rejectable (see figure A-3).
- i. Unit I: Diameter of lead wire overhangs side of element. Rejectable (see figure A-3). (Note: Nail head may overhang.)
- j. Unit J: Edge of lead wire does not overhang edge of element, but gap in solder joint under the nail head reduces lead-to-element interface to less than 90 percent coverage. Rejectable (see figure A-3).
- k. Unit K: Center line of nail head tilted greater than 30° beyond center line of chip. Rejectable (see figure A-3).

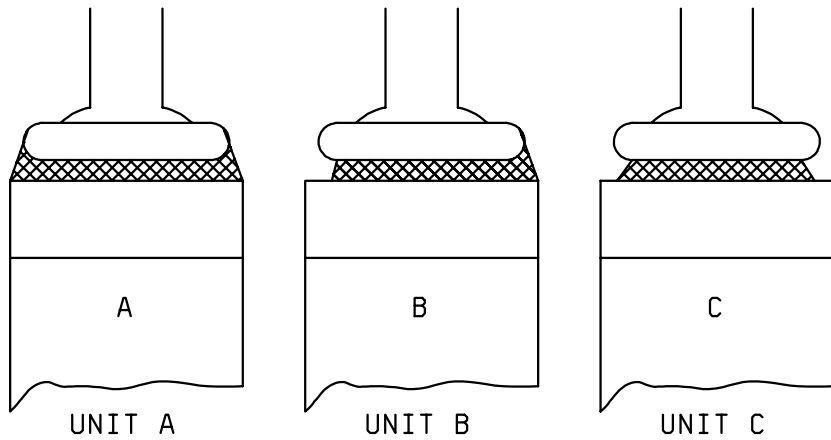

FIGURE A-1. Acceptable units.

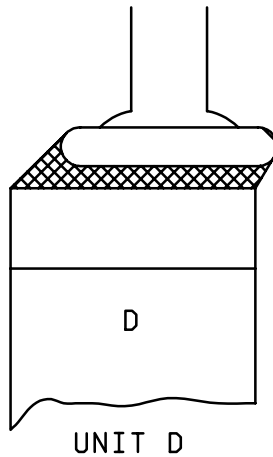

FIGURE A-2. Acceptable only by QC department.

APPENDIX A

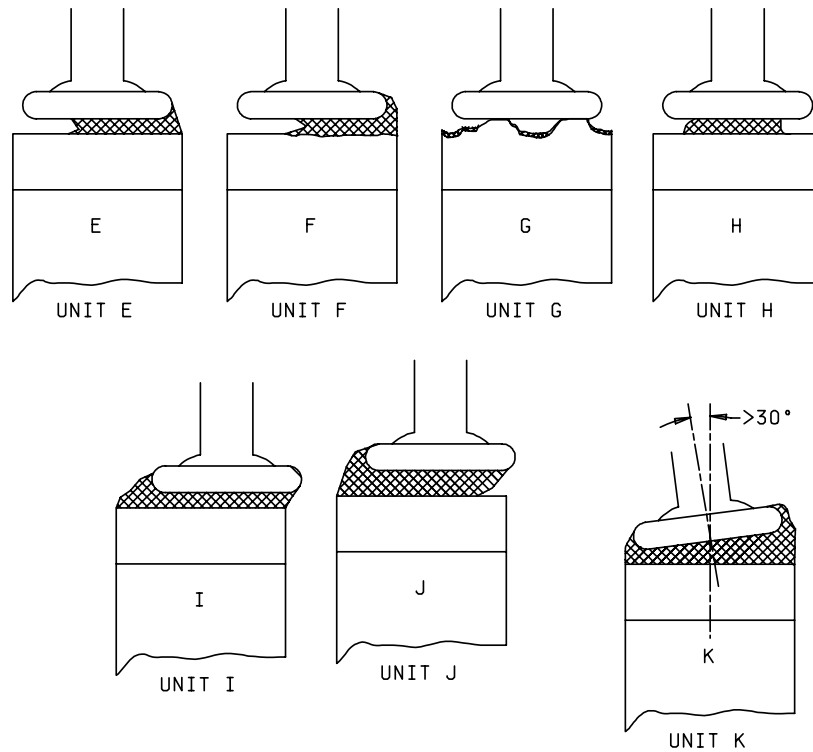

FIGURE A-3. Rejectable devices.

A.4.2 Radial leaded devices (molded) - criteria/assessment.

- a. Unit M: Ideal condition for a radial leaded device prior to encapsulation. Acceptable (see figure A-4).
- b. Unit N: Element thickness is greater than or equal to the average lead wire flat dimension. The element must be positioned such that the lead wire flat does not extend more than one-third beyond the thickness of the element. This example is rejectable (see figure A-5).
- c. Unit O: Element thickness is less than the average lead wire flat dimension. The element must be positioned such that the lead wire flat does not extend more than one-third beyond the thickness of the element. This example is rejectable (see figure A-5).
- d. Unit P: Angle between chip centerline and lead centerline shall not exceed  $30^\circ$  (see figure A-5).
- e. Unit Q: Ideal chip alignment (top view). Acceptable (see figure A-6).
- f. Unit R: If the element thickness is greater than or equal to the average lead wire flat dimension, the element must be positioned such that the lead wire flat does not extend more than one-third beyond the thickness of the element. If the element thickness is less than the average lead wire flat dimension, the element must be positioned such that the lead to element interface is a minimum of 90 percent of the available contact area. This example is rejectable (top view) (see figure A-6).

MIL-PRF-123D  
W/AMENDMENT 1

APPENDIX A

g. Unit S: This example shows various rejectable characteristics which may be observed on the radial leaded device (see figure A-7). Description of the numbered defects are as follows:

- (1) Lead-to-element interface of less than 80 percent is not acceptable.
- (2) Cut, dent, or smash in the lead wire exceeding .050 inch (1.27 mm) in length or .005 inch (0.13 mm) in depth is rejectable.
- (3) Element is not properly seated in the "saddle". Gaps in excess of .015 inch (0.38 mm) are rejectable.
- (4) Chip-outs in the ceramic surface which expose electrodes are not acceptable.

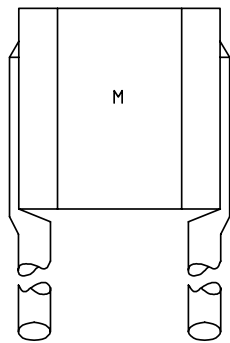

FIGURE A-4. Ideal condition (acceptable unit).

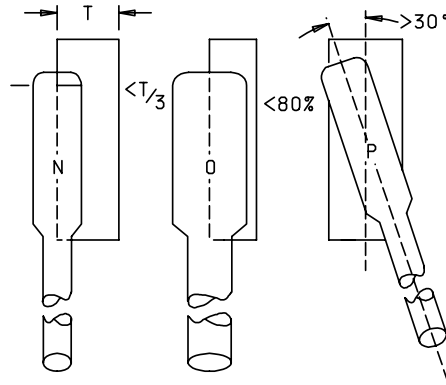

FIGURE A-5. Rejectable units.

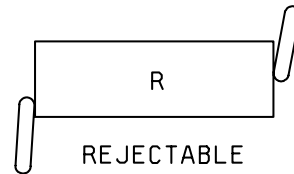
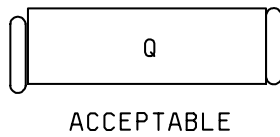

FIGURE A-6. Chip alignment.

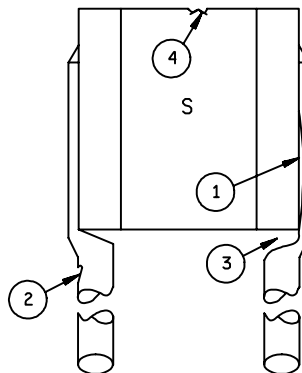

FIGURE A-7. Rejectable characteristics.

MIL-PRF-123D  
W/AMENDMENT 1

APPENDIX B

VISUAL INSPECTION CRITERIA FOR CHIP CAPACITORS

B.1. SCOPE

B.1.1 Scope. This appendix specifies the visual inspection criteria for chip capacitors. This appendix is a mandatory part of the specification. The information contained herein is intended for compliance.

B.2. APPLICABLE DOCUMENTS. This section is not applicable to this appendix.

B.3. PROCEDURES FOR INSPECTION AND REJECTION

B.3.1 Method of inspection. Each device shall be examined under 10 power magnification to determine compliance with the requirements specified herein.

B.3.2 Rejection criteria. Devices that deviate from the material, design or construction requirements specified, or that fail to meet the following requirements, shall be unacceptable.

B.3.2.1 Termination metallization.

- a. End terminals shall be completely covered. Pinholes less than or equal to .005 inch (0.13 mm) in diameter are permitted (maximum of three pinholes in each surface area).
- b. Gaps in the metallization band shall only be acceptable if the metallization band is not less than the minimum metallization band requirement specified ([see figure B-1](#)).
- c. Metallized edges shall not be reduced to less than 90 percent due to chipping or metallizing process ([see figure B-2](#)).
- d. There shall be no excess metallization or solder tear which violates the minimum pad separation ([see figure B-3](#)).
- e. There shall be no foreign material visible adhering to the solder, or voids in the solder revealing greater than 10 percent of the base metallization ([see figure B-4](#)).

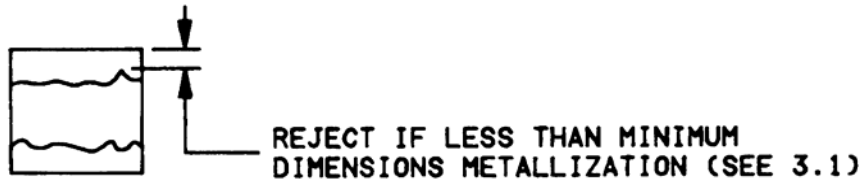

FIGURE B-1. Metallization band gaps.

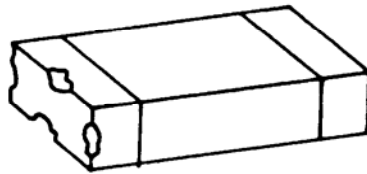

FIGURE B-2. Metallization band chipping.

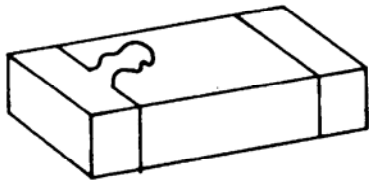

FIGURE B-3. Excessive metallization

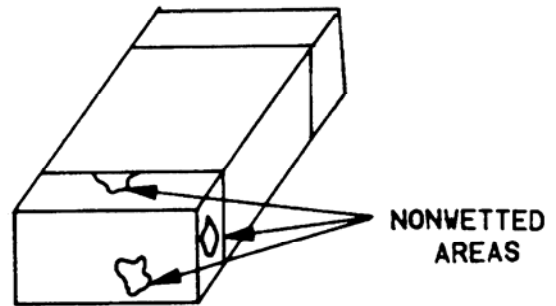

FIGURE B-4. Solder defects.

MIL-PRF-123D  
W/AMENDMENT 1

APPENDIX B

B.3.2.2 Ceramic surface examination.

- a. There shall be no cracks (see figure B-5).
- b. There shall be no delamination of ceramic layers. A delamination is the separation of ceramic layers (usually observed on sides) (see figure B-6).
- c. Striations are unacceptable (see figure B-6).
- d. Edge chip-outs shall not be greater in depth than .003 inch (0.08 mm) with respect to either plane. An edge chip-out is any region where material has been removed as a result of a fracture (see figure B-7).
- e. Rough edges shall be permitted provided they are within the allowable chip-out region as specified on figure B-7.
- f. Lips, flared edges, or irregular shapes shall not exceed limits specified on figure B-8.
- g. There shall be no fused dust or excess material on external surface that prevents a chip from lying flat, or protrude more than .003 inch (0.08 mm) out of a surface.
- h. There shall be no raised surfaces, bubbles, or blisters greater than .002 inch (0.05 mm) (usually found on top and bottom) (see figure B-9).
- i. When compared to a flat surface, the clearance (warpage) at the center of the chip shall be less than 5 percent of the length dimension (see figure B-10).
- j. A pinhole is a circular hollow or cavity no larger than .002 inch (0.05 mm) in diameter (see figure B-11). They are unacceptable if they exceed this size.
- k. There shall be no holes (voids) that expose electrode plates (see figure B-12).
- l. The marking shall be legible and complete (see figure B-13).

APPENDIX B

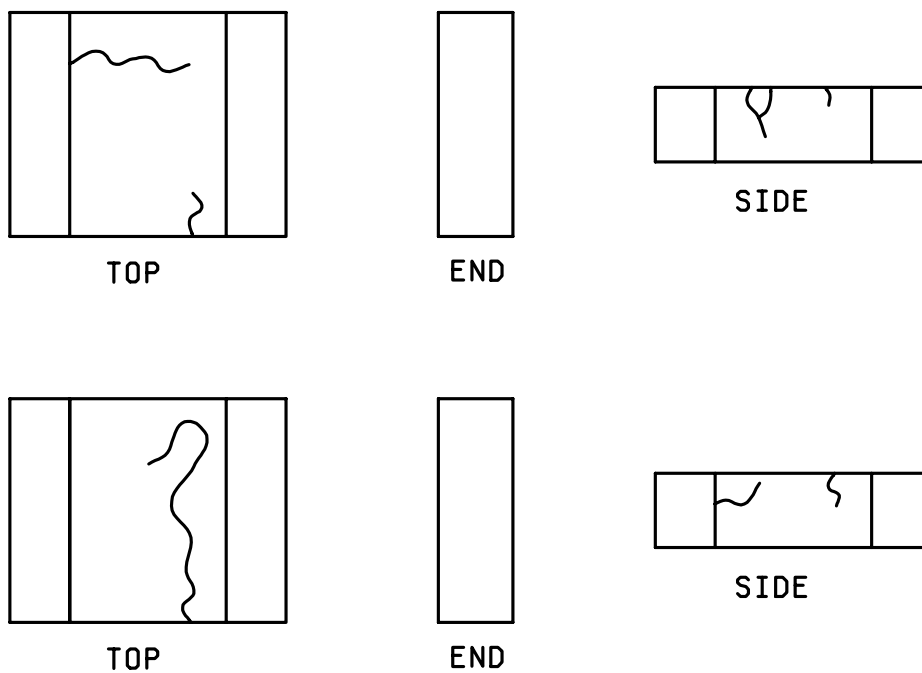

FIGURE B-5. Cracks.

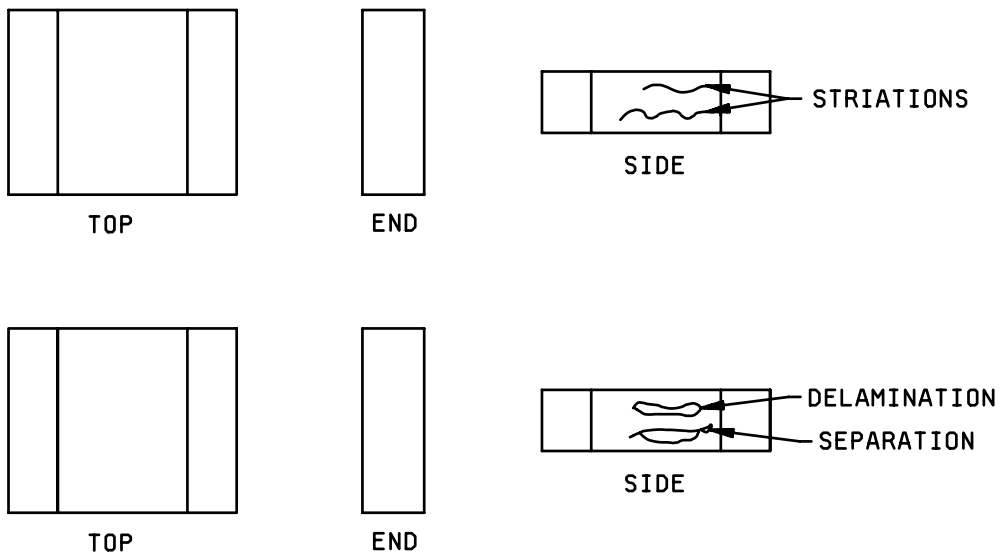

FIGURE B-6. Striations and delaminations.

MIL-PRF-123D  
W/AMENDMENT 1

APPENDIX B

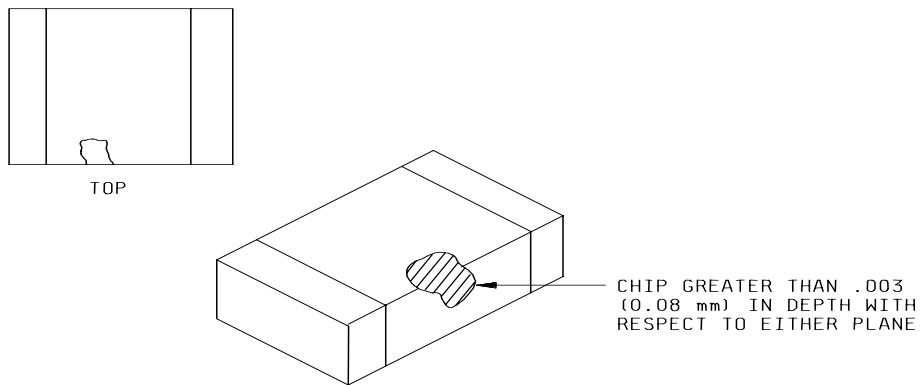

FIGURE B-7. Chip-outs.

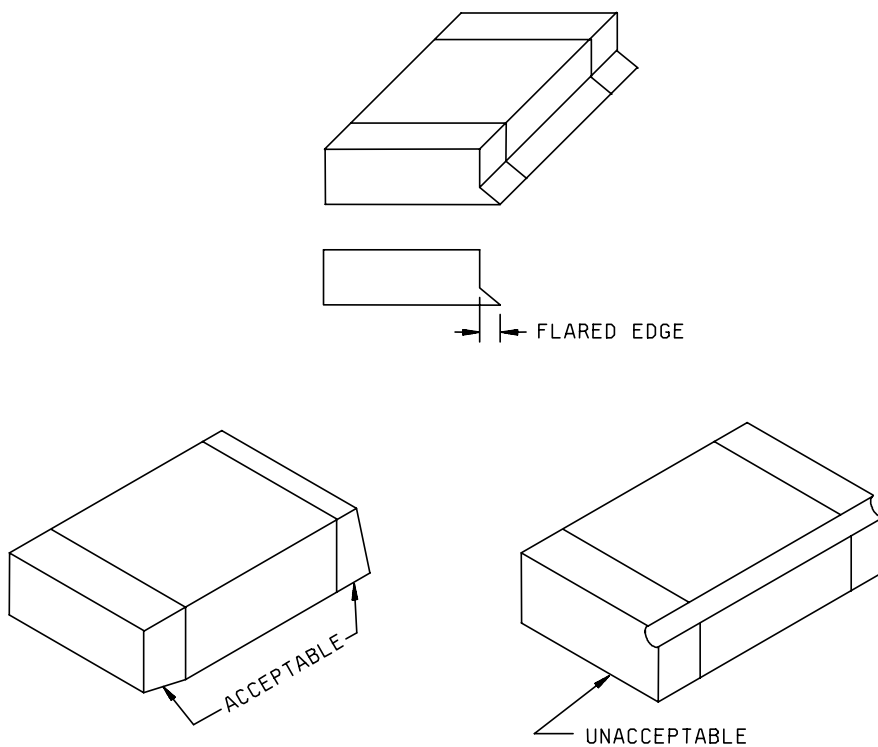

FIGURE B-8. Unacceptable lips, flared edges, or irregular shapes.

APPENDIX B

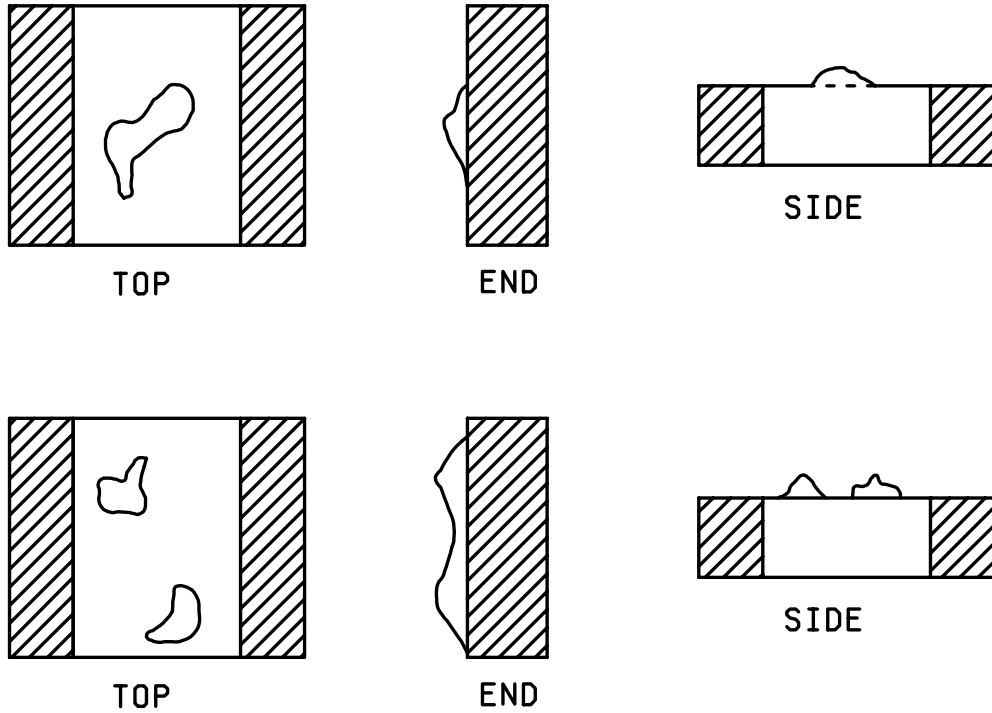

FIGURE B-9. Raised surfaces, bubbles, and blisters.

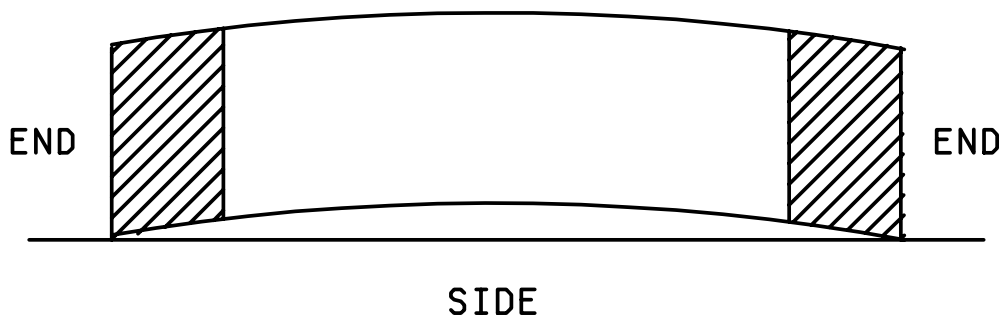

FIGURE B-10. Warpage.

APPENDIX B

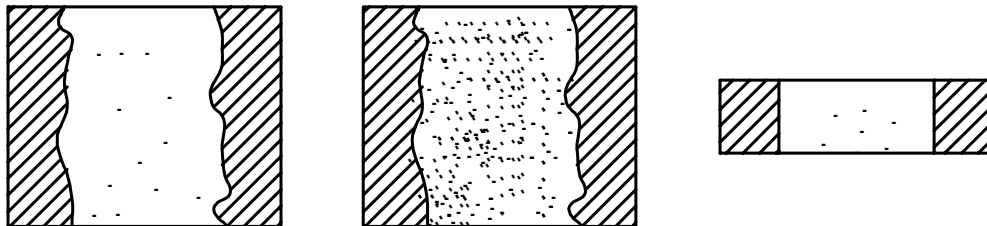

FIGURE B-11. Pinholes.

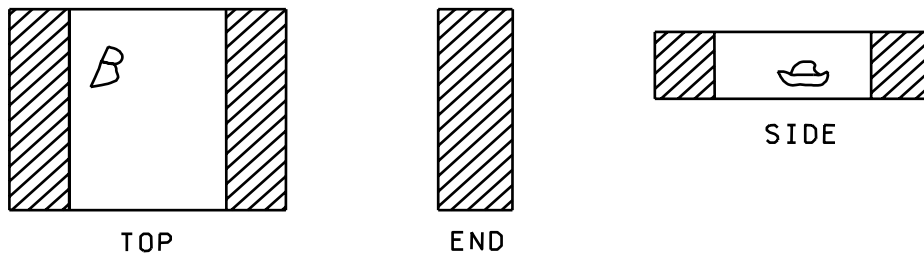

FIGURE B-12. Voids.

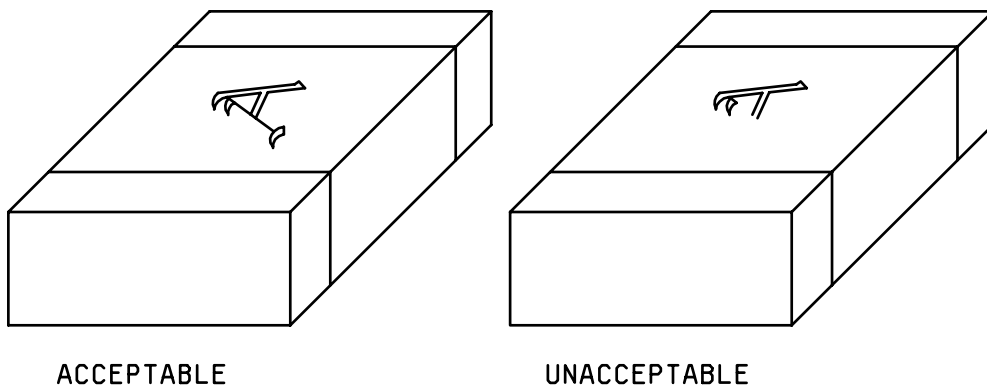

FIGURE B-13. Marking.

MIL-PRF-123D  
W/AMENDMENT 1

APPENDIX C

LEAD PULL

C.1. SCOPE

C.1.1 Scope. this appendix specifies special test procedures and methods for CKS ceramic capacitors. Details for testing of axial and radial leaded, and two-pin dual-in-line package (DIP) capacitors prior to molding or encapsulation is included. This appendix is a mandatory part of the specification. The information contained herein is intended for compliance.

C.2. APPLICABLE DOCUMENTS. This section is not applicable to this appendix.

C.3. EQUIPMENT

C.3.1 Guage and test stand. The test equipment used shall be capable of performing the required tests.

C.4. TEST METHOD

C.4.1 Radial devices. Firmly clamp the body of the capacitor into the test stand. Gradually apply an ever-increasing force to one lead at a time in the direction of the leads (see figure C-1) until the limits specified in table XV are exceeded.

C.4.2 Axial devices. Firmly clamp one lead into the test fixture. Gradually apply an increasing force (see figure C-1) until the limits in table XV are exceeded.

C.4.3 DIP devices.

- a. Place the DIP device in the test fixture in accordance with the test equipment instructions and the test facility's operating procedure.
- b. Gradually apply an ever increasing force to the capacitor body until the limits specified in table XV are exceeded. If the capacitor chip breaks during the test, resulting in a rupture force below the minimum allowed, disregard the reading and perform the test on another device.

C.4.4 Minimum rupture force. Minimum rupture force shall be in accordance with table XV.

C.5. REJECTION CRITERIA

C.5.1 Defects. If one failure occurs, additional samples in accordance with table XIV shall be retested with zero failures. If two failures occur, the lot shall be rejected.

MIL-PRF-123D  
W/AMENDMENT 1

APPENDIX C

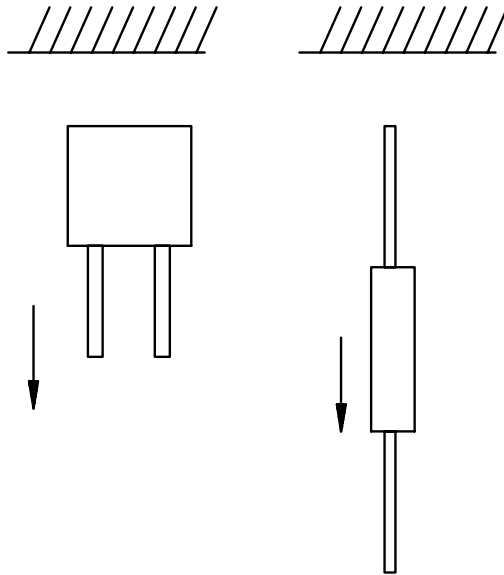

FIGURE C-1. Lead-pull direction.

MIL-PRF-123D  
W/AMENDMENT 1

APPENDIX D

RADIOGRAPHIC INSPECTION

D.1. SCOPE

D.1.1 Scope. This appendix specifies procedures and practices necessary for radiographic inspection of ceramic capacitors during qualification inspection and group A acceptance inspection. This appendix is a mandatory part of the specification. The information contained herein is intended for compliance.

D.1.2 Facilities. Radiographs of the capacitors may be made by the capacitor manufacturer or a suitable independent laboratory. In either case, facilities, equipment, personnel, and techniques shall be in accordance with the requirements specified herein.

D.1.3 Responsibility for inspection. The capacitor manufacturer shall perform the inspection of the radiograph films and acceptance/rejection of the capacitors.

D.1.4 Alternative x-ray system and procedures. The manufacturer has the option, with the qualifying activity approval, to use an alternative x-ray system and procedures to detect the defect criteria identified in this specification. This alternative system and procedures shall be documented in the MIL-STD-790 program.

D.2. APPLICABLE DOCUMENTS. This section is not applicable to this appendix.

D.3. EQUIPMENT

D.3.1 Dimensions. The dimensional values on which these requirements are based were developed using the U. S. system. Where such equivalents do not correspond to a standard metric size, the closest standardized metric equivalent size may be used.

D.3.2 Radiography. The X-ray equipment shall have sufficient voltage range to produce radiographs in accordance with this document. The equipment shall have a focal spot of 3.5 millimeters (mm) or less and shall maintain a sharply defined image at a focal film distance of 30 to 60 inches (76.20 to 152.40 centimeters).

D.3.3 Exposure factors. The X-ray exposure factors shall be selected to achieve maximum image detail within the sensitivity requirements. The film shall be exposed in accordance with the following requirements:

- a. X-ray film shall be single emulsion and of a grade defined as very fine grain.
- b. H and D film density: 1.5 to 3.0.
- c. Milliampere and time settings: Adjusted, as necessary, to obtain satisfactory exposure.

D.3.4 Film. The X-ray film shall be single emulsion and of a grade defined as very fine grain.

D.3.4.1 Sensitivity. X-ray film and equipment shall be capable of detecting metallic particles with a major dimension of .004 inch (0.10 mm) or greater.

D.3.4.2 Exposure. Exposure factors such as KVP, current, and time shall be compatible with the sensitivity requirements of D.3.4.1.

D.3.4.3 Film density. The X-ray equipment and processing techniques shall be capable of producing H and D film density of 1.5 to 3.0 in accordance with the American Standard Printing density type P-2.

D.3.4.4 Film dimensions. Radiographic film shall not exceed 14 inches (35.56 centimeters) in width and 17 inches (43.18 centimeters) in length.

MIL-PRF-123D  
W/AMENDMENT 1

APPENDIX D

D.3.4.5 Processing. The exposed X-ray film shall be processed in such manner that the film shall be free of processing defects, i.e., fingerprints, chemical spots, blemishes, etc.

D.3.4.6 Film identification. Each radiographic film shall be identified with the following information:

- a. Part manufacturer's name.
- b. Part number (as marked on part).
- c. Part cross-reference.
- d. Date or lot code (as marked on part).
- e. View number.
- f. X-ray laboratory name.
- g. Penetrameter image.
- h. Penetrameter number (see figure D-1).

D.3.5 Penetrameters. Penetrameters shall be employed in all radiographic testing and shall be as specified in figure D-1. The penetrameter image shall be used to determine radiographic quality and shall meet the following requirements:

- a. Penetrameter wires shall be visible on each radiograph.
- b. Penetrameters shall be selected to give a film density within +10 percent of the density of the area of immediate interest.
- c. Penetrameters shall be placed in diagonal corners on the source side of the film. The plane of the penetrameters shall be normal to the radiation beam. When 35-mm film strip is used, the penetrameter shall be placed in a position normally occupied by a part, and a penetrameter image shall be made (exposed) for every 50 parts or 17 inches (43.18 centimeters) of film, whichever is more convenient.
- d. Distortion of any penetrameter shall not exceed 10 percent.
- e. The spacing between wires of a penetrameter shall not be distorted by more than 10 percent. The percentage of distortion as used in this standard is defined as follows:

Percentage distortion:  $\frac{S_0 - S_1}{S_0} \times 100$  where

$S_0$  = actual wire spacing, and  
 $S_1$  = wire spacing as it appears on the X-ray film.

D.3.6 Fixtures. Suitable fixtures shall be used for mounting the electronic parts during the X-ray operation.

D.3.6.1 Mounting of parts. The capacitors may be mounted in any type of fixture, provided that any metallic portion of the fixture is not between the body of the capacitor and the film.

MIL-PRF-123D  
W/AMENDMENT 1

APPENDIX D

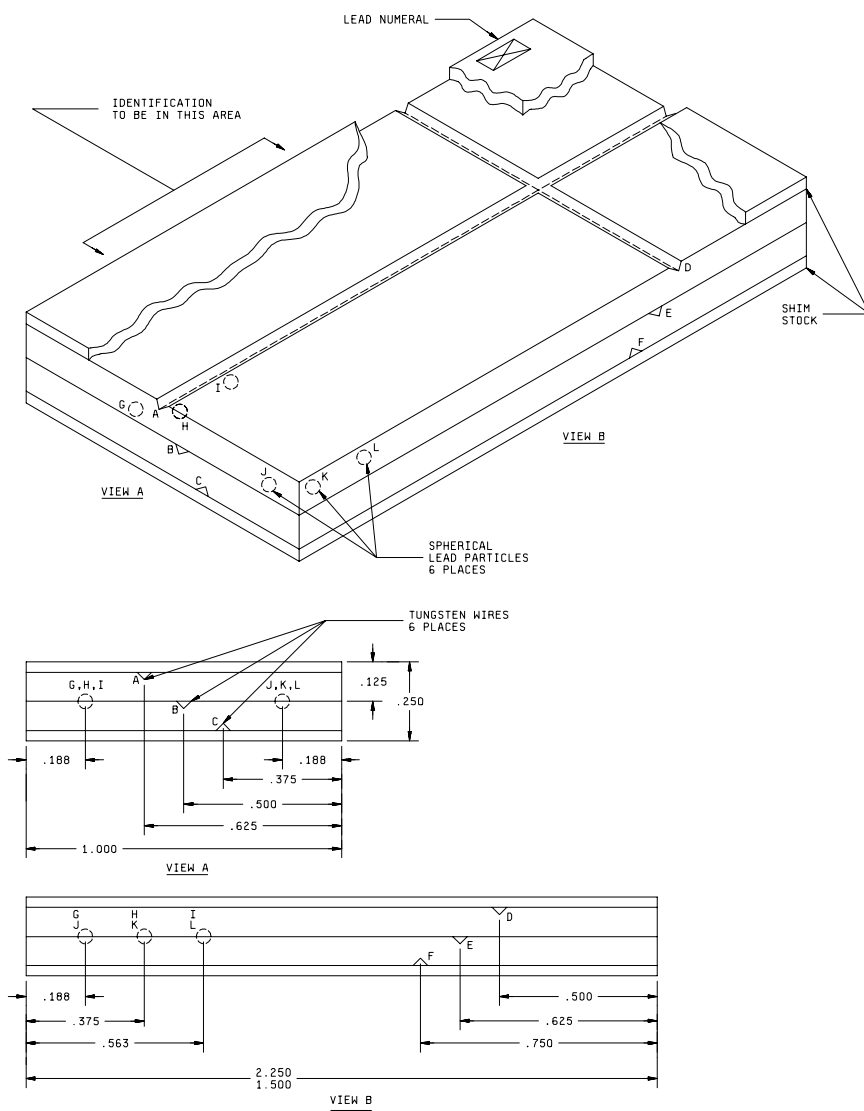

Inches	mm	Inches	mm
.125	3.18	.625	15.88
.188	4.78	.750	19.05
.250	6.35	1.000	25.40
.375	9.52	1.500	38.10
.500	12.70	2.250	57.15
.563	14.30		

FIGURE D-1. Penetrameter.

MIL-PRF-123D  
W/AMENDMENT 1

APPENDIX D

Tungsten wire diameters						Lead particle diameters						Steel shim stock
A	B	C	D	E	F	G	H	I	J	K	L	
.002 (0.05)	.001 (0.03)	.0005 (0.013)	.0005 (0.013)	.001 (0.03)	.002 (0.05)	.015 (0.38)	.010 (0.25)	.008 (0.20)	.006 (0.15)	.004 (0.10)	.002 (0.05)	None
.002 (0.05)	.001 (0.03)	.0005 (0.013)	.0005 (0.013)	.001 (0.03)	.002 (0.05)	.015 (0.38)	.010 (0.25)	.008 (0.20)	.006 (0.15)	.004 (0.10)	.002 (0.05)	.002 (0.05)
.002 (0.05)	.001 (0.03)	.0005 (0.013)	.0005 (0.013)	.001 (0.03)	.002 (0.05)	.015 (0.38)	.010 (0.25)	.008 (0.20)	.006 (0.15)	.004 (0.10)	.002 (0.05)	.005 (0.13)
.002 (0.05)	.001 (0.03)	.0005 (0.013)	.0005 (0.013)	.001 (0.03)	.002 (0.05)	.015 (0.38)	.010 (0.25)	.008 (0.20)	.006 (0.15)	.004 (0.10)	.002 (0.05)	.007 (0.18)
.003 (0.08)	.002 (0.05)	.001 (0.03)	.001 (0.03)	.002 (0.05)	.003 (0.08)	.015 (0.38)	.010 (0.25)	.008 (0.20)	.006 (0.15)	.004 (0.10)	.002 (0.05)	.010 (0.25)
.003 (0.08)	.002 (0.05)	.001 (0.03)	.001 (0.03)	.002 (0.05)	.003 (0.08)	.015 (0.38)	.010 (0.25)	.008 (0.20)	.006 (0.15)	.004 (0.10)	.002 (0.05)	.015 (0.38)
.005 (0.13)	.003 (0.08)	.002 (0.05)	.002 (0.05)	.003 (0.08)	.005 (0.13)	.015 (0.38)	.010 (0.25)	.008 (0.20)	.006 (0.15)	.004 (0.10)	.002 (0.05)	.025 (0.64)
.005 (0.13)	.003 (0.08)	.002 (0.05)	.002 (0.05)	.003 (0.08)	.005 (0.13)	.015 (0.38)	.010 (0.25)	.008 (0.20)	.006 (0.15)	.004 (0.10)	.002 (0.05)	.035 (0.89)

FIGURE D-1. Penetrameter - Continued.

NOTES:

1. Dimensions are in inches.
2. Metric equivalents are given for general information only.
3. Metric equivalents are in parentheses.
4. Wires to be tungsten, shim stock to be carbon steel, particles to be lead. Center section to be .125 inch (3.18 mm) layers of clear acrylic plastic, bonded with clear plastic cement of low X-ray density. Fasteners may be used within .250 inch (6.35 mm) or less from each corner, but shall not interfere with end use of the penetrameter. Bottom surface shall be flush.
5. All dimensions shown are  $\pm 0.005$  inch (0.13 mm), except wires, and shim stock, which shall be within standard mil tolerances and lead particles which shall be  $\pm 0.0002$  inch (0.005 mm). Groove details are not critical except that wire must be embedded flush or below surface of plastic and centered at the location shown. Particle-hole sizes are not critical, but should not exceed .031 inch (0.79 mm) in diameter and depth, and must be centered as shown,  $\pm 0.005$  inch (0.13 mm).
6. Additional layers of shim stock may be used as necessary.
7. Identification marking shall be permanent and legible. Location and size of characters are not critical but shall not interfere with or obscure the radiographic image details.

MIL-PRF-123D  
W/AMENDMENT 1

APPENDIX D

D.3.6.2 Identification of capacitors. Each capacitor shall be traceable from its position on the fixture to its corresponding image on the film until completion of film inspection and identification of any with rejectable defects.

D.3.7 Inspection and examination of radiographs (see figures D-2 and D-3). Inspection of radiographs shall be conducted by the device manufacturer. Each radiograph shall be examined, utilizing the equipment specified herein. The radiographs shall be inspected to determine that each capacitor conforms to the requirements of this document.

D.3.7.1 Viewing equipment. The radiograph shall be examined on a suitable illuminator with variable intensity, or on a viewer suitable for radiographic inspection of projection-type viewing equipment.

D.3.7.2 Magnification. A magnification of 10 power minimum shall be used for radiograph examination.

#### D.4. REPORTS AND RECORDS

D.4.1 Report of inspection. Unless otherwise specified by the contract, the testing activity shall furnish inspection reports signed by an authorized representative of the testing activity. The reports shall give the results of the radiographic inspection and shall list the part number, the number of parts inspected, the number of parts rejected, and the date of the test.

D.4.2 Records of inspection. A complete record of details of inspection shall be kept by the manufacturer or testing laboratory. The record shall list the voltage potentials and currents used in the radiographic process, the time of exposure, the distance of the source of radiation from the surface of the part, the distance of the film from the same surface, the approximate angle between the central beam of radiation and the film, the screens and filters used, the size of the focal spot, the time of development of the film, and the part number and lot or date code of the capacitors.

D.4.3 Records of radiographs. Each radiograph shall carry a radiograph inspection serial number or code letters to identify the radiograph with the examined parts shown in the radiograph. One complete set of radiographs shall be kept by the manufacturer for a period of 10 years minimum.

#### D.5. PERSONNEL

D.5.1 Radiographer. Personnel engaged in radiographic processing shall be familiar with the requirements of this specification and with all applicable documentation controlling radiographic quality of parts and materials being inspected. They shall be certified by their employer to be capable of producing radiographs which meet the requirements of all applicable documentation.

D.5.2 Radiographic interpreters. Personnel engaged in the interpretation of radiographs shall be familiar with the requirements of this specification and with all applicable documentation controlling radiographic quality of parts and materials being inspected. They shall be certified by their employer to be capable of evaluating radiographs to determine conformance of parts and materials to the requirements of all applicable documentation.

D.5.3 Vision. The minimum vision requirements for visual acuity of personnel inspecting film shall be as follows:

- a. Distant vision shall equal 20/30 in at least one eye, either corrected or uncorrected.
- b. Near vision shall be such that the individual can read Jaeger type no. 2 at a distance of 16 inches (40.64 centimeters) either corrected or uncorrected.

D.5.4 Vision tests. Vision tests shall be performed by an oculist, optometrist, or by other professionally recognized personnel. One year from the effective due date of original certification, and each year thereafter, certified personnel shall be required to pass the vision tests specified herein.

APPENDIX D

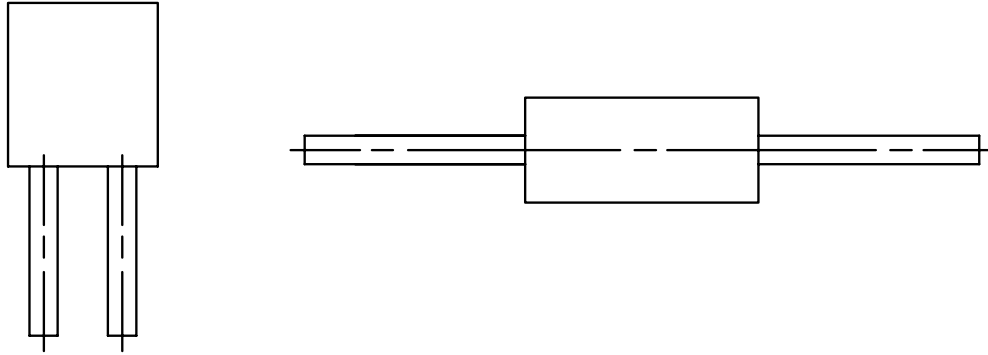
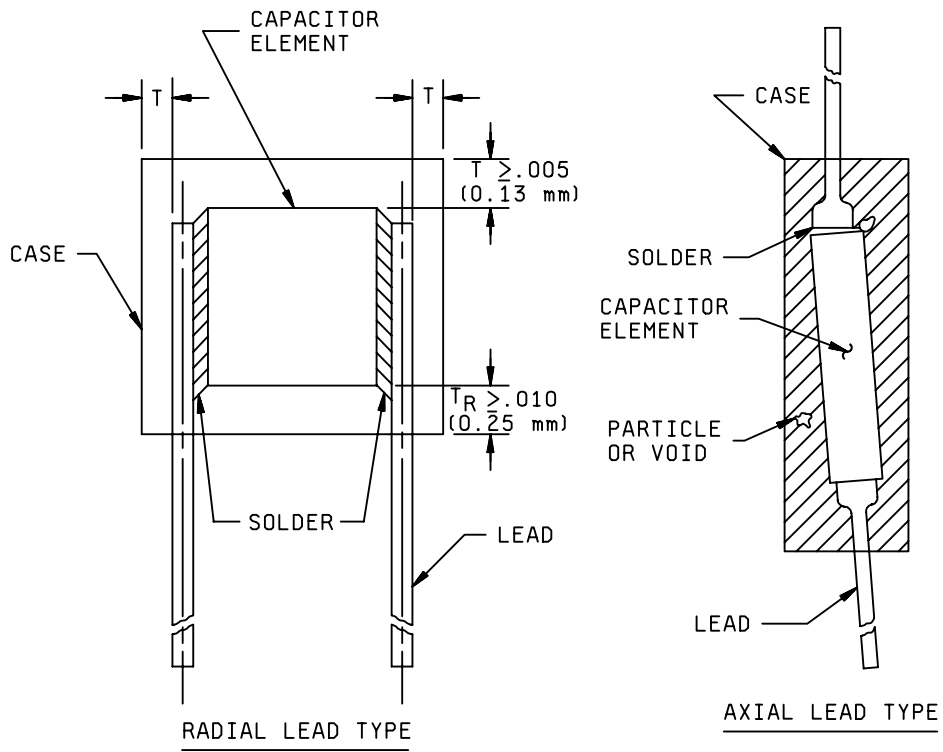

FIGURE D-2. Viewing planes for radiographic inspection.



NOTE:  $T_R$  is measured to the point at which the lead diameters are increased above their nominal dimensions by the solder meniscus.

FIGURE D-3. Acceptance criteria for radiographic inspection.

MIL-PRF-123D  
W/AMENDMENT 1

APPENDIX D

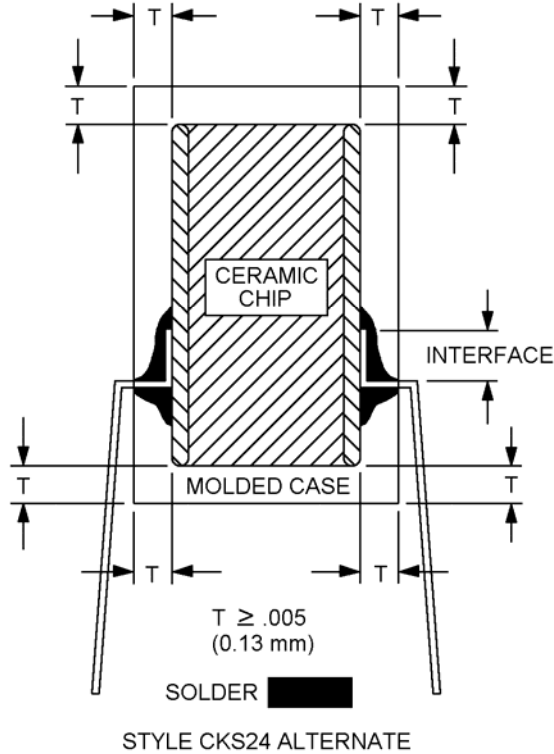
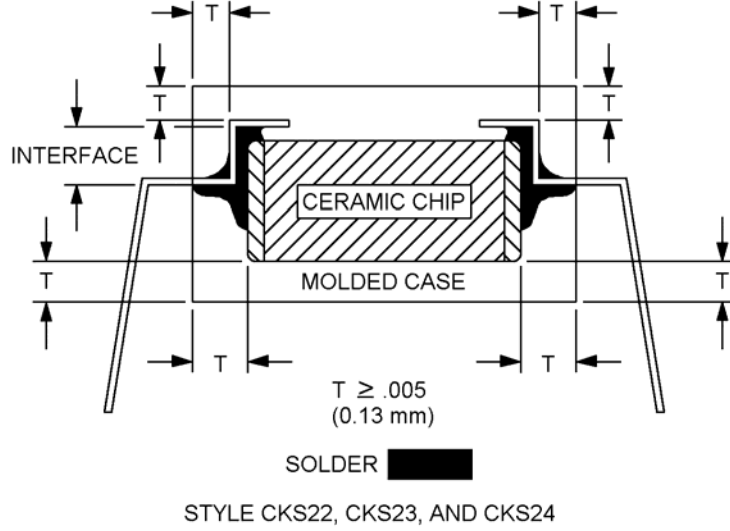

FIGURE D-3. Acceptance criteria for radiographic inspection - Continued.

MIL-PRF-123D  
W/AMENDMENT 1

APPENDIX E

PROCEDURE FOR QUALIFICATION INSPECTION

E.1. Scope. This appendix details the procedure for submission of samples, with related data, for qualification inspection of capacitors covered by this specification. The procedure for extending qualification of the required sample to other capacitors covered by this specification is also outlined herein. There shall be no combining of styles, operating voltage, or characteristic. Each shall be qualified separately. This appendix is a mandatory part of the specification. The information contained herein is intended for compliance.

E.2. APPLICABLE DOCUMENTS. This section is not applicable to this appendix.

E.3. SUBMISSION

E.3.1 Qualification based on similar established reliability (ER) styles. The manufacturer seeking qualification for a CKS style who is qualified to "R" failure rate level of a similar ER style (see table E-1) shall submit to test the total samples specified in table IX, divided equally into groups consisting of the highest capacitance value for each combination of voltage rating and characteristic.

TABLE E-1. Similar ER styles.

CKS style	Similar style	CKS style	Similar style	CKS style	Similar style
CKS05-BP	CCR05	CKS12-BP	CCR76	CKS24	CKR24
CKS05-BX	CKR05	CKS12-BX	CKR12	CKS26	CKR06
CKS05S-BP	CCR05	CKS14-BP	CCR77	CKS28-BG	CDR11
CKS05S-BX	CKR05	CKS14-BX	CKR14	CKS28-BP	CDR12
CKS06-BP	CCR06	CKS15-BP	CCR78	CKS29-BG	CDR13
CKS06-BX	CKR06	CKS15-BX	CKR15	CKS29-BP	CDR14
CKS06S-BP	CCR06	CKS16-BP	CCR79	CKS51	CDR01, CDR31
CKS06S-BX	CKR06	CKS16-BX	CKR16	CKS52	CDR02
CKS07-BP	CCR07	CKS22-BP	CKR22	CKS53	CKR03
CKS07-BX	N/A	CKS22-BX	CKR22	CKS54	CDR06
CKS011-BP	CCR75	CKS23-BP	CKR23		
CKS011-BX	CKR11	CKS23-BX	CKR23		

E.3.2 Qualification not based on similar established reliability styles. A sample of the size required in table IX, of the highest capacitance value in each voltage rating and characteristic in each style for which qualification is sought shall be submitted. For example, style CKS05 shall require 752 total sample units to qualify for the entire style.

E.3.3 Qualification of nonleaded CKS style chips by similarity from CDR style chips (MIL-PRF-55681). Manufacturers that are currently qualified to at least one nonleaded chip style in MIL-PRF-123 and are qualified to FRL 'S' of the equivalent MIL-PRF-55681 style are eligible for qualification by similarity from MIL-PRF-55681 parts to MIL-PRF-123 parts. The values of the MIL-PRF-55681 parts must be equal to or greater than the values of the MIL-PRF-123 parts and the parts must meet the minimum dielectric thickness requirement of MIL-PRF-123. The manufacturer shall request the qualifying activity to add them to the qualification. The equivalent styles are shown in the following table.

MIL-PRF-123 Style	MIL-PRF-55681 Style
CKS51 (/10)	CDR31 (/7); CDR01 (/1)
CKS52 (/11)	CDR33 (/9)
CKS53 (/12)	CDR03 (/1)
CKS54 (/13)	CDR06 (/3)
CKS55 (/21)	CDR32 (/8)
CKS56 (/22)	CDR34 (/10)
CKS57 (/23)	CDR35 (/11)

MIL-PRF-123D  
W/AMENDMENT 1

APPENDIX E

E.3.4 Description of items. The manufacturer shall submit a detailed description of the capacitors being submitted for inspection, including body, electrode material, terminal leads, etc.

E.4. EXTENT OF QUALIFICATION

E.4.1 Restrictions on qualification. Capacitance-range qualification shall be restricted to values equal to and less than the capacitance value submitted. Capacitance-tolerance qualification will be restricted to tolerances equal to and wider than the tolerance submitted. DC rated voltage, operating temperature range, and voltage-temperature limit qualification shall be restricted to that submitted.

MIL-PRF-123D  
W/AMENDMENT 1

Custodians:

Navy - EC  
Air Force - 19  
DLA - CC  
NASA - NA

Preparing activity:

DLA - CC

(Project 5910-2006-014)

Review activities:

Air Force - 11

NOTE: The activities listed above were interested in this document as of the date of this document. Since organizations and responsibilities can change, you should verify the currency of the information above using ASSIST Online database at <http://assist.daps.dla.mil>.