

F-18-35

INCH-POUND

MIL-C-83526/15(CR)
9 JUNE 1989

MILITARY SPECIFICATION SHEET
CONNECTOR, FIBER OPTIC, CIRCULAR, HERMAPHRODITIC,
DUST COVER, 2 POSITIONS

This specification is approved for use by the Department of the Army and is available for use by all Departments and Agencies of the Department of Defense.

The requirements for acquiring the product described herein shall consist of this specification sheet and the issue of the following specification listed in that issue of the Department of Defense Index of Specifications and Standards (DODISS) specified in the solicitation: MIL-C-83526

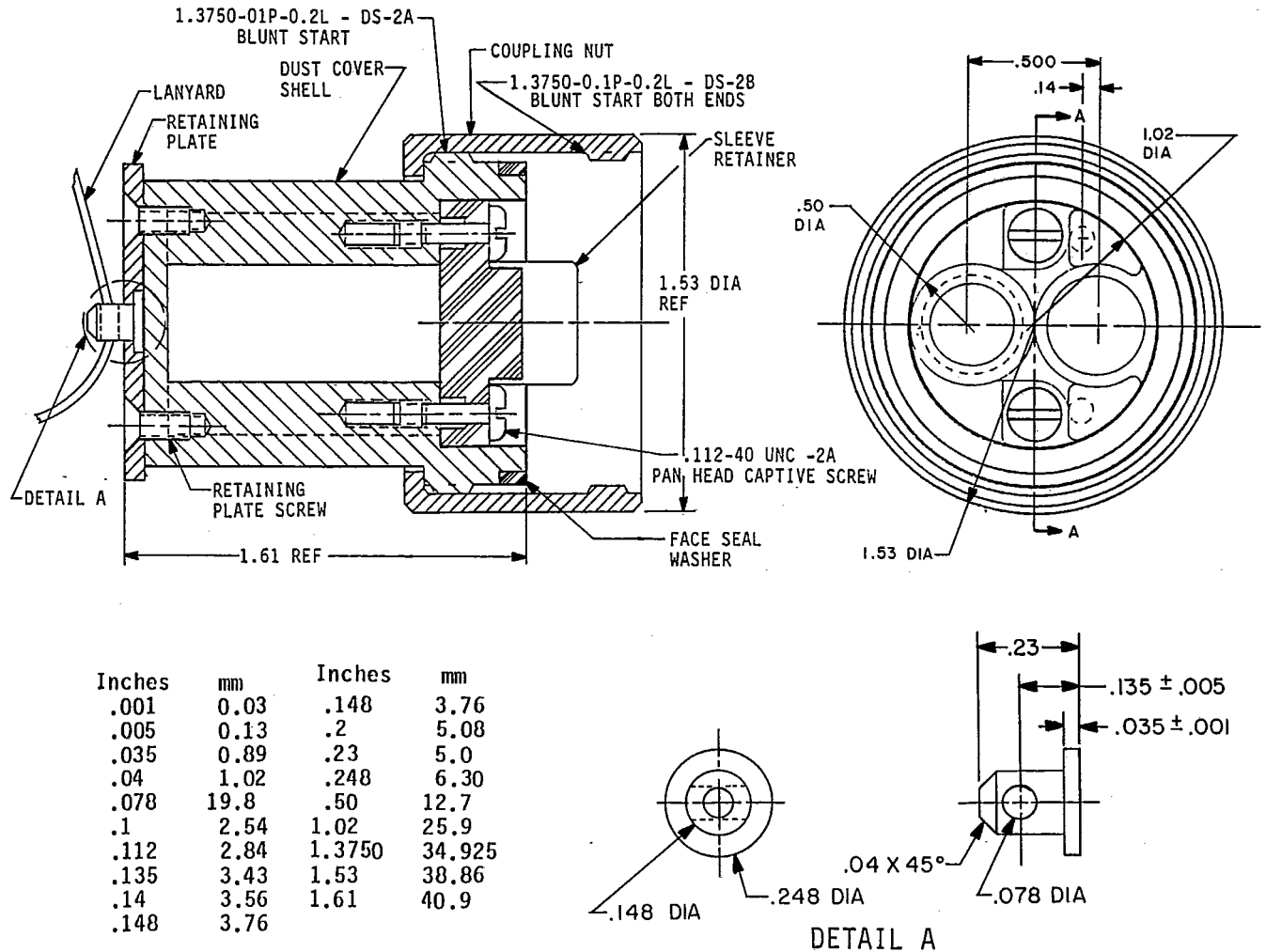
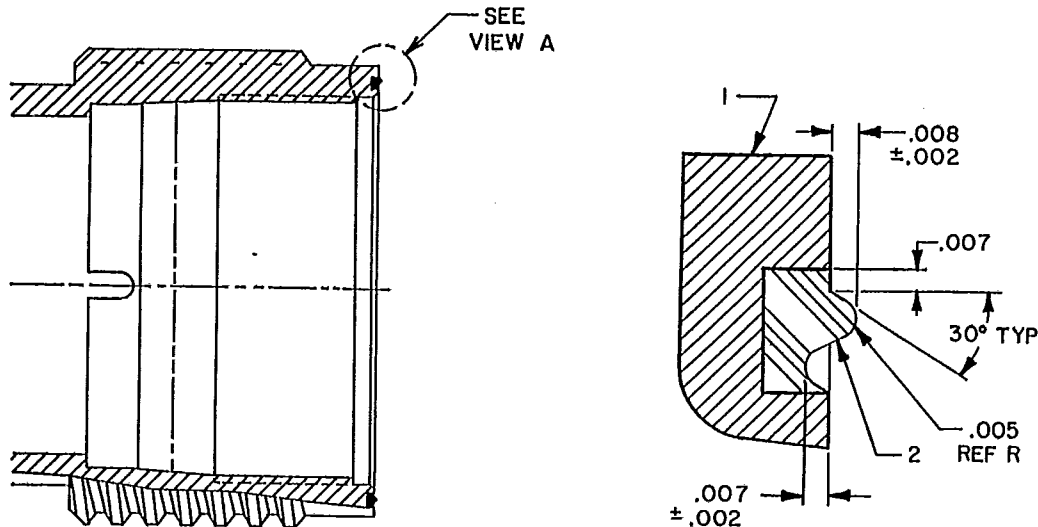

FIGURE 1. Dust cover.

AMSC N/A
DISTRIBUTION STATEMENT-A.

MIL-C-83526/15(CR)



VIEW A
FACE SEAL WASHER DETAIL

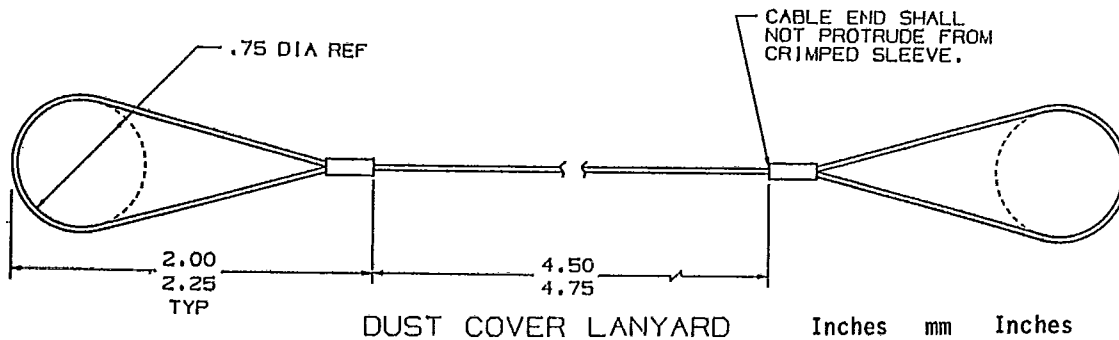

DUST COVER LANYARD

Inches	mm	Inches	mm
.002	0.05	.75	19.1
.005	0.13	2.00	50.8
.007	0.18	2.25	57.2
.008	0.20	4.50	11.4
		4.75	120.7

NOTES:

1. Dimensions are in inches.
2. Metric equivalents are given for general information only.
3. Unless otherwise specified, tolerances are $\pm .010$ (0.25 mm) for three place decimals, $\pm .03$ (0.8 mm) for two place decimals and $\pm .1$ (2.5 mm) for one place decimals. Angular tolerances are $\pm 0^\circ 30'$.
4. Unless otherwise specified, dimensions are symmetrical about centerlines.
5. The part number shall be placed on the dust cover shell.

FIGURE 1. Dust cover - Continued.

MIL-C-83526/15(CR)

REQUIREMENTS:

Dimensions and configurations: See figure 1.

Weight: 0.5 pound maximum.

Coupling force: 3 to 10 pounds.

Coupling torque: 5 to 12 inch pounds.

Finish: The connector shall be cadmium finished, olive drab, in accordance with QQ-P-416, type II, class 3.

Materials: See table I.

TABLE I. Material description.

Parts description	Material	Finish
Screws for retaining plate	Stainless steel	Passivation in accordance with QQ-P-35
Retaining plate	Aluminum 6061-T6 or 2024-T3/T4	Olive drab cadmium per QQ-P-416, type II, class 3, 500 hours extended salt spray
Dust cover shell	Aluminum 6061-T6 or die cast aluminum 380	Olive drab cadmium per QQ-P-416, type II, class 3, 500 hours extended salt spray
Coupling nut	Aluminum 6061-T6	Olive drab cadmium per QQ-P-416, type II, class 3, 500 hours extended salt spray
Sleeve retainer	Ryton R4	None
Screws for sleeve retainer	Stainless steel	Passivation in accordance with QQ-P-35
Lanyard	Stainless steel cable nylon coated	

Epoxy: Not applicable.

Installation and removal tools: Not applicable.

Threads: Applicable, except threads shall be metric in accordance with FED-STD-H28 or inch-series in accordance with FED-STD-H28 and MIL-STD-1373.

MIL-C-83526/15(CR)

Termini: Not applicable.

Optical performance: Not applicable.

Part or Identifying Number (PIN): PIN example: M83526/15-01. Fiber optical yellow band: Not applicable.

Inserts marking: Not applicable.

Inserts retention axial strength: Not applicable.

Inserts retention radial strength: Not applicable.

Terminus cleaning: Not applicable.

Terminus retention: Not applicable.

Terminus insertion and removable forces: Not applicable.

Maintenance aging: Not applicable.

Mating durability: Not applicable.

Impact: Not applicable.

Twist test: Not applicable.

Cable seal flexing: Not applicable.

Cable retention: Not applicable.

Crush resistance: Applicable, except test load shall be 450 pounds.

External bending moment: Not applicable.

Thermal shock: Applicable, except upper temperature shall be 71°C.

Shock: Applicable, except test condition A shall be utilized.

Salt spray: Applicable, except condition A of method 1001 shall be used.

Altitude: Not applicable.

Coupling force: Not applicable.

Fluid immersion: Not applicable.

Water pressure or freezing: Applicable, except minimum depth shall be 1.0m for a period of not less than 24 hours. Exposure in a chamber at -20°C after immersion is not required. Test shall be accomplished using 2 sets of samples: in-line connectors mated with dust caps and bulkhead connectors mated with dust caps.

Ozone exposure: Not applicable.

MIL-C-83526/15(CR)

Fungus resistance: Samples shall be tested in accordance with method 508.1, procedure I of MIL-STD-810. Following the test, examination of the test samples shall reveal no evidence of deterioration of component parts or constituent materials which will adversely affect performance.

Quality conformance and periodic inspection: D85045/08-B2A, or an equivalent approved by the qualifying activity, shall be used for quality conformance and periodic inspection.

Qualification inspection sample size: Applicable, except the following minimum test samples shall be provided for each connector series:

- a. Six in-line connectors mated with six dust covers. Larger sample sizes to allow parallel testing is allowed.
- b. Six bulkhead connectors mated with six dust covers. Larger sample sizes to allow parallel testing is allowed.

Retention of qualification: Applicable, except the contractor shall forward a report of 24-month intervals.

Quality conformance inspection sample unit preparation: Applicable, except in the cases where no MIL-C-85045 qualified sources exist, cable shall be specified by the qualifying activity.

Periodic inspection sampling plan: Applicable, except sample units shall be selected every 24 months.

Qualification inspection shall consist of performing the inspections and optical tests specified in table II herein, in the sequence shown.

Group A inspection shall consist of performing the inspections and optical tests specified in table III herein, in the sequence shown.

Group B inspection shall consist of performing the inspections and optical tests specified in table IV herein, in the sequence shown.

Group C inspection shall consist of performing the inspections and optical tests specified in table V herein, in the sequence shown.

Group C sampling plan: Sample units which have passed group B inspection shall be selected in accordance with table V.

NOTE:

This dust cover mates with itself, MIL-C-83526/12 in-line connector, MIL-C-83426/13 bulkhead connector, and MIL-C-83526/14 test plug.

MIL-C-83526/15(CR)

TABLE II. Qualification inspection.

Inspection MIL-C-83526
<p><u>Group I</u> (All sample units) <u>1</u>/ Physical conformance Size Weight Color Identification marking Workmanship</p> <p><u>Group II</u> (3 sample units) Humidity Mechanical shock Vibration Connector engagement and disengagement forces Coupling torques Water pressure/frezzing</p> <p><u>Group III</u> (3 sample units) Crush resistance Salt spray Sand and dust Fungus Flammability</p>

1/ Sample units - Number indicated means that the number of connectors, backshell or accessories that shall be tested.

TABLE III. Group A inspection.

Inspection MIL-C-83526
Color Workmanship Identification marking

MIL-C-83526/15(CR)

TABLE IV. Group B inspection.

Inspection MIL-C-83526
Connector engagement and disengagement forces Coupling torques

TABLE V. Group C inspection.

Inspection	Sample quantity
<u>Subgroup 1 (6 month interval)</u>	
Mechanical shock	2 units
Vibration	2 units
Crush resistance	2 units
Humidity	2 units
<u>Subgroup 2 (12 month interval)</u>	
Flammability	2 units
Salt spray	2 units
Sand and dust	2 units
Water pressure/freezing	2 units
Fungus	2 units
Size	2 units
Weight	2 units

CONCLUDING MATERIAL

Preparing activity:
Army - CR

Agent:
DLA - ES

(Project 6060-A022-7)