

## DETAIL SPECIFICATION

CONNECTORS, ELECTRIC, RECTANGULAR, NONENVIRONMENTAL,  
MINIATURE, POLARIZED SHELL, RACK AND PANEL,  
GENERAL SPECIFICATION FOR

This amendment forms a part of MIL-DTL-24308E dated 2 November 1999, and is approved for use by all Departments and Agencies of the Department of Defense.

## PAGE 2

2.3, add the following ASTM specifications:

ASTM D 4507 - Thermoplastic Polyester (TPES) Materials.

ASTM D 5927 - Thermoplastic Polyester (TPES) Injection and Extrusion Materials Based on ISO Test Methods.

## PAGE 4

3.3.1 delete and substitute:

3.3.1 Reference critical interface, materials, platings and processes. The identified reference critical interface, materials, platings, and processes have been established to provide assurances that connectors manufactured to this specification will properly interface to similar industry standard or government specified connector systems without problems of electrochemical contamination of critical electrical or mechanical interfaces or generation of incompatible mechanical interface surface wear products. The manufacturers of connectors supplied to this specification are allowed to use alternate recognized industry standard materials, platings, and processes from those identified in 3.3. Alternate materials, platings and processes used must be coordinated with the qualifying activity as part of the qualification process. Use of alternates to those referenced guidance items by the supplier must not result in inferior short or long term performance or reliability of supplied connectors as compared with connectors manufactured using the referenced materials, platings, or processes. Short or long term failures or reliability problems due to use of these alternates shall be the responsibility of the supplier.

3.3.4.2.2.1 delete and substitute:

3.3.4.2.3.1 Contact mating area. The contact mating area as shown on figure 1 shall be gold plated 50 microinches thick (1.27 $\mu$ m) minimum in accordance with ASTM B488, type 3, grade C, class 1.27, over nickel plating (see 3.3.4.2.2).

3.3.4.2.2.2 delete and substitute:

3.3.4.2.3.2 Terminations. Terminations shall be plated as follows:

- a. Solder cups: 100 microinches minimum tin-lead plated in accordance with SAE AMS-P-81728, 50 to 95 percent tin.
- b. Insulation displacement: 100 microinches minimum tin-lead plated in accordance with SAE AMS-P-81728, 50 to 95 percent tin.
- c. Printed wiring tails: 100 microinches minimum tin-lead plated in accordance with SAE AMS-P-81728.

3.3.5.1, delete and substitute:

"3.3.5.1 Insert. Insert material shall conform to SDG-F or GDI-30F in accordance with ASTM D5948 or type GPT-30F or GET-30F in accordance with ASTM D4507 or ASTM D5927 or MIL-M-24519, for classes D, G, M, and N connectors. Insert dielectric materials for classes H and K shall be glass."

MIL-DTL-24308E  
AMENDMENT 1

PAGE 13

Table XI, delete and substitute:

TABLE XI. Qualification inspection. 1/

Inspection	Requirement paragraph	Test method paragraph	Connector class 2/					
			1	2	3	4	5	
Group I								
Visual and mechanical inspection	3.1, 3.3, 3.4, 3.6, and 3.7	4.5.2	X	X	X	X	X	
Magnetic permeability (classes N and M) 3/	3.5.1	4.5.3			X	X		
Maintenance aging (crimp type)	3.5.2	4.5.4	X		X			
Contact insertion and removal forces	3.5.3	4.5.5	X		X			
Mating and unmating force	3.5.4	4.5.6	X		X			
Contact retention	3.5.5	4.5.7	X	X	X	X		
Dielectric withstanding voltage: 3/								
At sea level	3.5.6	4.5.8.1	X	X	X	X	X	
At altitude	3.5.6	4.5.8.2	X	X	X	X	X	
Cable retention (flat cable only)	3.5.7	4.5.9	X	X	X	X	X	
Insulation resistance at ambient temperature 3/	3.5.8	4.5.10	X	X	X	X	X	
Contact resistance	3.5.9	4.5.11			X	X	X	
Contact engagement and separation forces	3.5.10	4.5.12		X		X	X	
Mating and unmating force	3.5.4	4.5.6	X	X	X	X	X	
Temperature cycling (classes G, H, and N)	3.5.11	4.5.13	X	X	X	X	X	
Temperature cycling (classes D, K, and M)	3.5.11.1	4.5.13.1	X	X	X	X	X	
Air leakage (classes H and K)	3.5.12	4.5.14						X
Humidity	3.5.13	4.5.15	X	X	X	X	X	
Dielectric withstanding voltage	3.5.6	4.5.8	X	X	X	X	X	
Insulation resistance	3.5.8	4.5.10	X	X	X	X	X	
Vibration	3.5.14	4.5.16	X	X	X	X	X	
Shock	3.5.15	4.5.17	X	X	X	X	X	
Durability	3.5.16	4.5.18	X	X	X	X	X	
Contact engagement and separation forces	3.5.10	4.5.12		X		X	X	
Mating and unmating force	3.5.4	4.5.6	X	X	X	X	X	
Salt spray (corrosion)	3.5.17	4.5.19	X	X	X	X	X	
Contact resistance	3.5.9	4.5.11		X		X	X	
Mating and unmating	3.5.4	4.5.6	X	X	X	X	X	
Contact retention	3.5.5	4.5.7	X	X	X	X		
Oversize pin exclusion	3.5.18	4.5.20		X		X		
Contact resistance	3.5.9	4.5.11		X		X		
Resistance to test probe damage	3.5.19	4.5.21		X		X		
Contact engagement and separation forces	3.5.10	4.5.12		X		X		
Fluid immersion 3/	3.5.20	4.5.22	X	X	X	X	X	
Mating and unmating force 3/	3.5.4	4.5.6	X	X	X	X	X	
Insert retention	3.5.21	4.5.23	X	X	X	X	X	
Contact pin strength	3.5.22	4.5.25						
Visual and mechanical inspection	3.1, 3.3, 3.4, and 3.6	4.5.2	X	X	X	X	X	
Thermal vacuum outgassing (classes D, K, and M) 4/	3.5.24	4.5.26	X	X	X	X	X	
Group II 5/, 6/								
Resistance to solder heat	3.5.25	4.5.27		X		X	X	
Group III								
Solderability 5/	3.5.23	4.5.24		X		X	X	
Contact pin strength	3.5.22	4.5.25		X		X	X	

See footnotes on next page.

4.4.3.1.1, delete and substitute:

4.4.3.1.1 Sampling plan.

Group I: Sample connectors consisting of two mated pairs of each class, of each type, of each style of termination, with the largest insert arrangement and all the nonmetallic materials, including lubricants, of one connector of classes D, K, and M for which retention of qualification is desired shall be selected every 36 months. If production of a particular PIN is not current, the group B tests must take place at the time production is resumed. The testing shall revert to the original schedule, which is applied to a newly qualified product. If group B testing on classes G and N, D and M, or G, N, D, M is desired, one completely assembled plug and receptacle of each class shall be subjected to the examinations and tests in lieu of two of a single class.

Figure A-2, Arrangement 2, delete and substitute:

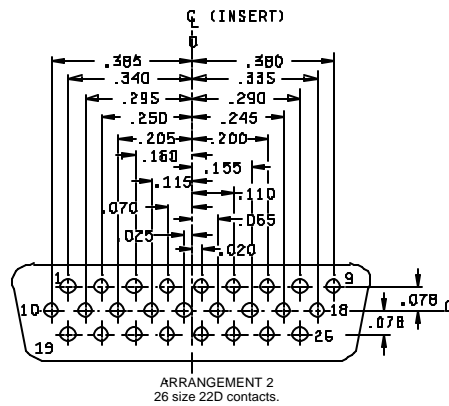
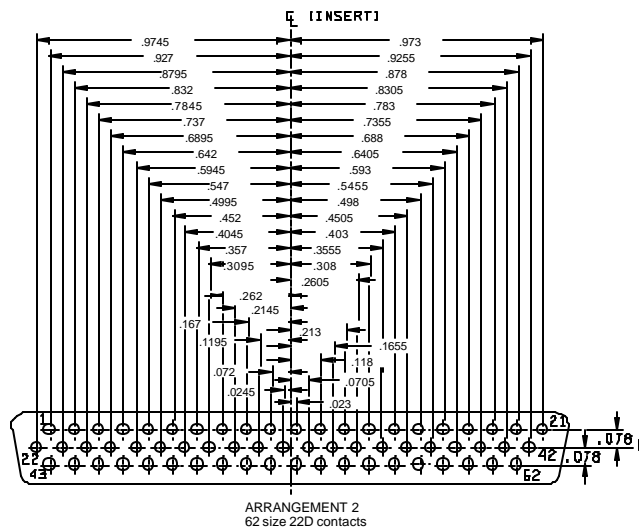

Figure A4, Arrangement 2, delete and substitute:



Figures B-3, B-4, B-5, and B-6, delete and substitute:

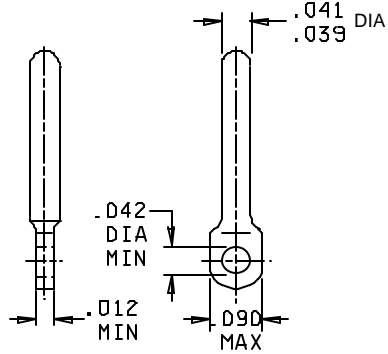

FIGURE B-3. Pin, size 20 eyelet for connector class H.

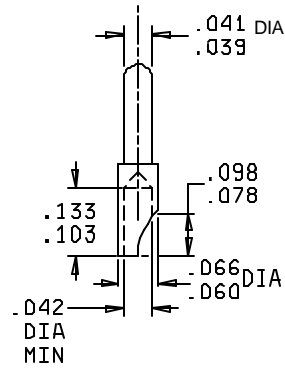

FIGURE B-4. Pin, size 20 solder cup for connector class H.

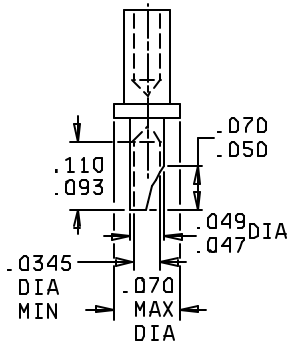

FIGURE B-5. Socket, size 22D (solder cup) for connector classes G and N.

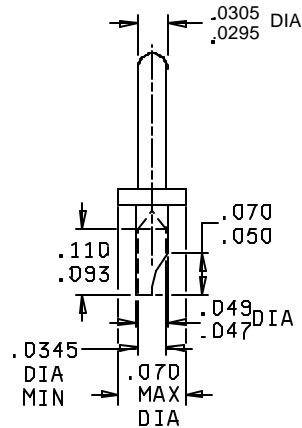

FIGURE B-6. Pin, size 22D (solder cup) for connector classes G and N.

CONCLUDING MATERIAL

Custodians:

- Army - CR
- Navy - EC
- Air Force - 11
- NASA - NA
- DLA - CC

Preparing activity:

- DLA - CC
- (Project 5935-4317)

Review activities:

- Army - AT, CR4, MI
- Navy - AS, CG, MC, SH
- Air Force - 99