

**IPC/ECA J-STD-002C
w/Amendment 1
NOVEMBER 2008
Supersedes J-STD-002C
December 2007**

JOINT INDUSTRY STANDARD

Solderability Tests for
Component Leads,
Terminations, Lugs,
Terminals and Wires



Notice

IPC and ECA Standards and Publications are designed to serve the public interest through eliminating misunderstandings between manufacturers and purchasers, facilitating interchangeability and improvement of products, and assisting the purchaser in selecting and obtaining, with minimum delay, the proper product for his particular need. Existence of such Standards and Publications shall not in any respect preclude any member or nonmember of IPC or ECA from manufacturing or selling products not conforming to such Standards and Publications, nor shall the existence of such Standards and Publications preclude their voluntary use by those other than IPC or ECA members, whether the standard is to be used either domestically or internationally.

Recommended Standards and Publications are adopted by IPC or ECA without regard to whether their adoption may involve patents on articles, materials, or processes. By such action, IPC or ECA do not assume any liability to any patent owner, nor do they assume any obligation whatever to parties adopting the Recommended Standard or Publication. Users are also wholly responsible for protecting themselves against all claims of liabilities for patent infringement. The material in this joint standard was developed by the IPC Component and Wire Solderability Specification Task Group (5-23b) and the ECA Soldering Technology Committee (STC).

For Technical Information Contact:

ECA
2500 Wilson Boulevard
Arlington, VA 22201
Phone (703) 907-8024
Fax (703) 875-8908

IPC
3000 Lakeside Drive, Suite 309S
Bannockburn, IL 60015-1249
Phone (847) 615-7100
Fax (847) 615-7105

Please use the Standard Improvement Form shown at the end of this document.



IPC/ECA J-STD-002C with Amendment 1



Solderability Tests for Component Leads, Terminations, Lugs, Terminals and Wires

A joint standard developed by IPC Component and Wire Solderability Specification Task Group (5-23b) of the Assembly and Joining Processes Committee (5-20) and the Electronic Components, Assemblies and Materials Association (ECA) Soldering Technology Committee (STC)



Supersedes:

J-STD-002C - December 2007
Amendment 1 - October 2008
J-STD-002B - February 2003
J-STD-002A - October 1998
J-STD-002 - April 1992

Users of this publication are encouraged to participate in the development of future revisions.

Contact:

ECA
2500 Wilson Boulevard
Arlington, VA 22201
Phone (703) 907-8024
Fax (703) 875-8908

IPC
3000 Lakeside Drive, Suite 309S
Bannockburn, IL 60015-1249
Phone (847) 615-7100
Fax (847) 615-7105

Acknowledgment

Any document involving a complex technology draws material from a vast number of sources. While the principal members of the IPC Components and Wire Solderability Specification Task Group (5-23b) of the Assembly and Joining Processes Committee (5-20) and the Electronic Components, Assemblies and Materials Association (ECA) Soldering Technology Committee (STC) are shown below, it is not possible to include all of those who assisted in the evolution of this joint industry standard. To each of them, the members and staffs of IPC and ECA Associations extend their gratitude.

IPC Assembly & Joining Processes Committee

Chair
Leo P. Lambert
EPTAC Corporation

Vice Chair
Renee J. Michalkiewicz
Trace Laboratories - East

Component & Wire Solderability Specification Task Group

Chair
David D. Hillman
Rockwell Collins

Vice Chair
Dennis Fritz
MacDermid, Inc.

ECA Soldering Technology Committee

Chair
Douglas W. Romm
Texas Instruments Inc.

IPC Component & Wire Solderability Specification Task Group and ECA Soldering Technology Committee

Dr. Donald Abbott, Sensata Technologies
David C. Adams, Rockwell Collins
Dale Albright, Winslow Automation aka Six Sigma
Greg Alexander, Ascentech, LLC
Francis Anglade, Metronelec
Gail Auyeung, Celestica International Inc.
Chris Ball, Valeo Inc.
Mary Carter Berrios, Kemet Electronics
James D. Bielick, IBM Corporation
Joseph Biernacki, Stackpole Electronics, Inc.
Christine Blair, STMicroelectronics Inc.
Gerald Leslie Bogert, Bechtel Plant Machinery, Inc.
Dr. Edwin Bradley, Motorola Inc.
Jason Bragg, Celestica International Inc.
Dr. Peter Bratin, ECI Technology, Inc.
Michael Cannon, TDK
Dennis Cantwell, Printed Circuits Inc.
Thomas Carroll, Boeing Aircraft & Missiles
Dr. Srinivas Chada, Medtronic Microelectronics Center
Calette Chamness, U.S. Army Aviation & Missile Command

Laya Chen, Microtek (Changzhou) Laboratories
Phillip Chen, L-3 Communications Electronic Systems
Dr. Beverley Christian, Research In Motion Limited
Ted Coler, Vishay Dale
David J. Corbett, Defense Supply Center Columbus
Charles Dal Currier, Ambitech Inc.
Gordon Davy, Best Manufacturing Practices Center of Excellence
Mary Dinh, Northrop Grumman Space Systems Division
Glenn Dody, Dody Consulting
Richard M. Edgar, Tec-Line Inc.
Theodore Edwards, Dynaco Corp.
Robert Furrow, Alcatel-Lucent
Gerald Gagnon, Bose Corporation
Dr. Reza Ghaffarian, Jet Propulsion Laboratory
Andrew Giamis, Andrew Corporation
Jean Gordon, Fairchild Semiconductor
Hue T. Green, Lockheed Martin Space Systems Company
Michael Griffith, KOA Speer Electronics, Inc.
Gerald J. Griswold, Texas Instruments, Inc.
Dr. Carol A. Handwerker, Purdue University

Shirley He, CEPREI
Steven A. Herrberg, Raytheon Systems Company
Dr. Christopher Hunt, National Physical Laboratory
Prakash Kapadia, Celestica International Inc.
Dr. Christian Klein, Robert Bosch GmbH
Connie M. Korth, Kimball Electronics Group
Richard E. Kraszewski, Kimball Electronics Group
Vijay Kumar, Lockheed Martin Missile & Fire Control
Mark A. Kwoka, Intersil Corporation
Patrick Kyne, Defense Supply Center Columbus
Harjinder Ladhar, Solectron Corporation
Leo P. Lambert, EPTAC Corporation
Michael Lauri, IBM
Carl Lindquist, SOC America, Inc.
Laird Macomber, Cornel Dubilier Electronics
James F. Maguire, Intel Corporation
Karun Malhotra, Murata Electronics
Jack McCullen, Intel Corporation
Len Metzger, Panasonic Industrial Company
Renee J. Michalkiewicz, Trace Laboratories - East

Michael Milbrath, BH Electronics	Jim R. Reed, Dell Inc.	David Toomey, Vishay Sprague
Dr. Kil-Won Moon, NIST	Chris Reynolds, AVX Corporation	Sanford
David E. Moore, Defense Supply Center Columbus	David Richardson, Vishay	William Lee Vroom, Thomson Consumer Electronics
Terry L. Munson, Foresite, Inc.	John H. Rohlfing, Delphi Electronics and Safety	Karl F. Wengenroth, Enthone Inc. - Cookson Electronics
Suzanne F. Nachbor, Honeywell Aerospace Minneapolis	William R. Russell, Raytheon Professional Services LLC	George Wenger, Andrew Corporation
Graham Naisbitt, Gen3 Systems Limited	David F. Scheiner, Kester	Robert Wettermann, BEST Inc.
Gary Nicholls, Enthone Inc. - Cookson Electronics	Jeff Seekatz, Raytheon Company	Vicka White, Honeywell Inc.
Benny Nilsson, Ericsson AB	William Sepp, Technic Inc.	Keith Whitlaw, Consultant
Debora L. Obitz, Trace Laboratories - East	Joseph L. Sherfick, NSWC Crane	Maureen Williams, NIST
Gerard A. O'Brien, Solderability Testing & Solutions, Inc.	Lowell Sherman, Defense Supply Center Columbus	Russell T. Winslow, Winslow Automation aka Six Sigma
Stephen Olster, Mini-Systems, Inc.	Bradley Smith, Allegro MicroSystems Inc.	Jere Wittig, HFK Precision Metal Stamping Corporation
Michael Paddack, Boeing Company	Paco Solis, Foresite, Inc.	Linda Woody, Lockheed Martin Missile & Fire Control
Dr. J. Lee Parker, JLP	Roger Su, L-3 Communications	Yung-Herng Yau, Enthone Inc. - Cookson Electronics
Mel Parrish, STI Electronics	Fujiang Sun, Huawei Technologies Co., Ltd.	Jason Young, Kemet Electronics Corporation
Bihari Patel, MacDermid, Inc.	Keith Sweatman, Nihon Superior Co., Ltd.	Michael W. Yuen, Microsoft Corporation
Michael Pavlov, ECI Technology, Inc.	Michael Toben, Rohm and Haas Electronic Materials	Dr. Adam Zbrzezny, AMD
John W. Porter, Multicore Solders Ltd.	Dr. Brian J. Toleno, Henkel Corporation	
John M. Radman, Trace Laboratories - East		

Table of Contents

1 SCOPE	1	4 TEST PROCEDURES	6
1.1 Scope	1	4.1 Application of Flux	6
1.2 Purpose	1	4.2 Visual Acceptance Criteria Tests	8
1.2.1 Shall and Should	1	4.2.1 Test A – Tin/Lead Solder – Solder Bath/Dip and Look Test (Leads, Wires, etc.)	8
1.2.2 Document Hierarchy	1	4.2.1.1 Apparatus	8
1.3 Method Classification	1	4.2.1.1.1 Solder Pot/Bath	8
1.3.1 Visual Acceptance Criteria Tests	1	4.2.1.1.2 Dipping Device	8
1.3.2 Force Measurement Tests	1	4.2.1.2 Preparation	8
1.4 Coating Durability	2	4.2.1.3 Procedure	8
1.5 Referee Verification Solder Dip for Tests A, B, C, A1, B1, C1	2	4.2.1.4 Evaluation	8
1.6 Limitations	2	4.2.1.4.1 Magnification	8
1.7 Contractual Agreement	2	4.2.1.4.2 Accept/Reject Criteria	9
2 APPLICABLE DOCUMENTS	2	4.2.2 Test B – Tin/Lead Solder – Solder Bath/Dip and Look Test (Leadless Components)	10
2.1 Industry	2	4.2.2.1 Apparatus	10
2.1.1 IPC	2	4.2.2.1.1 Solder Pot/Bath	10
2.1.2 International Electrotechnical Commission	2	4.2.2.1.2 Vertical Dipping Device	10
2.2 Government	2	4.2.2.2 Preparation	10
2.2.1 Federal	2	4.2.2.3 Procedure	10
3 REQUIREMENTS	2	4.2.2.4 Evaluation	10
3.1 Terms and Definitions	2	4.2.2.4.1 Magnification	10
3.2 Materials	3	4.2.2.4.2 Accept/Reject Criteria	10
3.2.1 Solder	3	4.2.3 Test C – Tin/Lead Solder – Wrapped Wires Test (Lugs, Tabs, Terminals, Large Stranded Wires)	11
3.2.2 Flux	3	4.2.3.1 Apparatus	11
3.2.2.1 Flux Maintenance	3	4.2.3.1.1 Solder Pot/Bath	11
3.2.3 Flux Removal	3	4.2.3.1.2 Dipping Device	11
3.2.4 Standard Copper Wrapping Wires	3	4.2.3.2 Preparation	11
3.2.5 Water	4	4.2.3.3 Procedure	11
3.3 Equipment	4	4.2.3.4 Evaluation	12
3.3.1 Steam Conditioning Apparatus	4	4.2.3.4.1 Magnification	12
3.3.2 Solder Vessel	4	4.2.3.4.2 Accept/Reject Criteria	12
3.3.3 Optical Inspection Equipment	4	4.2.4 Test D – Tin/Lead or Lead-Free Solder – Resis- tance to Dissolution of Metallization Test	13
3.3.3.1 Referee Magnification	5	4.2.4.1 Apparatus	13
3.3.4 Dipping Equipment	5	4.2.4.1.1 Solder Pot/Bath	13
3.3.5 Timing Equipment	5	4.2.4.1.2 Dipping Device	13
3.4 Preparation for Testing	5	4.2.4.1.3 Attitude (Angle of Immersion)	13
3.4.1 Specimen Preparation and Surface Condition	5	4.2.4.2 Preparation	13
3.4.1.1 Steam Conditioning Categories	5	4.2.4.3 Procedure	13
3.4.2 Steam Conditioning	5	4.2.4.4 Evaluation	13
3.4.2.1 Post Conditioning Drying	6	4.2.4.4.1 Magnification	13
3.4.2.2 Equipment Maintenance	6	4.2.4.4.2 Accept/Reject Criteria	13
3.4.3 Surfaces to be Tested	6	4.2.5 Test S – Tin/Lead Solder – Surface Mount Process Simulation Test	14
3.5 Solder Bath Requirements	6	4.2.5.1 Apparatus	14
3.5.1 Solder Temperatures	6		
3.5.2 Solder Contamination Control	6		

4.2.5.1.1 Stencil/Screen	14	4.2.9.4.1 Magnification	18
4.2.5.1.2 Paste Application Tool	14	4.2.9.4.2 Accept/Reject Criteria	18
4.2.5.1.3 Test Substrate	14	4.3 Force Measurement Tests	19
4.2.5.1.4 Tin/lead Reflow Equipment	14	4.3.1 Test E – Tin/Lead Solder – Wetting Balance Solder Pot Test (Leaded Components)	19
4.2.5.2 Preparation	14	4.3.1.1 Apparatus	19
4.2.5.3 Procedure	14	4.3.1.1.1 Dipping Device	19
4.2.5.4 Evaluation	14	4.3.1.2 Preparation	19
4.2.5.4.1 Magnification	14	4.3.1.3 Procedure	19
4.2.5.4.2 Accept/Reject Criteria	14	4.3.1.4 Evaluation	19
4.2.6 Test A1 – Lead-free Solder – Solder Bath/Dip and Look Test (Leads, Wires, etc.)	15	4.3.1.4.1 Magnification	19
4.2.6.1 Apparatus	15	4.3.1.4.2 Accept/Reject Criteria	19
4.2.6.1.1 Solder Pot/Bath	15	4.3.1.4.3 Gauge Repeatability and Reproducibility (GR&R) Protocol	19
4.2.6.1.2 Dipping Device	15	4.3.2 Test F – Tin/Lead Solder – Wetting Balance Solder Pot Test (Leadless Components)	22
4.2.6.2 Preparation	15	4.3.2.1 Apparatus	22
4.2.6.3 Procedure	15	4.3.2.1.1 Dipping Device	22
4.2.6.4 Evaluation	15	4.3.2.2 Preparation	22
4.2.6.4.1 Magnification	15	4.3.2.3 Procedure	22
4.2.6.4.2 Accept/Reject Criteria	15	4.3.2.4 Evaluation	22
4.2.7 Test B1 – Lead-free Solder – Solder Bath/Dip and Look Test (Leadless Components)	16	4.3.2.4.1 Magnification	22
4.2.7.1 Apparatus	16	4.3.2.4.2 Accept/Reject Criteria	22
4.2.7.1.1 Solder Pot/Bath	16	4.3.2.4.3 Gauge Repeatability and Reproducibility (GR&R) Protocol	22
4.2.7.1.2 Vertical Dipping Device	16	4.3.3 Test G – Tin/Lead Solder – Wetting Balance Globule Test	23
4.2.7.2 Preparation	16	4.3.3.1 Apparatus	23
4.2.7.3 Procedure	16	4.3.3.1.1 Dipping Device	23
4.2.7.4 Evaluation	16	4.3.3.2 Materials	23
4.2.7.4.1 Magnification	16	4.3.3.2.1 Flux	23
4.2.7.4.2 Accept/Reject Criteria	16	4.3.3.2.2 Solder	23
4.2.8 Test C1 – Lead-free Solder – Wrapped Wires Test (Lugs, Tabs, Terminals, Large Stranded Wires)	17	4.3.3.2.3 Test Specimen	23
4.2.8.1 Apparatus	17	4.3.3.3 Procedure	23
4.2.8.1.1 Solder Pot/Bath	17	4.3.3.3.1 Temperature of the Solder	23
4.2.8.1.2 Dipping Device	17	4.3.3.3.2 Fluxing	23
4.2.8.2 Preparation	17	4.3.3.3.3 Dipping Angle, Immersion Depth, and Immersion Rates	23
4.2.8.3 Procedure	17	4.3.3.3.4 Preheat	23
4.2.8.4 Evaluation	17	4.3.3.4 Evaluation	23
4.2.8.4.1 Magnification	17	4.3.3.4.1 Magnification	23
4.2.8.4.2 Accept/Reject Criteria	17	4.3.3.4.2 Suggested Criteria	23
4.2.9 Test S1 – Lead-free Solder – Surface Mount Process Simulation Test	18	4.3.4 Test E1 – Lead-free Solder – Wetting Balance Solder Pot Test (Leaded Components)	26
4.2.9.1 Apparatus	18	4.3.4.1 Apparatus	26
4.2.9.1.1 Stencil/Screen	18	4.3.4.1.1 Dipping Device	26
4.2.9.1.2 Paste Application Tool	18	4.3.4.2 Preparation	26
4.2.9.1.3 Test Substrate	18	4.3.4.3 Procedure	26
4.2.9.1.4 Lead-Free Reflow Equipment	18	4.3.4.4 Evaluation	26
4.2.9.2 Preparation	18	4.3.4.4.1 Magnification	26
4.2.9.3 Procedure	18	4.3.4.4.2 Accept/Reject Criteria	26
4.2.9.4 Evaluation	18		

4.3.4.4.3 Gauge Repeatability and Reproducibility (GR&R) Protocol	26	Figure 4-3 Solder Dipping Depth for Through-Hole Components	9
4.3.5 Test F1 – Lead-free Solder – Wetting Balance Solder Pot Test (Leadless Components)	27	Figure 4-4 Leadless Component Immersion Depth	10
4.3.5.1 Apparatus	27	Figure 4-5 Illustration of Acceptable Solderable Terminal	11
4.3.5.1.1 Dipping Device	27	Figure 4-6 Illustration of Unsolderable Terminal	11
4.3.5.2 Preparation	27	Figure 4-7 Illustration of Acceptable Solderable Stranded Wire	11
4.3.5.3 Procedure	27	Figure 4-8 Illustration of Partially Solderable Stranded Wire Showing Incomplete Fillet	12
4.3.5.4 Evaluation	27	Figure 4-9 Wetting Balance Apparatus	19
4.3.5.4.1 Magnification	27	Figure 4-10 Set A Wetting Curve	20
4.3.5.4.2 Accept/Reject Criteria	27	Figure 4-11 Set B Wetting Curve	21
4.3.5.4.3 Gauge Repeatability and Reproducibility (GR&R) Protocol	27	Figure 4-12 Component and Dipping Angle (Directly from IEC 60068-2-69)	25
4.3.6 Test G1 – Lead-free Solder – Wetting Balance Globule Test	28	Figure A-1 “J” Leaded Components	30
4.3.6.1 Apparatus	28	Figure A-2 Passive Components	31
4.3.6.1.1 Dipping Device	28	Figure A-3 Gull Wing Components	32
4.3.6.2 Materials	28	Figure A-4 Leadless Chip Carrier	33
4.3.6.2.1 Flux	28	Figure A-5 “L” Leaded Components	34
4.3.6.2.2 Solder	28	Figure A-6 Through-Hole Components – Flat Pin	35
4.3.6.2.3 Test Specimen	28	Figure A-7 Through-Hole Components – Round Pin	36
4.3.6.3 Procedure	28	Figure A-8 Exposed Pad Package	37
4.3.6.3.1 Temperature of the Solder	28	Figure A-9 Bottom-Only Termination Component	37
4.3.6.3.2 Fluxing	28	Figure A-10 Area Array Component Critical Surface	38
4.3.6.3.3 Dipping Angle, Immersion Depth, and Immersion Rates	28	Figure B-1 Defect Size Aid	39
4.3.6.3.4 Preheat	28	Figure B-2 Types of Solderability Defects	40
4.3.6.4 Evaluation	28	Figure B-3 Aids in Evaluation of 5% Allowable Area of Pin Holes	41
4.3.6.4.1 Magnification	28	Figure B-4 Aid in Evaluation of 5% Allowable Area of Pin Holes	42
4.3.6.4.2 Suggested Criteria	28	Figure B-5 Solderability Coverage Guide	43
5 NOTES	29	Figure C-1 Lead Periphery and Volume for a 132 I/O PQFP	45
5.1 Use of Activated Flux	29		
5.2 Massive Components	29		
5.3 Sampling Plans	29		
5.4 Safety Notes	29		
5.5 Correction for Buoyancy	29		
5.6 Accelerated Steam Conditioning Limitations	29		
Appendix A	30		
Appendix B	39		
Appendix C	44		
Appendix D	46		
Appendix E	47		
Appendix F	48		
Appendix G	50		
Appendix H	53		
Figures		Tables	
Figure 3-1 Example Reticle	4	Table 1-1 Steam Conditioning Categories for Component Leads and Terminations	2
Figure 4-1 Dipping Schematic	8	Table 3-1 Flux Compositions	3
Figure 4-2 Solder Dipping Angle for Surface Mount Leaded Components	9	Table 3-2 Steam Temperature Requirements	4
		Table 3-3 Solderability Test Selection Component Type	5
		Table 3-4 Maximum Limits of Solder Bath Contaminant ..	6
		Table 4-1 Stencil Thickness Requirements	14
		Table 4-2 Reflow Parameter Requirements	14
		Table 4-3 Stencil Thickness Requirements	18
		Table 4-4 Lead-free Reflow Parameter Requirements	18
		Table 4-5 Wetting Balance Parameter and Suggested Evaluation Criteria	20
		Table 4-6 Dipping Angle and Immersion Depth for Components (Directly from IEC 60068-2-69) ..	24
		Table 4-7 Wetting Parameters and Suggested Evaluation Criteria	25
		Table 3-1 Flux Compositions	48

Solderability Tests for Component Leads, Terminations, Lugs, Terminals and Wires

1 SCOPE

1.1 Scope This standard prescribes test methods, defect definitions, acceptance criteria, and illustrations for assessing the solderability of electronic component leads, terminations, solid wires, stranded wires, lugs, and tabs. This standard also includes a test method for the Resistance to Dissolution/Dewetting of Metallization. This standard is intended for use by both vendor and user.

1.2 Purpose Solderability evaluations are made to verify that the solderability of component leads and terminations meets the requirements established in this standard and to determine that storage has had no adverse effect on the ability to solder components to an interconnecting substrate. Determination of solderability can be made at the time of manufacture, at receipt of the components by the user, or just before assembly and soldering.

The resistance to dissolution of metallization determination is made to verify that metallized terminations will remain intact throughout the assembly soldering processes.

1.2.1 Shall and Should The word “shall” is used in the text of this document wherever there is a requirement for materials, preparation, process control or acceptance of a soldered connection or a test method. The word “should” reflects recommendations and is used to reflect general industry practices and procedures for guidance only.

1.2.2 Document Hierarchy In the event of conflict, the following decreasing order of precedence applies:

1. Procurement as agreed between user and supplier.
2. Master drawing or master assembly drawing reflecting the user’s detailed requirements.
3. When invoked by the customer or per contractual agreement, this document, J-STD-002.
4. Other documents to extent specified by the customer.

1.3 Method Classification This standard describes methods by which component leads or terminations may be evaluated for solderability. Test A, Test B, Test C, Test D and Test S for tin/lead solder processes and Test A1, Test B1, Test C1, Test D and Test S1 for lead-free solder processes, unless otherwise agreed upon between vendor and user, are to be used for each application as a default.

1.3.1 Visual Acceptance Criteria Tests

Test A – Solder Bath/Dip and Look Test (Leaded Components and Stranded Wires) Tin/Lead Solder (paragraph 4.2.1)

Test B – Solder Bath/Dip and Look Test (Leadless Components) Tin/Lead Solder (paragraph 4.2.2)

Test C – Wrapped Wires Test (Lugs, Tabs, Hooked Leads, and Turrets) Tin/Lead Solder (paragraph 4.2.3)

Test D – Resistance to Dissolution/Dewetting of Metallization Test Tin/Lead Solder and Lead-free Solder (paragraph 4.2.4)

Test S – Surface Mount Process Simulation Test Tin/Lead Solder (paragraph 4.2.5)

Test A1 – Solder Bath/Dip and Look Test (Leaded Components and Stranded Wires) Lead-free Solder (paragraph 4.2.6)

Test B1 – Solder Bath/Dip and Look Test (Leadless Components) Lead-free Solder (paragraph 4.2.7)

Test C1 – Wrapped Wires Test (Lugs, Tabs, Hooked Leads, and Turrets) Lead-free Solder (paragraph 4.2.8)

Test S1 – Surface Mount Process Simulation Test Lead-free Solder (paragraph 4.2.9)

1.3.2 Force Measurement Tests

Test E – Wetting Balance Solder Pot Test (Leaded Components) Tin/Lead Solder (paragraph 4.3.1)

Test F – Wetting Balance Solder Pot Test (Leadless Components) Tin/Lead Solder (paragraph 4.3.2)

Test G – Wetting Balance Globule Test Tin/Lead Solder (paragraph 4.3.3)

Test E1 – Wetting Balance Solder Pot Test (Leaded Components) Lead-free Solder (paragraph 4.3.4)

Test F1 – Wetting Balance Solder Pot Test (Leadless Components) Lead-free Solder (paragraph 4.3.5)

Test G1 – Wetting Balance Globule Test Lead-free Solder (paragraph 4.3.6)

These methods (1.3.2) are included for evaluation purposes only. Data collected should be submitted to the IPC Wetting Balance Task Group for correlation and analysis. Tests E, F, G, E1, F1 and G1 **shall not** be used for acceptance/rejection without user and vendor agreement.

1.4 Coating Durability The following are guidelines, not specification requirements, for determining the needed level of steam conditioning category assurance (see Table 1–1). The Coating Durability guidelines describe three broad usage sectors and are not intended to encompass all possible product use scenarios. The user and vendor need to agree on the coating durability requirements. Coating Durability Category 3 is the default condition for tin-based finishes.

Category 1 — Minimum Coating Durability Intended for surfaces that will be soldered within a short period of time (e.g., up to six months) from the time of testing and are likely to experience a minimum of thermal exposures before soldering (see 5.6).

Category 2 — Typical Coating Durability Intended for surfaces that will be soldered after an extended time from the time of testing and which may see limited thermal exposures before soldering (see 5.6).

Category 3 — Enhanced Coating Durability (default for tin-based finishes) Intended for surfaces whose solderability may become degraded from storage of longer than six months or from multiple thermal exposures (see 5.6).

Table 1–1 Steam Conditioning Categories for Component Leads and Terminations

Category 1	Category 2	Category 3
No Steam Conditioning Requirements	1 Hour ± 5 min. Steam Conditioning	8 hours ± 15 min. Steam Conditioning

1.5 Referee Verification Solder Dip for Tests A, B, C, A1, B1, C1 When the dipped portion of the termination exhibits anomalies such as surface roughness, or dross, or anomalies that may have been induced by improper solder dipping, a referee verification solder dip of the suspect anomaly may be necessary. Upon reinspection, if the suspect anomaly has been removed, the anomaly will have been verified as a non-rejectable cosmetic surface defect. If the anomaly persists, regardless of area, it **shall** be classified a rejectable solderability defect. This procedure may only be used on one component per lot. Continuous need of Referee Verification Solder Dip procedure is an indication of either improper testing procedure, examination interpretation, or of poor component quality.

1.6 Limitations This standard **shall not** be construed as a production procedure for the pre-tinning of leads and terminations. Solderability testing of components is considered a destructive test and the tested component should not be used for functional electrical evaluation. Components after such solderability testing, **shall** only be used with agreement between the user and supplier (AABUS).

1.7 Contractual Agreement In cases where the stated test parameters are inappropriate or insufficient, alternative parameters may be agreed upon between vendor and user.

2 APPLICABLE DOCUMENTS

The following documents of the issue currently in effect form a part of this standard to the extent specified herein.

2.1 Industry

2.1.1 IPC¹

IPC-T-50 Terms and Definitions

IPC-TR-464 Accelerated Aging for Solderability Evaluations and Addendum

J-STD-004 Requirements For Soldering Fluxes

J-STD-005 Requirements for Soldering Pastes

J-STD-006 Requirements for Electronic Grade Solder Alloys and Fluxed and Non-Fluxed Solid Solder for Electronic Soldering Applications

IPC-TM-650 Test Methods Manual

2.1.2 International Electrotechnical Commission²

IEC 60068–2-69 Environmental testing – Part 2–69: Tests – Test Te: Solderability testing of electronic components for surface mounting devices (SMD) by the wetting balance method

2.2 Government

2.2.1 Federal

(CID) A-A-59551 Wires, Electrical, Copper (Uninsulated)

3 REQUIREMENTS

3.1 Terms and Definitions The definition of terms **shall** be in accordance with IPC-T-50. Terms repeated from IPC-T-50 are indicated by an asterisk (*).

*Dewetting** A condition that results when molten solder coats a surface and then recedes to leave irregularly-shaped mounds of solder that are separated by areas that are covered with a thin film of solder and with the basis metal not exposed.

1. www.ipc.org

2. www.iec.ch

Dissolution of Component Metallization (Leaching) The loss or removal of metallization from an area on the basis or substrate material after immersion in molten solder.

Equilibrium Wetting The degree of wetting in which the forces of wetting are in equilibrium with the forces of gravity.

Note: This wetting is visible when the wetting balance curve flattens out and approaches zero slope (see Figure 4–10).

*Nonwetting, Solder** The partial adherence of molten solder to a surface that it has contacted while leaving some basis metal exposed.

*Pinhole** An imperfection in the form of a small hole that penetrates through a layer of material.

*Solderability** The ability of a metal to be wetted by molten solder.

*Solder Connection Pinhole** A small hole that penetrates from the surface of a solder connection to a void of indeterminate size within the solder connection.

*Wetting, Solder** The formation of a relatively uniform, smooth, unbroken, and adherent film of solder to a basis metal.

3.2 Materials All chemicals **shall** be of commercial grade or better. Fresh solvents **shall** be used as often as is necessary to preclude contamination.

3.2.1 Solder For tin/lead testing, the solder composition **shall** be Sn60Pb40 or Sn63Pb37 per J-STD-006. The composition of the solder, including contamination levels, **shall** be maintained during testing per 3.5.2.

The composition of the tin/lead solder paste to be used in Test S **shall** be Sn60Pb40 or Sn63Pb37 for tin/lead per J-STD-005, mesh size of -325/+500, flux type ROL1. The solder paste **shall** meet the storage and shelf life requirements of the manufacturer's specification. The user's specific production solder paste product may be used for Test S upon agreement between user and supplier.

For lead-free testing, the solder composition **shall** be Sn96.5Ag3.0Cu0.5 (SAC305) per J-STD-006. Other lead-free solder alloys may be used upon agreement between user and vendor.

The composition of the lead-free solder paste to be used in Test S1 **shall** be Sn96.5Ag3.0Cu0.5 (SAC305) per J-STD-005, mesh size of -325/+500, flux type to be agreed upon between user and vendor. The solder paste **shall** meet the storage and shelf life requirements of the manufacturer's specification. Other lead-free solder pastes may be used upon agreement between user and vendor.

The user's specific production solder paste product may be used for Test S1 upon agreement between user and supplier.

3.2.2 Flux The flux for tin/lead solderability tests **shall** be a standard activated rosin flux #1 having a composition of 25% \pm 0.5% by weight of colophony and 0.15% \pm 0.01% by weight diethylammonium hydrochloride (CAS 660-68-4), in 74.85% \pm 0.5% by weight of isopropyl alcohol (see Table 3–1).

The flux for lead-free solderability tests **shall** be standard activated rosin flux #2 having a composition of 25% \pm 0.5% by weight of colophony and 0.39% \pm 0.01% by weight diethylammonium hydrochloride (CAS 660-68-4), in 74.61% \pm 0.5% by weight of isopropyl alcohol (see Table 3–1).

Table 3–1 Flux Compositions

Constituent	Composition by Weight Percent	
	Flux #1	Flux #2
Colophony	25 \pm 0.5	25 \pm 0.5
Diethylammonium Hydrochloride (CAS 660-68-4)	0.15 \pm 0.01	0.39 \pm 0.01
Isopropyl Alcohol (IPA) (CAS 67-63-0)	Balance	Balance
Weight of Chlorine as % of Solids	0.2	0.5

Appendix E: Informative Annex contains a listing of industry test flux product sources.

The flux to be used in preparing the standard copper wrapping wires (see 3.2.4) for tests C and C1 **shall** conform to J-STD-004, Type ROL1. This flux **shall** be restricted to the preparation of the standard wrapping wires and **shall not** be used in performing the solderability tests for any of the methods herein.

3.2.2.1 Flux Maintenance Standard activated rosin fluxes #1 and #2 **shall** be covered when not in use and discarded after eight hours or the flux **shall** be maintained to a specific gravity of 0.843 \pm 0.005 at 25 \pm 2°C [77 \pm 3.6°F] and discarded after one week of use.

3.2.3 Flux Removal Material used for cleaning flux from leads and terminations before solderability evaluations **shall** be capable of removing visible flux residues (see 5.4). The cleaned surface **shall** exhibit no mechanical damage.

3.2.4 Standard Copper Wrapping Wires The standard wrapping wires specified in 4.2.3.2 **shall** be fabricated from type S, soft or drawn and annealed, uncoated in accordance with (CID) A-A-59551 and prepared per the following process.

The nominal diameter of the wrapping wires shall be 0.6 mm [0.023 in]. The preparation of the wrapping wires shall be as follows:

- a. Straighten and cut wires into convenient lengths (50 mm [1.9 in] minimum).
- b. Degrease by immersion in an appropriate cleaner (e.g., isopropyl alcohol) for two minutes.
- c. Clean in fluoroboric acid 10% HBF₄ (by volume), in water, for five minutes at room temperature with agitation. Use caution in handling.
- d. Rinse acid off as follows:
 1. Two nonheated water rinses (deionized or distilled).
 2. Two isopropyl alcohol rinses.
 3. Air dry.
- e. Immerse in flux J-STD-004, Type ROL1.
- f. Dip in molten solder for five seconds at 245 ± 5°C [473 ± 9°F] for tin/lead solder alloy. Dip in molten solder for five seconds at 255 ± 5°C [491 ± 9°F] for lead-free solder alloy.

To remove or dissolve the residual flux, wash or rinse per 3.2.3.

Standard wrapping wires will be stored in a clean, covered container if not used immediately. The usable life of the standard wrapping wires shall not exceed 30 days after coating.

3.2.5 Water The water to be used for steam conditioning purposes shall be distilled or deionized.

3.3 Equipment The following equipment applies to more than one of the solderability test methods shown in this standard. Equipment that is specific to any of the test methods is described in the specific Clause 4 paragraphs detailing the method.

3.3.1 Steam Conditioning Apparatus The steam conditioning chamber shall be constructed of non-corrodible materials such as borosilicate glass, quartz glass, stainless steel or PTFE. The specimen holder shall be non-reactive to prevent galvanic corrosion. The container should be insulated. The steam temperature at the conditioning level shall be maintained per the requirements of Table 3–2.

A safe means to prevent excessive pressure and a means of maintaining adequate water level shall be provided. Neither shall cause the vapor to cool below the specified temperature. Condensate shall drip freely back to the water. Care should be taken to minimize contact between the condensate and the specimens.

3.3.2 Solder Vessel A thermostatically controlled static solder vessel shall be used for all applicable tests. The

Table 3–2 Steam Temperature Requirements

Altitude	Average Local Boiling Point °C	Steam Temperature Limits °C
0–305 m	100	93 ± 3
305–610 m	99	92 ± 3
610–914 m	98	91 ± 3
914–1219 m	97	90 ± 3
1219–1524 m	96	89 ± 3
1524–1829 m	95	88 ± 3

solder vessel shall be of adequate dimensions to accommodate the specimens and contain sufficient solder to maintain the solder temperature during testing, and to prevent exceeding the contamination levels (see 3.5.1 and 3.5.2). A minimum of 750 grams of solder should be used. Note: Precautions should be taken to avoid solder vessel damage due to metal erosion when using Lead-free solder alloys.

3.3.3 Optical Inspection Equipment All test methods requiring visual inspection shall use microscope(s) capable of 10X magnification (see individual test methods), equipped with reticles, or equivalent, for measurement. An example of a reticle is shown in Figure 3–1. Shadowless lighting shall be suitable for proper inspection.

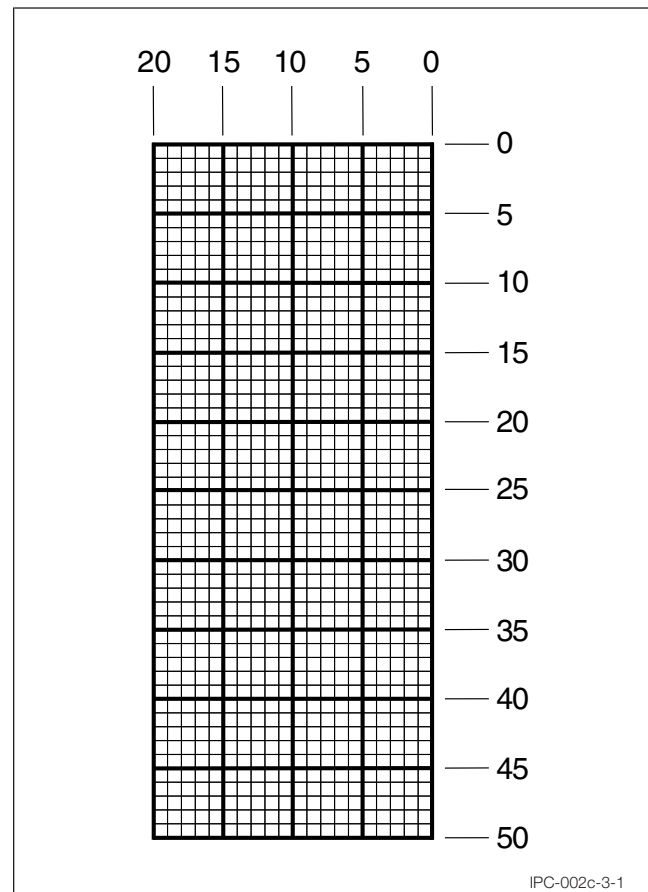

Figure 3–1 Example Reticle

IPC-002c-3-1

3.3.3.1 Referee Magnification Referee magnification **shall** be 30X. For fine pitch leaded parts (0.5 mm [0.020 in] pitch or less) the referee magnification **shall** be 70X. Referee conditions **shall** only be used to accept a product that has been rejected at the inspection magnification.

3.3.4 Dipping Equipment Solder dipping devices **shall** be mechanical/electro-mechanical and capable of controlling the immersion/emersion rates, dwell time and immersion depth as specified in 4.2.1 to 4.2.9. Sample holding fixtures **shall** be designed to avoid trapping any excess flux in the fixture and to minimize heat loss and assure reproducibility of test results.

3.3.5 Timing Equipment Timing equipment **shall** be automated, where applicable, and accurate to the limits of the test method.

3.4 Preparation for Testing

3.4.1 Specimen Preparation and Surface Condition All component leads or terminations **shall** be tested in the condition that they would normally be in at the time of assembly soldering. The specimen surfaces to be tested **shall** be handled in such a manner as to not cause contamination, nor **shall** the leads or terminations being tested be wiped, cleaned, scraped or abraded.

Special preparation of leads or terminations, such as bending or reorientation before test, **shall** be specified in the applicable procurement document. If the insulation on stranded wire must be removed, it **shall** be done in a manner so as not to loosen or damage the individual strands of the wires.

3.4.1.1 Steam Conditioning Categories The user **shall** specify to the vendor, as part of the purchase agreement, the required coating durability (see 1.4). Accelerated steam conditioning **shall** be performed per Table 1–1. Solderability testing **shall** be performed per the appropriate test in Table 3–3.

3.4.2 Steam Conditioning Before the application of flux and subsequent solderability testing, all specimens designated Category 2 and 3 Coating Durability **shall** be conditioned in the device and under the conditions described in 3.3.1 at a steam temperature which is 7°C [12.6°F] below the local boiling point (see Table 3–2).

All components to be tested **shall** be placed into the steam conditioning chamber such that no specimens have their leads or terminations touching, and that condensation forming will drain away from the lead or terminations to the package body, e.g., “Dead Bug” for dual-inline packages.

Table 3–3 Solderability Test Selection Component Type

Test Method	Wrapped Wires	Through-Hole Mount	Surface Mount		
			Leadless	J-Lead	Gull Wing
Visual Acceptance Criteria Tests					
A – Dip & Look Test (Leaded Components) Tin/Lead Solder		X		X	X
A1 – Dip & Look Test (Leaded Components) Lead-free Solder					
B – Dip & Look Test (Leadless Components) Tin/Lead Solder			X		
B1 – Dip & Look Test (Leadless Components) Lead-free Solder					
C – Wrapped Wires Test Tin/Lead Solder	X				
C1 – Wrapped Wires Test Lead-free Solder					
D – Resistance to Dissolution of Metallization Test (Tin/Lead and Lead-free Solder)			X	X	X
S – Surface Mount Process Simulation Test Tin/Lead Solder			X	X	X
S1 – Surface Mount Process Simulation Test Lead-free Solder					
Force Measurement Tests					
E – Wetting Balance Solder Pot Test (Leaded Components) Tin/Lead Solder		X		X	X
E1 – Wetting Balance Solder Pot Test (Leaded Components) Lead-free solder					
F – Wetting Balance Solder Pot Test (Leadless Components) Tin/Lead Solder			X		
F1 – Wetting Balance Solder Pot Test (Leadless Components) Lead-free solder					
G – Wetting Balance Globule Test Tin/Lead Solder			X	X	X
G1 – Wetting Balance Globule Test Lead-free solder					

Specimens **shall not** be stacked in a manner which restricts their surface exposure to steam nor **shall** they be placed closer than 10 mm [0.39 in] from the outer chamber walls, and **shall not** touch the inner container walls. In addition, no portion of the specimen **shall** be less than 40 mm [1.57 in] above the water level.

3.4.2.1 Post Conditioning Drying After steam conditioning is complete, specimens **shall** be immediately removed from the chamber and ambient air dried. Solderability testing **shall** be performed within 72 hours of removal from the chamber.

3.4.2.2 Equipment Maintenance Before use, the steam conditioning apparatus **shall** have been cleaned with deionized or distilled water or hydrogen peroxide to remove any accumulated residues. This cleaning should be accomplished within five working days of the conditioning period.

3.4.3 Surfaces to be Tested The critical areas of leads or terminations intended to be soldered **shall** be evaluated for solderability per the test method (see appendix A). This **shall** include both the bottom termination and castellation on chip carriers and on all surfaces intended to be soldered on discrete devices. Through-hole leads that are tested by Method A **shall** have a 25 mm [0.98 in] portion, or the whole lead if less than 25 mm [0.98 in], evaluated for solderability (see 4.2.1.4). Test methods **shall** be selected per Table 3–3.

Surfaces to be tested by Method D **shall** be completely immersed in molten solder during dipping (see 4.2.4).

3.5 Solder Bath Requirements

3.5.1 Solder Temperatures Tin/lead solderability testing **shall** be done at a solder temperature of $245 \pm 5^\circ\text{C}$ [$473 \pm 9^\circ\text{F}$]. Lead-free solderability testing **shall** be done at a solder temperature of $255 \pm 5^\circ\text{C}$ [$491 \pm 9^\circ\text{F}$]. A temperature of $260 \pm 5^\circ\text{C}$ [$500 \pm 9^\circ\text{F}$] **shall** be used for Test Method D for both tin/lead or lead-free solder alloys.

3.5.2 Solder Contamination Control The solder in solder baths used for solderability testing **shall** be chemically or spectrographically analyzed or replaced each 30 operating days. The levels of contamination and Sn content must be within those shown in Table 3–4. The intervals between analysis may be lengthened if the test results indicate that the contamination limits are not being approached. The composition of the lead-free solder, including contamination levels, **shall** be maintained during testing with the silver and copper element levels adjusted for alloy requirements.

Table 3–4 Maximum Limits of Solder Bath Contaminant

Contaminant	Maximum Contaminant Weight Percentage Limit Sn Pb Alloys ^(1,2)	Maximum Contamination Weight Percentage Limit Lead-free Alloys ^(3,4)
Copper	0.300	1.000
Gold	0.200	0.200
Cadmium	0.005	0.005
Zinc	0.005	0.005
Aluminum	0.006	0.006
Antimony	0.500	0.500
Iron	0.020	0.020
Arsenic	0.030	0.030
Bismuth	0.250	0.250
Silver	0.100	4.000
Nickel	0.010	0.010
Lead	N/A	0.100

Notes:

- The tin content of the solder shall be maintained within $\pm 1\%$ of the nominal alloy being used. Tin content shall be tested at the same frequency as testing for copper/gold contamination. The balance of the bath shall be lead and/or the items listed above.
- The total of copper, gold, cadmium, zinc, and aluminum contaminants **shall not** exceed 0.4%. Not applicable to lead-free alloys.
- The tin content of the solder **shall** be maintained within $\pm 1\%$ of the nominal alloy being used. Tin content **shall** be tested at the same frequency as testing for copper/silver concentration. The balance of the bath **shall** be the items listed above.
- Maximum contamination limits are applicable for Sn96.5Ag3.0Cu0.5 (SAC305) per J-STD-006. Other lead-free solder alloy contamination limits may be used upon agreement between user and vendor.

NOTE: An operating day consists of any eight-hour period, or any portion thereof, during which the solder is liquefied and used.

If contamination exceeds the limits specified in Table 3–4, then the solder **shall** be changed and the intervals between analysis **shall** be shortened. A sampling plan **shall** be developed, implemented, and documented, demonstrating solder contamination limit process control.

4 TEST PROCEDURES

4.1 Application of Flux Flux per 3.2.2 **shall** be used. Leads and terminations **shall** have flux applied uniformly and to cover the surfaces to be tested. The flux **shall** be at room temperature. This section, 4.1, **shall** apply to all of the following tests: A, B, C, D, E, F, G, A1, B1, C1, E1, F1 and G1 but **shall not** apply to both tests S and S1, which require the use of solder paste and not a separate flux.

Axial, radial, and multiple leaded components intended for through-hole mounting **shall** have their leads immersed into the flux approximately perpendicular to the flux surface. Leaded or leadless components intended for surface mounting **shall** have their leads or terminations immersed at an angle between 20° and 45° to the flux

surface. The surfaces to be tested **shall** be immersed in the flux for 5 to 10 seconds. Any droplets of flux that may form **shall** be removed by blotting, taking care not to remove the flux coating from the surfaces to be tested. For small passive surface mount devices, the flux droplets

may be (but are not required to be) blotted from the surface. The specimens being tested **shall** be allowed to dry for 5 to 20 seconds before solder immersion, but **shall not** be allowed to dwell above solder-pot (no preheat) before actual dipping action.

4.2 Visual Acceptance Criteria Tests

4.2.1 Test A – Tin/Lead Solder – Solder Bath/Dip and Look Test (Leads, Wires, etc.) This test is for solder bath/dip and look testing of leaded components, solid wires, and stranded wires greater than 0.254 mm [0.01 in] minimum.

4.2.1.1 Apparatus

4.2.1.1.1 Solder Pot/Bath A solder vessel that meets the requirements of 3.3.2 **shall** be used. The solder **shall** meet the requirements of 3.2.1. Solder bath temperatures and solder contamination control **shall** be in accordance with 3.5.1 and 3.5.2.

4.2.1.1.2 Dipping Device A mechanical or electromechanical dipping device similar to the device shown in Figure 4-1 **shall** be used unless otherwise agreed to between user and vendor. The rate of immersion, dwell time, and rate of withdrawal **shall** be within the test limits defined in 4.2.1.3. Perpendicularity of through-hole component leads to solder surface **shall** be maintained. Leaded surface mount components **shall** be immersed at between 20° and 45° (or 90° if agreed upon) to the solder surface (see Figure 4-2). This angle **shall** remain consistent for any given component type. Wobble, vibration and other extraneous movements **shall** be minimized.

***NOTE:** The solder temperature in the Solder Station as seen in Figure 4-1 **shall** be:

- a) $245 \pm 5^\circ\text{C}$ [$473 \pm 9^\circ\text{F}$] for tin/lead solder testing, or

- b) $255 \pm 5^\circ\text{C}$ [$491 \pm 9^\circ\text{F}$] for lead-free solder testing.

4.2.1.2 Preparation Specimen preparation **shall** be in accordance with 3.4.

4.2.1.3 Procedure

- Dross and burned flux **shall** be skimmed from the surface of the molten solder immediately before dipping.
- The fluxed specimen **shall** be immersed in the molten solder to within 1.27 mm [0.050 in] of the component body or to the seating plane (whichever is further from the component body) for through-hole leaded components (see Figure 4-3).
- Immerse and withdraw at 25 ± 6 mm [0.984 ± 0.24 in] per second and dwell for $5 +0/-0.5$ seconds (see 5.2).
- After withdrawal, the solder **shall** be allowed to solidify by air cooling while the specimen is maintained in the test attitude.
- Before examination, all leads **shall** have all visible flux residues removed per 3.2.3.

4.2.1.4 Evaluation

4.2.1.4.1 Magnification Parts **shall** be examined at 10X using the equipment specified in 3.3.3. For fine pitch leaded parts (0.5 mm [0.020 in] pitch or less) the inspection magnification **shall** be 30X.

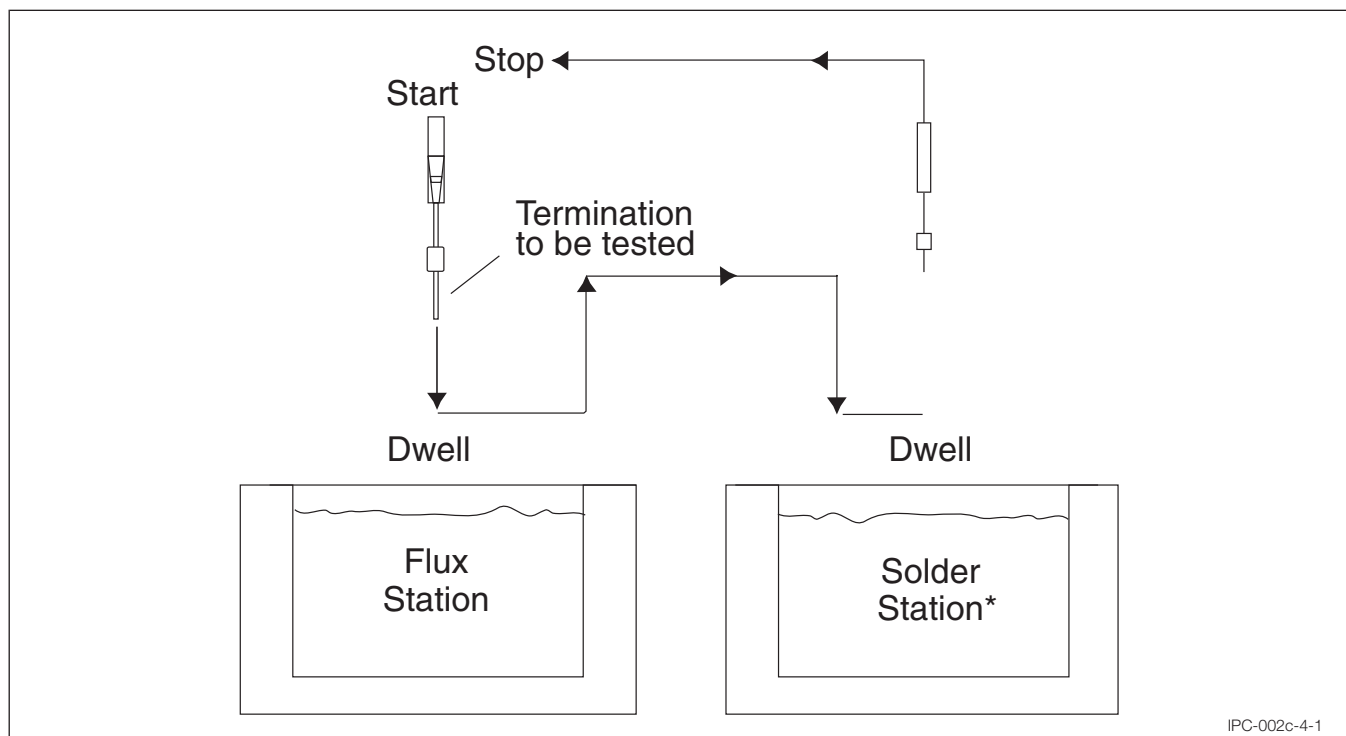

Figure 4-1 Dipping Schematic

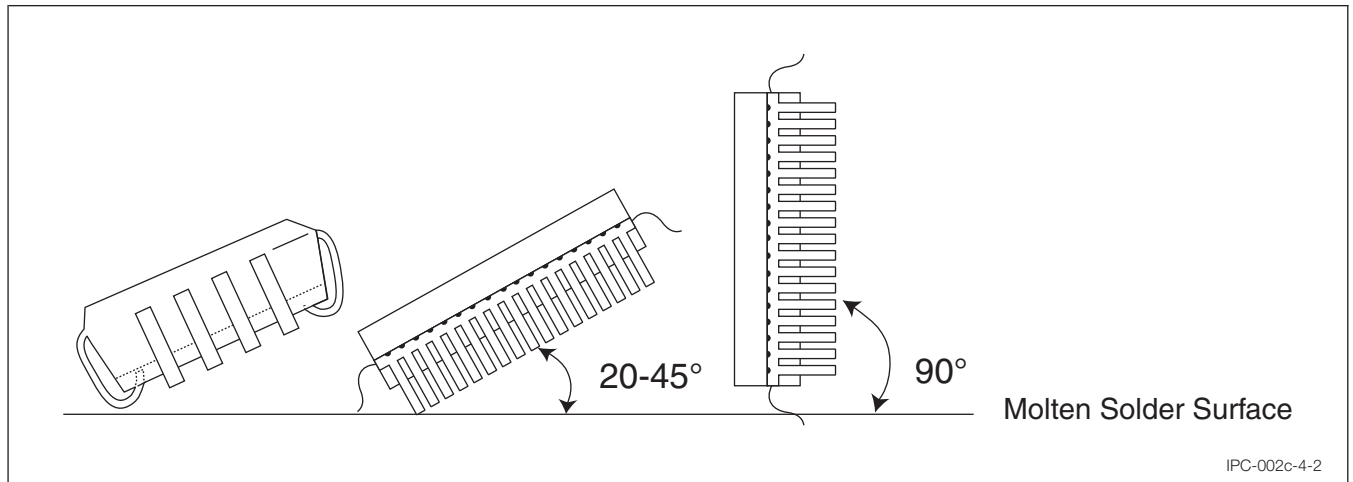

Figure 4-2 Solder Dipping Angle for Surface Mount Ledged Components

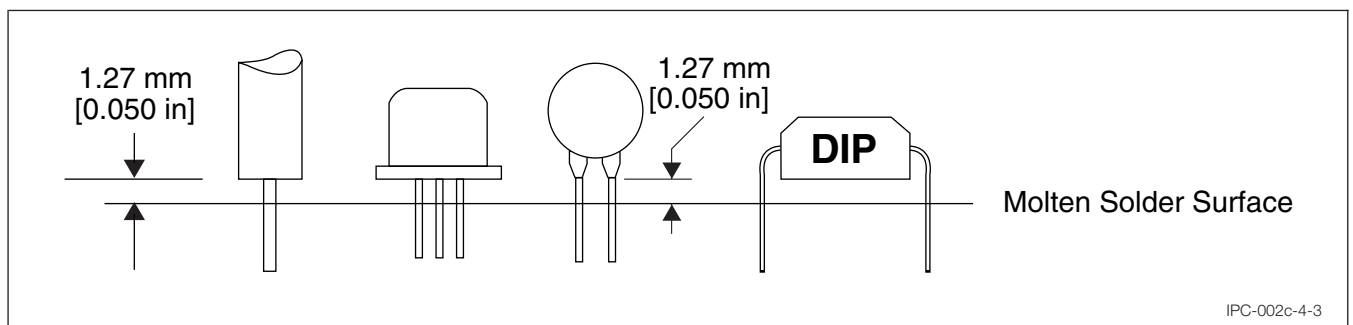

Figure 4-3 Solder Dipping Depth for Through-Hole Components

4.2.1.4.2 Accept/Reject Criteria All leads **shall** exhibit a continuous solder coating free from defects for a minimum of 95% of the critical area of any individual lead. For exposed pad packages the exposed pad surfaces **shall** exhibit a continuous solder coating free from defects for a minimum of 80% of the critical area of those

surfaces. Anomalies other than dewetting, nonwetting, and pin holes are not cause for rejection (see Appendices A and B). Exposed terminal metal is allowable on surface mount components at the toe end and on the vertical surfaces that are either unplated or sheared during component fabrication.

4.2.2 Test B – Tin/Lead Solder – Solder Bath/Dip and Look Test (Leadless Components) This test is for solder bath/dip and look testing of leadless components.

4.2.2.1 Apparatus

4.2.2.1.1 Solder Pot/Bath A solder vessel that meets the requirements of 3.3.2 **shall** be used. The solder **shall** meet the requirements of 3.2.1. Solder bath temperatures and solder contamination control **shall** be in accordance with 3.5.1 and 3.5.2.

4.2.2.1.2 Vertical Dipping Device A mechanical or electro-mechanical dipping device similar to the device shown in Figure 4–1 **shall** be used unless otherwise agreed to between user and vendor. The rate of immersion, dwell time, and rate of withdrawal **shall** be within the test limits defined in 4.2.2.3. Surface mount leadless components **shall** be immersed at an angle to the solder surface of 20°- 45° and 90° for discrete chip components and exposed pad packages. Other immersion angles may be used if agreed upon between vendor and user.

4.2.2.2 Preparation Specimen preparation **shall** be in accordance with 3.4.

4.2.2.3 Procedure

a. Dross and burned flux **shall** be skimmed from the surface of the molten solder immediately before dipping.

- The fluxed specimen **shall** be immersed in the molten solder 0.10 mm [0.0039 in] minimum (see Figure 4–4). Immerse and withdraw at 25 ± 6 mm [0.984 \pm 0.24 in] per second and dwell for 5 +0/-0.5 seconds. Massive components may require a longer molten solder dwell time (see 5.2).
- After withdrawal, the solder **shall** be allowed to solidify by air cooling while the specimen is maintained in the test attitude.
- Before examination, all terminations **shall** have all visible flux residues removed per 3.2.3.

4.2.2.4 Evaluation

4.2.2.4.1 Magnification Parts **shall** be examined at 10X using the equipment specified in 3.3.3. For fine pitch termination parts (0.5 mm [0.020 in] pitch or less) the inspection magnification **shall** be 30X.

4.2.2.4.2 Accept/Reject Criteria All terminations **shall** exhibit a continuous solder coating free from defects for a minimum of 95% of the critical area of any individual termination. For exposed pad packages, the exposed pad surfaces **shall** exhibit a continuous solder coating free from defects for a minimum of 80% of the critical area of those surfaces. Anomalies other than dewetting, nonwetting, and pin holes are not cause for rejection (see Appendices A and B). Exposed terminal metal is allowable on surface mount components at the toe end and on the vertical surfaces that are either unplated or sheared during component fabrication.

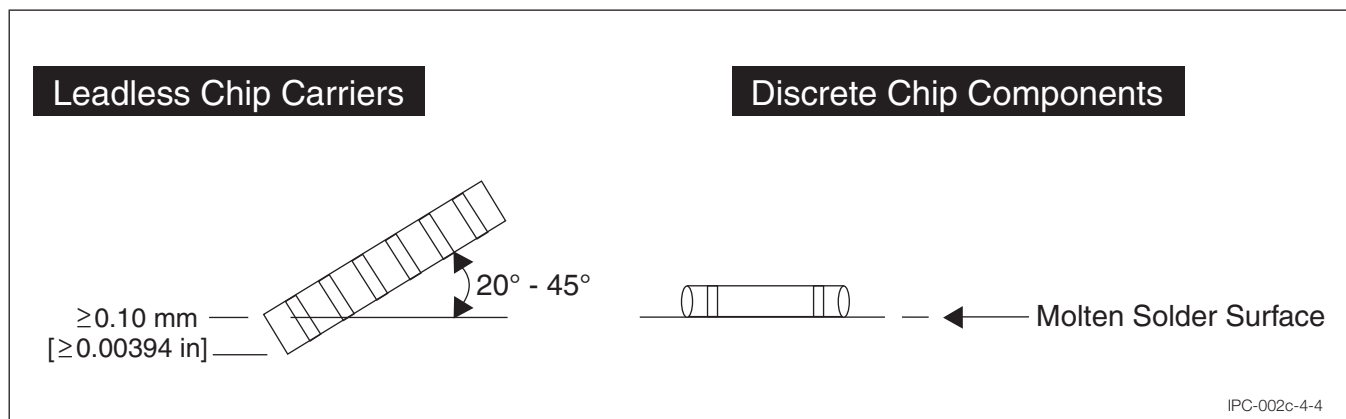

Figure 4–4 Leadless Component Immersion Depth

4.2.3 Test C – Tin/Lead Solder – Wrapped Wires Test (Lugs, Tabs, Terminals, Large Stranded Wires) This test is for wrapped wires testing of lugs, tabs, terminals, stranded wires greater than 1.016 mm [0.040 in] diameter, and solid wires greater than 1.143 mm [0.045 in] diameter.

4.2.3.1 Apparatus

4.2.3.1.1 Solder Pot/Bath A solder vessel that meets the requirements of 3.3.2 **shall** be used. The solder **shall** meet the requirements of 3.2.1. Solder bath temperatures and solder contamination control **shall** be in accordance with 3.5.1 and 3.5.2.

4.2.3.1.2 Dipping Device A mechanical or electromechanical dipping device similar to the device shown in Figure 4–1 **shall** be used unless otherwise agreed to between user and vendor. The rate of immersion, dwell time, and rate of withdrawal **shall** be within the test limits defined in 4.2.3.3. Wobble, vibration, and other extraneous movements **shall** be minimized.

4.2.3.2 Preparation Specimen preparation **shall** be in accordance with 3.4.

- For application of standard solderable wires for lugs, tabs, terminals, stranded wires greater than 1.016 mm [0.040 in] diameter, and solid wires greater than 1.143 mm [0.045 in] diameter all specimens **shall** have a wrap of 1.5 turns of the standard wires around the portion of the specimen to be tested.
- The standard wrapping wires as described in 3.2.4, **shall** be wrapped in such a manner so that it will not move during the solder dip. Examples of this wrap are shown in Figures 4–5 through 4–8.
- Special instructions concerning the portion of the specimens to be wrapped **shall** be specified in the individual specification, if necessary.
- For lugs and tabs designed to accept wires smaller than 0.6 mm [0.024 in] diameter, the standard copper wrapping wires specified in 3.2.4 **shall** be the same size for which the lugs and tabs are designed.

4.2.3.3 Procedure

- The flux **shall** be at ambient (room) temperature and per 3.2.2.
- Terminations **shall** be immersed in the flux to the minimum depth necessary to cover the surface to be tested.
- The surface to be tested **shall** be immersed for 5 to 10 seconds and allowed to drain for 10 to 60 seconds.
- The dross and burned flux **shall** be skimmed from the surface of the molten solder just before immersing the terminations in the solder.

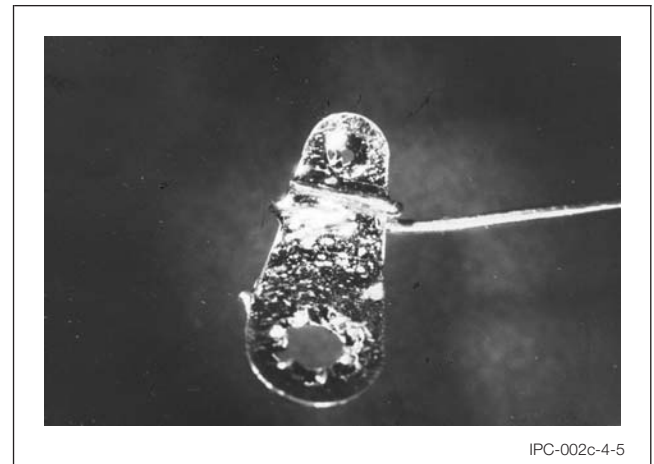

Figure 4–5 Illustration of Acceptable Solderable Terminal

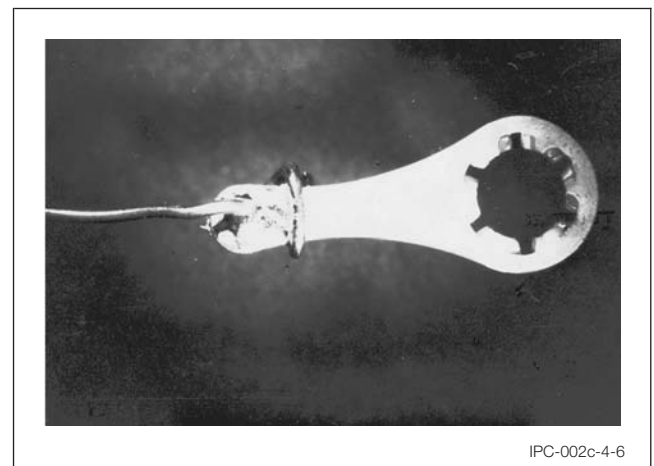

Figure 4–6 Illustration of Unsolderable Terminal

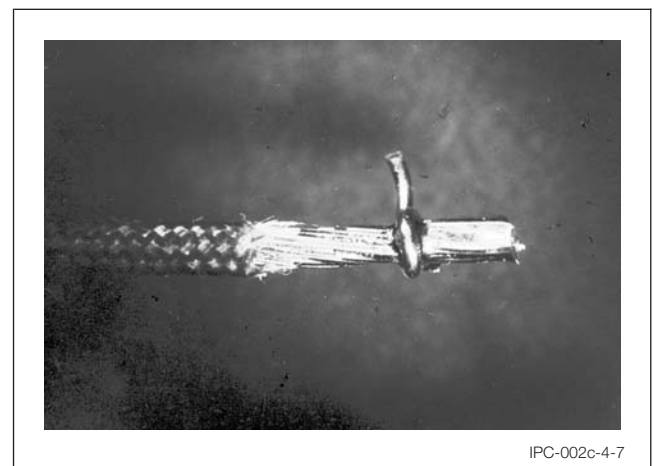

Figure 4–7 Illustration of Acceptable Solderable Stranded Wire

- Immerse and withdraw at a rate of 25 ± 6 mm [0.984 \pm 0.24 in] per second and dwell for 7 ± 0.50 seconds.
- The part **shall** be attached to a dipping device and the flux-covered terminations immersed once in the molten solder to the same depth specified in 4.2.3.3b.

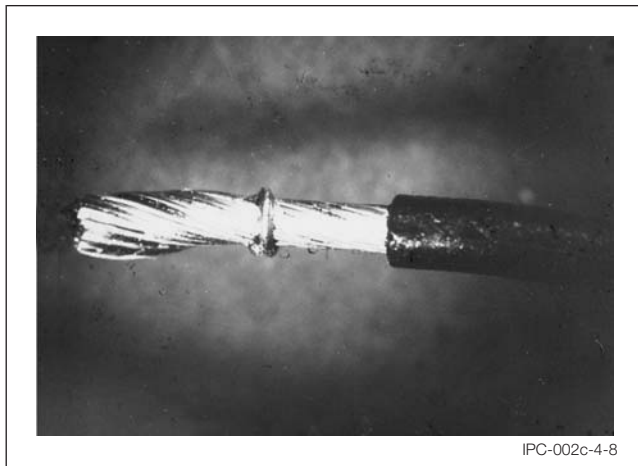

Figure 4-8 Illustration of Partially Solderable Stranded Wire Showing Incomplete Fillet

- g. After the dipping process, the part **shall** be allowed to cool in air.
- h. Before examination, all terminations **shall** have all visible flux residue removed per 3.2.3.

4.2.3.4 Evaluation

4.2.3.4.1 Magnification Parts **shall** be examined at 10X using the equipment specified in 3.3.3.

4.2.3.4.2 Accept/Reject Criteria The criteria for acceptable solderability of lugs, tabs, terminals, stranded wires greater than 1.016 mm [0.040 in] diameter, solid wire greater than 1.143 mm [0.045 in] diameter are:

- a. A minimum of 95% of the total length of fillet between wrap wires and termination **shall** be tangent to the surface of the termination and be free of anomalies such as pinholes.
- b. A ragged or interrupted tangency line indicates a defect.

In case of dispute, the percent of fillet-length with defects **shall** be determined by their actual measurement. See Figure B-4 in Appendix B that serves as an aid in the evaluation of the 5% allowable defects.

4.2.4 Test D – Tin/Lead or Lead-Free Solder – Resistance to Dissolution of Metallization Test This test is to reveal a susceptibility to loss of solderability due to either:

- a. Dissolution of metallization over unsolderable base material (as indicated by loss of wetting), or
- b. Accumulation of impurities from the basis metal (as indicated by dewetting).

4.2.4.1 Apparatus

4.2.4.1.1 Solder Pot/Bath A solder vessel that meets the requirements of 3.3.2 **shall** be used. The solder **shall** meet the requirements of 3.2.1. Solder bath temperatures and solder contamination control **shall** be in accordance with 3.5.1 and 3.5.2.

4.2.4.1.2 Dipping Device A mechanical or electromechanical dipping device similar to the device shown in Figure 4-1 **shall** be used unless otherwise agreed to between user and vendor. The rate of immersion, dwell time, and rate of withdrawal **shall** be within the test limits defined in 4.2.4.3.

4.2.4.1.3 Attitude (Angle of Immersion) All components **shall** be dipped using a vertical motion to ensure complete immersion of the surfaces to be soldered.

4.2.4.2 Preparation Specimen preparation **shall** be in accordance with 3.4.

4.2.4.3 Procedure

- a. Dross and burned flux **shall** be skimmed from the surface of the molten solder immediately before dipping.
- b. The flux-covered component metallization **shall** be immersed only once in the molten solder to a minimum depth to completely cover the termination being tested.
- c. The angle of immersion **shall** be between 20° and 45°.
- d. Immerse and withdraw at a rate of 25 ± 6 mm [0.984 ± 0.24 in] per second and dwell for 30 +/- 5 seconds.

4.2.4.4 Evaluation

4.2.4.4.1 Magnification Parts **shall** be examined at 10X using the equipment specified in 3.3.3. For fine pitch components (0.5 mm [0.020 in] pitch or less) the inspection magnification **shall** be 30X.

4.2.4.4.2 Accept/Reject Criteria The criteria for acceptable resistance to leaching/dewetting **shall** be no more than 5% of the solderable metallization exhibiting exposed underlying, non-wettable base metal or metallization layers or portions of the ceramic substrate after exposure to molten solder.

4.2.5 Test S – Tin/Lead Solder – Surface Mount Process Simulation Test This test simulates actual surface mount component performance in a reflow process.

4.2.5.1 Apparatus

4.2.5.1.1 Stencil/Screen A stencil or screen with pad geometry openings that is appropriate for the terminals being tested **shall** be used. Unless otherwise agreed upon between vendor and user, the nominal stencil thickness **shall** be per Table 4–1.

Table 4–1 Stencil Thickness Requirements

Nominal Stencil Thickness	Component Lead Pitch
0.10 mm [0.00394 in]	<0.508 mm [<0.020 in]
0.15 mm [0.00591 in]	0.508–0.635 mm [0.020–0.025 in]
0.20 mm [0.00787 in]	>0.635 mm [>0.025 in]

4.2.5.1.2 Paste Application Tool A rubber or metal squeegee device **shall** be used to distribute paste across stencil/screen.

4.2.5.1.3 Test Substrate A ceramic substrate 0.635 mm [0.025 in] nominal thickness **shall** be used for testing. Other non-wettable substrates may be used if agreed upon between vendor and user.

4.2.5.1.4 Tin/lead Reflow Equipment An IR/convection reflow oven, vapor phase reflow system, or oven capable of reaching the reflow temperature of the tin/lead paste **shall** be used. Unless otherwise agreed upon between vendor and user the reflow parameters **shall** be per Table 4–2.

Table 4–2 Reflow Parameter Requirements

	Temperature	Time
Vapor Phase Reflow	215–219°C [419–426°F]	30–60 seconds dwell at reflow
IR/Convection Reflow	150–170°C [302–338°F] Preheat	50–70 seconds
	215–230°C [419–446°F] Reflow	50–70 seconds
Oven	215–230°C [419–446°F]	2–5 minutes (until reflow is assured)

Note: Table 4–2 reflow parameter values are for solderability testing purposes and are not related to moisture sensitivity level reflow test parameters.

4.2.5.2 Preparation Specimen preparation **shall** be in accordance with 3.4.

4.2.5.3 Procedure

- Place solder paste (per 3.2.1) onto stencil/screen and print the terminal pattern onto the test substrate by wiping paste over the stencil/screen in one smooth motion using rubber or metal squeegee.
- Remove the stencil/screen carefully to avoid smearing the paste print.
- Verify a paste print equivalent in geometry to the terminal of the device to be tested.
- Place the terminals of the component being tested on the solder paste print.
- Verify component placement by appropriate magnification.
- Place test substrate on applicable reflow equipment and conduct reflow process.
- After reflow, carefully remove substrate with component(s) and allow to cool to room temperature.
- Remove component(s) from substrate. Component leads may adhere slightly to substrate due to flux residue.
- Before examination, all leads **shall** have all visible flux residues removed per 3.2.3. Care should be exercised in flux residue removal process to not damage leads.

4.2.5.4 Evaluation

4.2.5.4.1 Magnification Parts **shall** be examined at 10X using the equipment specified in 3.3.3. For fine pitch leaded/termination parts (0.5 mm [0.020 in] pitch or less) the inspection magnification **shall** be 30X.

4.2.5.4.2 Accept/Reject Criteria All leads **shall** exhibit a continuous solder coating free from defects for a minimum of 95% of the critical area of any individual lead. For exposed pad packages the exposed pad surfaces **shall** exhibit a continuous solder coating free from defects for a minimum of 80% of the critical area of those surfaces. Anomalies other than dewetting, nonwetting, and pin holes are not cause for rejection (see Appendices A and B). Exposed terminal metal is allowable on surface mount components at the toe end and on the vertical surfaces that are either unplated or sheared during component fabrication.

4.2.6 Test A1 – Lead-free Solder – Solder Bath/Dip and Look Test (Leads, Wires, etc.) This test is for solder bath/dip and look testing of leaded components, solid wires, and stranded wires greater than 0.254 mm [0.01 in] minimum.

4.2.6.1 Apparatus

4.2.6.1.1 Solder Pot/Bath A solder vessel that meets the requirements of 3.3.2 **shall** be used. The solder **shall** meet the requirements of 3.2.1. Solder bath temperatures and solder contamination control **shall** be in accordance with 3.5.1 and 3.5.2.

4.2.6.1.2 Dipping Device A mechanical or electromechanical dipping device similar to the device shown in Figure 4-1 **shall** be used unless otherwise agreed to between user and vendor. The rate of immersion, dwell time, and rate of withdrawal **shall** be within the test limits defined in 4.2.6.3. Perpendicularity of through-hole component leads to solder surface **shall** be maintained. Leaded surface mount components **shall** be immersed at between 20° and 45° (or 90° if agreed upon) to the solder surface (see Figure 4-2). This angle **shall** remain consistent for any given component type. Wobble, vibration and other extraneous movements **shall** be minimized.

4.2.6.2 Preparation Specimen preparation **shall** be in accordance with 3.4.

4.2.6.3 Procedure

a. Dross and burned flux **shall** be skimmed from the surface of the molten solder immediately before dipping.

- b. The fluxed specimen **shall** be immersed in the molten solder to within 1.27 mm [0.050 in] of the component body or to the seating plane (whichever is further from the component body) for through-hole leaded components (see Figure 4-3).
- c. Immerse and withdraw at 25 ± 6 mm [0.984 \pm 0.24 in] per second and dwell for 5 +0/-0.5 seconds (see 5.2).
- d. After withdrawal, the solder **shall** be allowed to solidify by air cooling while the specimen is maintained in the test attitude.
- e. Before examination, all leads **shall** have all visible flux residues removed per 3.2.3.

4.2.6.4 Evaluation

4.2.6.4.1 Magnification Parts **shall** be examined at 10X using the equipment specified in 3.3.3. For fine pitch leaded parts (0.5 mm [0.020 in] pitch or less) the inspection magnification **shall** be 30X.

4.2.6.4.2 Accept/Reject Criteria All leads **shall** exhibit a continuous solder coating free from defects for a minimum of 95% of the critical area of any individual lead. For exposed pad packages the exposed pad surfaces **shall** exhibit a continuous solder coating free from defects for a minimum of 80% of the critical area of those surfaces. Anomalies other than dewetting, nonwetting, and pin holes are not cause for rejection (see Appendices A and B). Exposed terminal metal is allowable on surface mount components at the toe end and on the vertical surfaces that are either unplated or sheared during component fabrication.

4.2.7 Test B1 – Lead-free Solder – Solder Bath/Dip and Look Test (Leadless Components) This test is for solder bath/dip and look testing of leadless components.

4.2.7.1 Apparatus

4.2.7.1.1 Solder Pot/Bath A solder vessel that meets the requirements of 3.3.2 **shall** be used. The solder **shall** meet the requirements of 3.2.1. Solder bath temperatures and solder contamination control **shall** be in accordance with 3.5.1 and 3.5.2.

4.2.7.1.2 Vertical Dipping Device A mechanical or electro-mechanical dipping device similar to the device shown in Figure 4–1 **shall** be used unless otherwise agreed to between user and vendor. The rate of immersion, dwell time, and rate of withdrawal **shall** be within the test limits defined in 4.2.7.3. Surface mount leadless components **shall** be immersed at an angle to the solder surface of 20°- 45° and 90° for discrete chip components and exposed pad packages. Other immersion angles may be used if agreed upon between vendor and user.

4.2.7.2 Preparation Specimen preparation **shall** be in accordance with 3.4.

4.2.7.3 Procedure

a. Dross and burned flux **shall** be skimmed from the surface of the molten solder immediately before dipping.

b. The fluxed specimen **shall** be immersed in the molten solder 0.10 mm [0.0039 in] minimum (see Figure 4–4). Immerse and withdraw at 25 ± 6 mm [0.984 ± 0.24 in] per second and dwell for $5 +0/-0.5$ seconds. Massive components may require a longer molten solder dwell time (see 5.2).

c. After withdrawal, the solder **shall** be allowed to solidify by air cooling while the specimen is maintained in the test attitude.

d. Before examination, all terminations **shall** have all visible flux residues removed per 3.2.3.

4.2.7.4 Evaluation

4.2.7.4.1 Magnification Parts **shall** be examined at 10X using the equipment specified in 3.3.3. For fine pitch termination parts (0.5 mm [0.020 in] pitch or less) the inspection magnification **shall** be 30X.

4.2.7.4.2 Accept/Reject Criteria All terminations **shall** exhibit a continuous solder coating free from defects for a minimum of 95% of the critical area of any individual termination. For exposed pad packages, the exposed pad surfaces **shall** exhibit a continuous solder coating free from defects for a minimum of 80% of the critical area of those surfaces. Anomalies other than dewetting, nonwetting, and pin holes are not cause for rejection (see Appendices A and B). Exposed terminal metal is allowable on surface mount components at the toe end and on the vertical surfaces that are either unplated or sheared during component fabrication.

4.2.8 Test C1 – Lead-free Solder – Wrapped Wires Test (Lugs, Tabs, Terminals, Large Stranded Wires) This test is for wrapped wires testing of lugs, tabs, terminals, stranded wires greater than 1.016 mm [0.040 in] diameter, and solid wires greater than 1.143 mm [0.045 in] diameter.

4.2.8.1 Apparatus

4.2.8.1.1 Solder Pot/Bath A solder vessel that meets the requirements of 3.3.2 **shall** be used. The solder **shall** meet the requirements of 3.2.1. Solder bath temperatures and solder contamination control **shall** be in accordance with 3.5.1 and 3.5.2.

4.2.8.1.2 Dipping Device A mechanical or electromechanical dipping device similar to the device shown in Figure 4-1 **shall** be used unless otherwise agreed to between user and vendor. The rate of immersion, dwell time, and rate of withdrawal **shall** be within the test limits defined in 4.2.8.3. Wobble, vibration, and other extraneous movements **shall** be minimized.

4.2.8.2 Preparation Specimen preparation **shall** be in accordance with 3.4.

- a. For application of standard solderable wires for lugs, tabs, terminals, stranded wires greater than 1.016 mm [0.040 in] diameter, and solid wires greater than 1.143 mm [0.045 in] diameter, all specimens **shall** have a wrap of 1.5 turns of the standard wires around the portion of the specimen to be tested.
- b. The standard wrapping wires as described in 3.2.4 **shall** be wrapped in such a manner so that it will not move during the solder dip. Examples of this wrap are shown in Figures 4-5 through 4-8.
- c. Special instructions concerning the portion of the specimens to be wrapped **shall** be specified in the individual specification, if necessary.
- d. For lugs and tabs designed to accept wires smaller than 0.6 mm [0.024 in] diameter, the standard copper

wrapping wires specified in 3.2.4 **shall** be the same size for which the lugs and tabs are designed.

4.2.8.3 Procedure

- a. The flux **shall** be at ambient (room) temperature per 3.2.2.
- b. Terminations **shall** be immersed in the flux to the minimum depth necessary to cover the surface to be tested.
- c. The surface to be tested **shall** be immersed for 5 to 10 seconds and allowed to drain for 10 to 60 seconds.
- d. The dross and burned flux **shall** be skimmed from the surface of the molten solder just before immersing the terminations in the solder.
- e. Immerse and withdraw at a rate of 25 ± 6 mm [0.984 \pm 0.24 in] per second and dwell for 7 ± 0.50 seconds.
- f. The part **shall** be attached to a dipping device and the flux-covered terminations immersed once in the molten solder to the same depth specified in 4.2.8.3b.
- g. After the dipping process, the part **shall** be allowed to cool in air.
- h. Before examination, all terminations **shall** have all visible flux residue removed per 3.2.3.

4.2.8.4 Evaluation

4.2.8.4.1 Magnification Parts **shall** be examined at 10X using the equipment specified in 3.3.3.

4.2.8.4.2 Accept/Reject Criteria The criteria for acceptable solderability of lugs, tabs, terminals, stranded wires greater than 1.016 mm [0.040 in] diameter, solid wires greater than 1.143 mm [0.045 in] diameter are:

- a. A minimum of 95% of the total length of fillet between wrap wires and termination **shall** be tangent to the surface of the termination and be free of anomalies such as pinholes.
- b. A ragged or interrupted tangency line indicates a defect.

In case of dispute, the percent of fillet-length with defects **shall** be determined by their actual measurement. See Figure B-4 in Appendix B that serves as an aid in the evaluation of the 5% allowable defects.

4.2.9 Test S1 – Lead-free Solder – Surface Mount Process Simulation Test This test simulates actual surface mount component performance in a reflow process.

4.2.9.1 Apparatus

4.2.9.1.1 Stencil/Screen A stencil or screen with pad geometry openings that is appropriate for the terminals being tested **shall** be used. Unless otherwise agreed upon between vendor and user the nominal stencil thickness **shall** be per Table 4–3.

Table 4–3 Stencil Thickness Requirements

Nominal Stencil Thickness	Component Lead Pitch
0.10 mm [0.00394 in]	<0.508 mm [<0.020 in]
0.15 mm [0.00591 in]	0.508–0.635 mm [0.020–0.025 in]
0.20 mm [0.00787 in]	>0.635 mm [>0.025 in]

4.2.9.1.2 Paste Application Tool A rubber or metal squeegee device **shall** be used to distribute paste across stencil/screen.

4.2.9.1.3 Test Substrate A ceramic substrate 0.635 mm [0.025 in] nominal thickness **shall** be used for testing. Other non-wettable substrates may be used if agreed upon between vendor and user.

4.2.9.1.4 Lead-Free Reflow Equipment An IR/convection reflow oven, vapor phase reflow system, or oven capable of reaching the reflow temperature of the lead-free paste **shall** be used. Unless otherwise agreed upon between vendor and user the reflow parameters **shall** be per Table 4–4.

Table 4–4 Lead-free Reflow Parameter Requirements

	Temperature	Time
Vapor Phase Reflow	217–240°C [423–464°F]	45–90 seconds dwell at reflow
IR/Convection Reflow	150–180°C [302–356°F] Preheat	60–120 seconds
	230–250°C [446–482°F] Reflow	30–60 seconds
Oven	230–250°C [446–482°F]	2–5 minutes (until reflow is assured)

Note: Table 4–4 reflow parameter values are for solderability testing purposes and are not related to moisture sensitivity level reflow test parameters.

4.2.9.2 Preparation Specimen preparation **shall** be in accordance with 3.4.

4.2.9.3 Procedure

- Place solder paste (see 3.2.1) onto stencil/screen and print the terminal pattern onto the test substrate by wiping paste over the stencil/screen in one smooth motion using rubber or metal squeegee.
- Remove the stencil/screen carefully to avoid smearing the paste print.
- Verify a paste print equivalent in geometry to the terminal of the device to be tested.
- Place the terminals of the component being tested on the solder paste print.
- Verify component placement by appropriate magnification.
- Place test substrate on applicable reflow equipment and conduct reflow process.
- After reflow, carefully remove substrate with component(s) and allow to cool to room temperature.
- Remove component(s) from substrate. Component leads may adhere slightly to substrate due to flux residue.
- Before examination, all leads **shall** have all visible flux residues removed per 3.2.3. Care should be exercised in flux residue removal process to not damage leads.

4.2.9.4 Evaluation

4.2.9.4.1 Magnification Parts **shall** be examined at 10X using the equipment specified in 3.3.3. For fine pitch leaded/termination parts (0.5 mm [0.020 in] pitch or less) the inspection magnification **shall** be 30X.

4.2.9.4.2 Accept/Reject Criteria All leads **shall** exhibit a continuous solder coating free from defects for a minimum of 95% of the critical area of any individual lead. For exposed pad packages, the exposed pad surfaces **shall** exhibit a continuous solder coating free from defects for a minimum of 80% of the critical area of those surfaces. Anomalies other than dewetting, nonwetting, and pin holes are not cause for rejection (see Appendices A and B). Exposed terminal metal is allowable on surface mount components at the toe end and on the vertical surfaces that are either unplated or sheared during component fabrication.

4.3 Force Measurement Tests

4.3.1 Test E – Tin/Lead Solder – Wetting Balance Solder Pot Test (Leaded Components) This test is for wetting balance testing of leaded components.

4.3.1.1 Apparatus A solder meniscus force measuring device (wetting balance) which includes a temperature controlled solder pot containing solder per 3.2.1 and maintained per 3.5.1 and 3.5.2 **shall** be used. The equipment **shall** have a means of recording force as a function of time, such as a chart recorder, data logger, or computer (see Figure 4–9).

4.3.1.1.1 Dipping Device A mechanical or electromechanical dipping device incorporated in the wetting balance **shall** be used. The device **shall** be preset to produce an immersion and emersion rate as specified in 4.3.1.3. The specimen dwell time is controlled to the time specified in 4.3.1.3. A device to sense contact of the lead(s) with the molten solder bath **shall** also be part of the fixture or instrument.

4.3.1.2 Preparation Specimen preparation **shall** be in accordance with 3.4.

4.3.1.3 Procedure

- Flux per 3.2.2 **shall** be used. The flux **shall** be at ambient (room) temperature.
- Leads and terminations **shall** have flux applied uniformly and to cover the surfaces to be tested.

- Dross and burned flux **shall** be skimmed from the surface of the molten solder immediately before dipping.
- The flux covered termination **shall** be immersed only once in the molten solder to a depth of 0.10 mm [0.0039 in].
- The angle of immersion **shall** be 20° – 45° (see Figure 4–2).
- Immerse and withdraw at 1 mm – 5 mm [0.04 - 0.20 in] per second and dwell for 5 +0/-0.5 seconds. Massive components may require a longer solder dwell time (see 5.2).

4.3.1.4 Evaluation

4.3.1.4.1 Magnification Parts **shall** be examined at 10X using the equipment specified in 3.3.3. For fine pitch leaded/termination parts (0.5 mm [0.020 in] pitch or less) the inspection magnification **shall** be 30X.

4.3.1.4.2 Accept/Reject Criteria Suggested criteria for solderability evaluation for Test E are listed in Table 4–5. Figures 4–10 and 4–11 illustrate the suggested criteria of Table 4–5. In addition, the area of the test sample with fresh solder adhesion **shall** be greater than the area that was immersed in the solder bath (i.e., the component **shall** exhibit positive wicking beyond its immersion depth).

4.3.1.4.3 Gauge Repeatability and Reproducibility (GR&R) Protocol Appendix H contains a suggested GR&R protocol that may be used by the supplier and user to ensure that the respective wetting balance equipment are correctly calibrated.

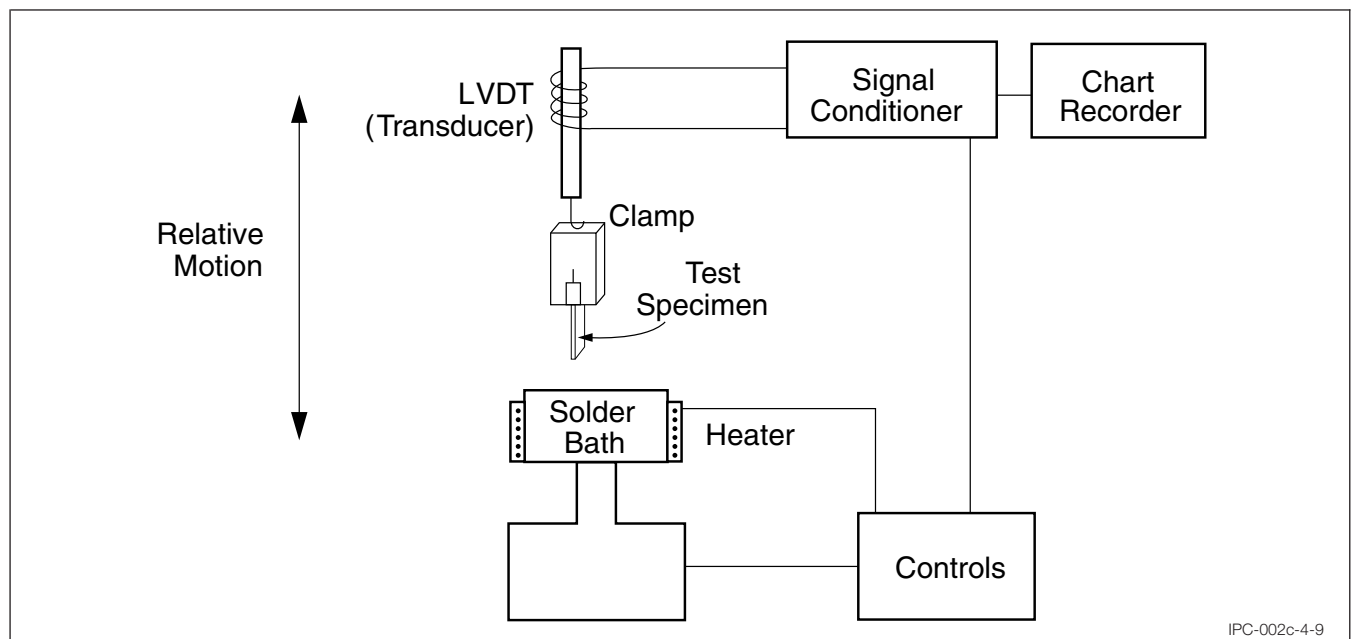

Figure 4–9 Wetting Balance Apparatus

Table 4-5 Wetting Balance Parameter and Suggested Evaluation Criteria

Parameter	Description	Suggested Criteria ¹	
		Set A	Set B
T ₀	Time to buoyancy corrected zero	≤1 second	≤2 seconds
F2	Wetting force at two seconds from start of test	50% of maximum theoretical wetting force at or before two seconds ²	Positive value at or before two seconds
F5	Wetting force at five seconds from start of test	No less than 90% of the F2 Value	No less than 90% of the F2 Value
AA	Integrated value of area of the wetting curve from start of test	Area calculated using sample buoyancy and 50% maximum theoretical force ³	> zero (0)

1. This suggested criteria has been established as a two-tier evaluation format with Set A being more stringent. Components meeting Set A suggested criteria are applicable to a larger soldering process window than components meeting Set B suggested criteria. It should be recognized that components meeting Set B suggested criteria may be completely acceptable to a larger process window but the user must determine which criteria set best integrates into their process.
2. See Appendix C for the method of calculating the maximum theoretical force.
3. See Appendix D for the method of calculation. (It is suggested that this method of calculation be programmed into the software used for control of the wetting balance test equipment.)

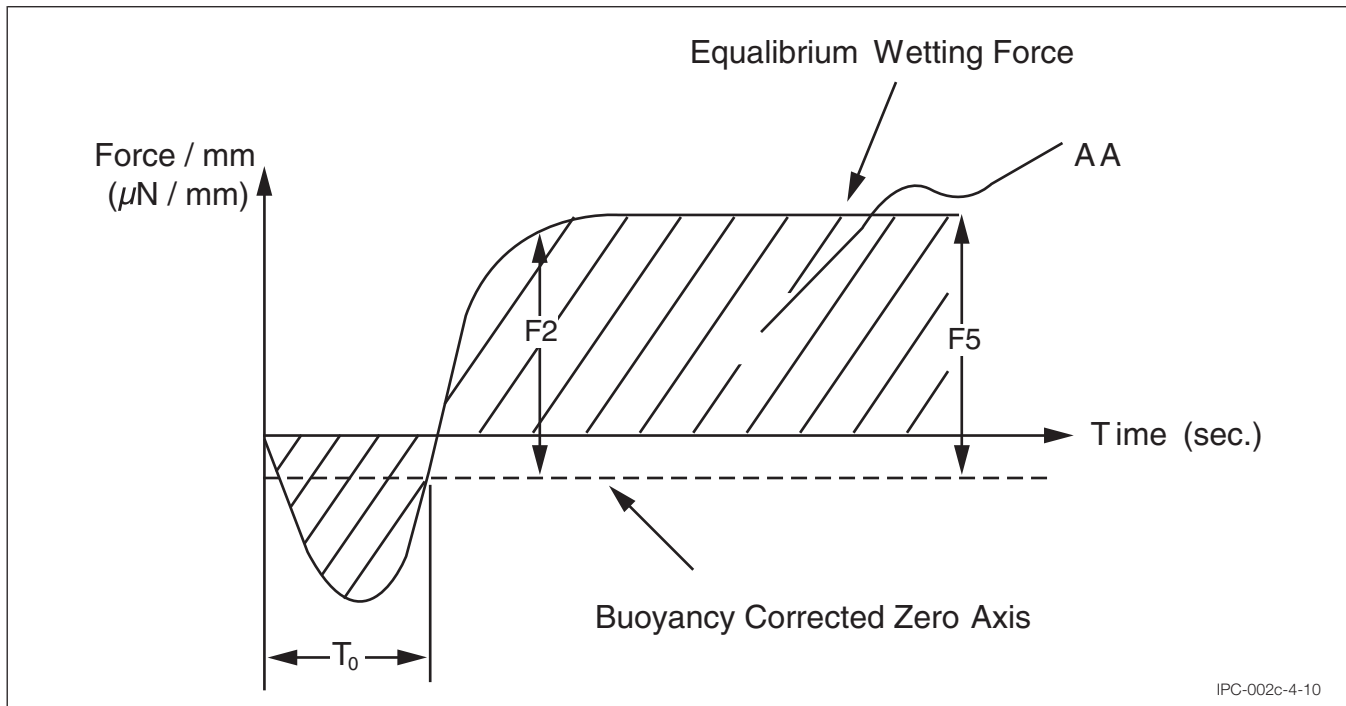

Figure 4-10 Set A Wetting Curve

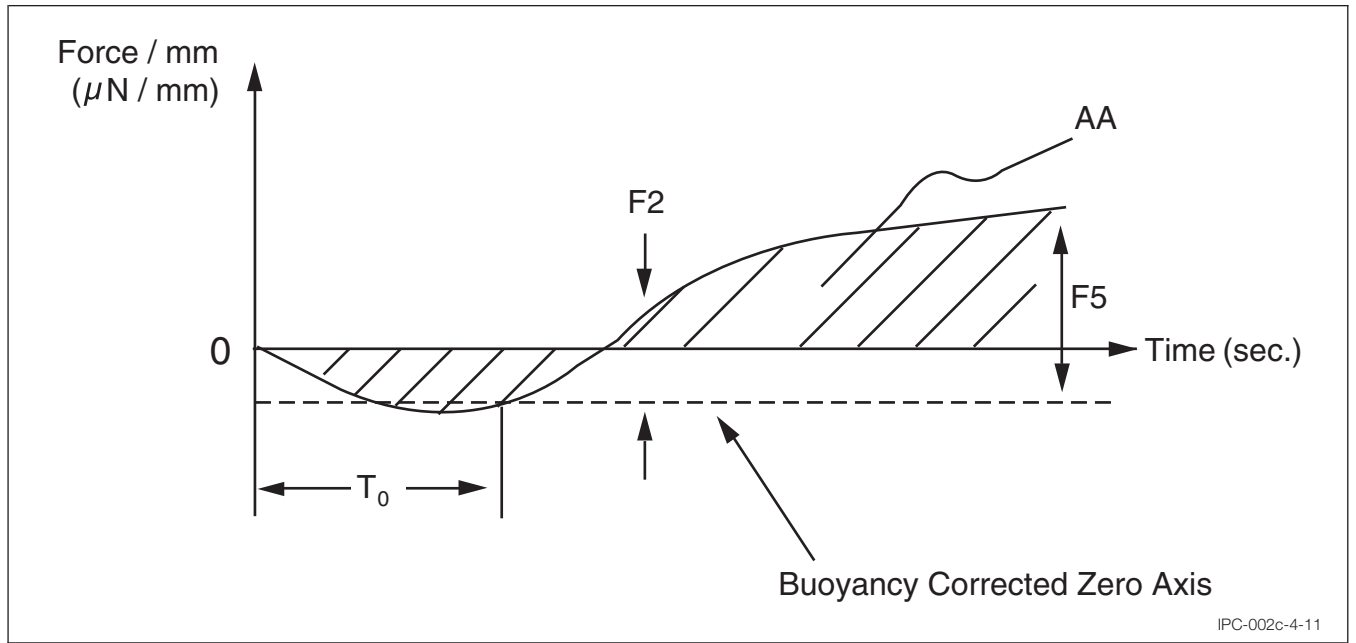

Figure 4-11 Set B Wetting Curve

4.3.2 Test F – Tin/Lead Solder – Wetting Balance Solder Pot Test (Leadless Components) This test is for wetting balance testing of leadless components.

4.3.2.1 Apparatus A solder meniscus force measuring device (wetting balance) which includes a temperature controlled solder pot containing solder per 3.2.1 and maintained per 3.5.1 and 3.5.2 **shall** be used. The equipment **shall** have a means of recording force as a function of time, such as a chart recorder, data logger, or computer (see Figure 4–9).

4.3.2.1.1 Dipping Device A mechanical or electromechanical dipping device incorporated in the wetting balance **shall** be used. The device **shall** be preset to produce an immersion and emersion rate as specified in 4.3.2.3. The specimen dwell time is controlled to the time specified in 4.3.2.3.

4.3.2.2 Preparation Specimen preparation **shall** be in accordance with 3.4.

4.3.2.3 Procedure

- a. Flux per 3.2.2 **shall** be used and **shall** be at ambient (room) temperature.
- b. Leads and terminations **shall** have flux applied uniformly and to cover the surfaces to be tested.
- c. Immerse and withdraw at 1 mm – 5 mm [0.04 in – 0.20 in] per second and dwell for 5 +0/-0.5 seconds. Massive components may require a longer solder dwell time (see 5.2).

- d. After application of the flux and post dip dwell, the specimen **shall** be mounted on the test equipment.
- e. Dross and burned flux **shall** be skimmed from the surface of the molten solder immediately before dipping.
- f. The flux covered termination **shall** be immersed only once in the molten solder to a depth of 0.10 mm [0.0039 in] minimum.
- g. The angle of immersion **shall** be per Figure 4–4.
- h. A full curve **shall** be recorded using the equipment specified in 4.3.2.1.

4.3.2.4 Evaluation

4.3.2.4.1 Magnification Parts **shall** be examined at 10X using the equipment specified in 3.3.3. For fine pitch termination parts (0.5 mm [0.020 in] pitch or less) the inspection magnification **shall** be 30X.

4.3.2.4.2 Accept/Reject Criteria Suggested criteria for solderability evaluation for Test F are listed in Table 4–5. Figures 4–10 and 4–11 illustrate the suggested criteria of Table 4–5. In addition, the area of the test sample with fresh solder adhesion **shall** be greater than the area that was immersed in the solder bath (i.e., the component **shall** exhibit positive wicking beyond its immersion depth).

4.3.2.4.3 Gauge Repeatability and Reproducibility (GR&R) Protocol Appendix H contains a suggested GR&R protocol that may be used by the supplier and user to ensure that the respective wetting balance equipment are correctly calibrated.

4.3.3 Test G – Tin/Lead Solder – Wetting Balance Globule Test This test is for wetting balance globule testing of components.

4.3.3.1 Apparatus A solder meniscus force measuring device (wetting balance) which includes a temperature controlled vertical, cylindrical iron shaft shrunk fit into an aluminum housing on which is placed a specific sized piece of solder. Examples are: a 200 mg piece of solder for a 4 mm diameter globule block, a 100 mg piece of solder for a 3.2 mm diameter globule block, a 25 mg piece of solder for a 2 mm globule block or a 5 mg piece for a 1 mm globule block. The molten solder globule should ideally be replaced after each solderability test, but may be re-used for very small components that do not remove more than 1% of the solder volume per solder test for up to 5 tests. The equipment **shall** have a means of recording force as a function of time, such as a chart recorder, data logger or computer.

4.3.3.1.1 Dipping Device A mechanical or electromechanical dipping device incorporated in the wetting balance **shall** be used. The device **shall** be preset to produce an immersion and emersion rate as specified in 4.3.3.3.3. The specimen dwell time is controlled to the time specified in 4.3.3.3.3.

4.3.3.2 Materials

4.3.3.2.1 Flux The flux used **shall** be in accordance with 3.2.2.

4.3.3.2.2 Solder The solder **shall** be in accordance with 3.2.1. Other alloys may be used upon agreement between user and other parties.

4.3.3.2.3 Test Specimen The test specimen **shall** either be a full component or a lead that has been carefully removed from the component. Ideally the cross-section of the component to be dipped is either rectangular, square or round, to facilitate calculation of the theoretical maximum wetting force. Ideally no burr should be present but, if they are, generally they will be on the components used in production and should not be removed, as they may actually be the cause of the poor solderability. No cleaning of the specimen is allowed. Conditioning, if any, must be agreed to by the tester and other party in advance.

4.3.3.3 Procedure

4.3.3.3.1 Temperature of the Solder The temperature of the solder is to be stabilized at the required temperature for the test before commencing the test. This temperature **shall** be per 3.5.1.

4.3.3.3.2 Fluxing A very small amount of flux is carefully applied to the surface or lead to be tested and the solder globule using a clean cotton tip or bud. No excess flux **shall** be ready to drip off the fluxed part or the excess flux must be drained off by carefully touching the lowest point on the surface to be tested with a piece of clean chemical lab filter paper. For this testing, ideally a small amount of flux should be kept in a small container that is only opened to immerse the cotton tip to wet it with flux. The cotton tips should be thrown away and replaced with fresh ones every 5 to 10 tests, with all tests done in the same testing interval. If testing is interrupted for more than a few minutes, then a new tip should be used.

4.3.3.3.3 Dipping Angle, Immersion Depth, and Immersion Rates The appropriate clip **shall** be chosen to hold the part as specified in Table 4–6 and illustrated in Figure 4–12. Without contaminating the surfaces to be tested, the specimen is mounted in the appropriate clip or other device supplied by the solderability tester manufacturer and carefully attached to the machine so as to not damage the transducer or dislodge the component from its orientation in the clip or other holder. The distance between the solderable surface of the sample and the solder globule should be fixed. An immersion speed between 1 mm/second and 5 mm/second [0.039 in/second and 0.20 in/second] should ensure that most test specimens are fully immersed. A dwell time of 5 seconds **shall** be used. A dwell time of 10 seconds may be necessary for large components or components with high thermal mass (see 5.2).

4.3.3.3.4 Preheat The decision to use preheat should be by prior agreement between user and supplier (AABUS).

4.3.3.4 Evaluation

4.3.3.4.1 Magnification Magnifications of up to 100X may be necessary, for example, to examine components smaller than 0402 chip components.

4.3.3.4.2 Suggested Criteria Prior to any post-test examination, all specimens **shall** have the flux removed using a cleaning agent in accordance with 3.2.3. The area of the test sample with fresh solder adhesion **shall** be greater than the area that was immersed in the solder globule, (i.e. the component **shall** exhibit positive wetting beyond its immersion depth). In addition, Table 4–7 lists suggested criteria.

Table 4-6 Dipping Angle and Immersion Depth for Components (Directly from IEC 60068-2-69)

Component ^a		Dipping angle ^b	Figure (See Fig. 4-12)	Immersion depth (mm)	Pin size (mm)	Globule weight (mg)	Remarks
Capacitors	1005 (0402)	Horizontal or Vertical	2A, 2B	0.10	2	25	
	1608 (0603)				Horizontal	2A	
	2012 (0805)	4	200				
	3216 (1206)						
Resistors	1005 (0402)	Vertical	2B	0.10	2	25	
	1608 (0603)	Horizontal or Vertical	2A, 2B		3.2 or 4	100 or 200	
	2012 (0805)		2A,2B,2H ^c		4	200	
	3216 (1206)						
Tantalum capacitors, LEDs	Case sizes A ^d ,B,C,D	Vertical	2H ^c	0.10	4	200	
Leaded SMD	SOT 23, 25, 26, 323, 343, 353, 363	20 – 45	2D	0.10	2	25	1 outer pin only Remove sufficient leads to avoid bridging between tested leads
	SOT 89, SOT 223, 523		2F	0.20	4	200	
	Gull wing diode			0.25			
	Any SOIC VSO QFP, SOP		2D	0.20			
	PLCC, SOJ		Horizontal	2E	0.10		
QFN	QFN	Vertical	2H ^c	0.10	2	25	Caution from bridging
	Cylindrical SMD	Horizontal or Vertical	2A, 2B	0.25	4	200	
	SOD 80	Vertical	2B	0.20	4	200	
	Any BGA, CSP or LGA ^e	Horizontal	2G	0.10	1	10	Only peripheral balls can be tested, and only test down to 1.0 mm pitch

Not recommended for sizes below 1005 (0402).

Bath method is preferred for capacitors 3216 (1206) size.

The recommended dwell time is 5s, except for SOT 89 and SOT 223 components where 10s is recommended.

For Figure 2B, rightward offset distance from the crest of the solder globule **shall** be 0% to 15% of the pin diameter and **shall** avoid leftward offset.

^a Component names in parentheses, dimensions are expressed in Imperial.

^b Orientation of the specimen terminals or leads toward the solder surface.

^c Figure 2H is applicable to the components which do not have electrode toward the solder surface when Figure 2B is applied.

^d This test may only be applicable with certain test equipment.

^e This test is recommended only for those balls and bumps that will not melt at the respective temperature and are not designed to melt during reflow operation.

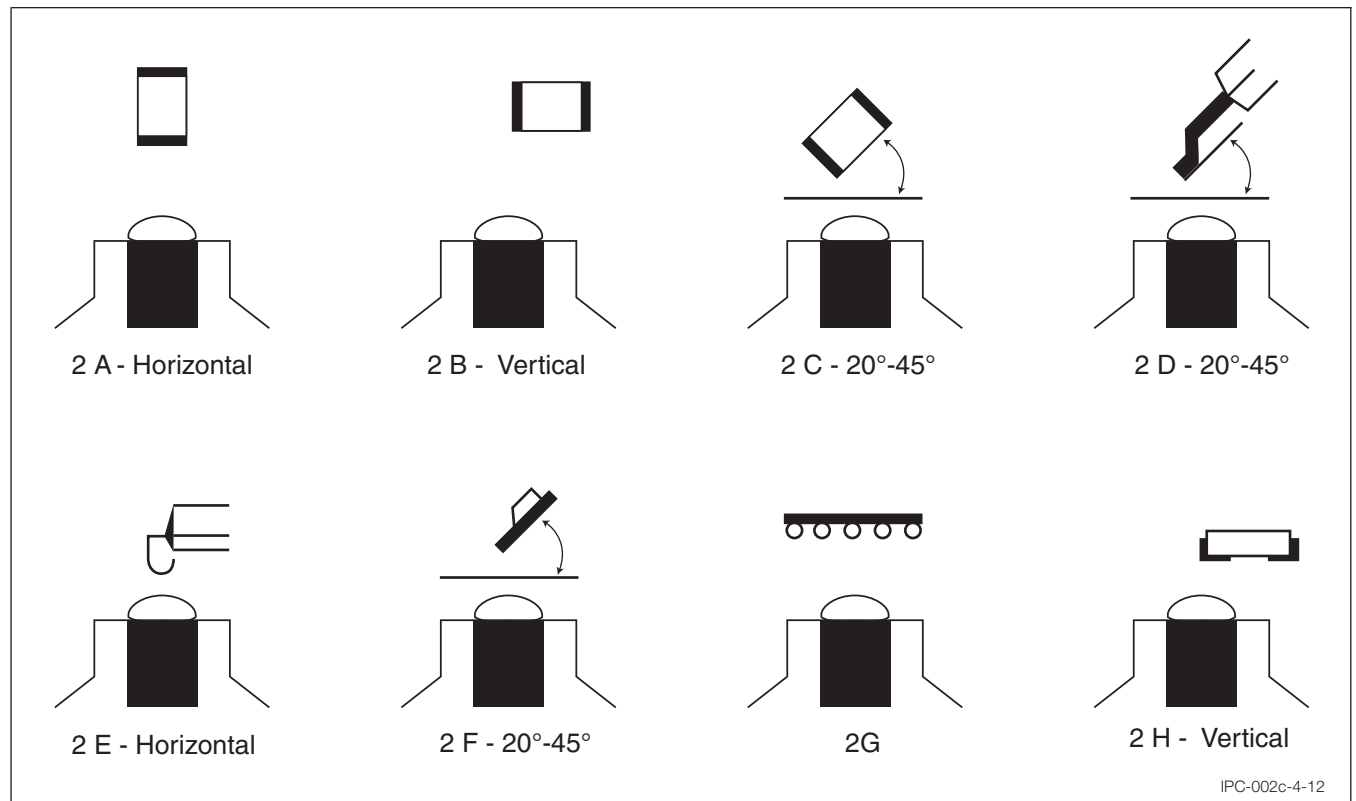

Figure 4-12 Component and Dipping Angle (Directly from IEC 60068-2-69)

Table 4-7 Wetting Parameters and Suggested Evaluation Criteria

Parameter	Description	Suggested Criteria	
		Set A	Set B
T ₀	Time to buoyancy corrected zero	≤1 second	≤2 seconds
F2	Wetting force at 2 seconds from start of test	≥50% maximum theoretical wetting force at or before 2 seconds	Positive value at or before 2 seconds
F5	Wetting force at 5 seconds from start of test	At or above the positive value of F2	At or above the value of F2
AA	Integrated value of area of the wetting curve from start of the test	≥area calculated using sample buoyancy and 50% maximum theoretical force	> zero (0)
F2	Wetting force at 2 seconds from start of test	≥25% maximum theoretical wetting force at or before 2 seconds	
F5	Wetting force at 5 seconds from start of test	At or above 90% of F2 value	

4.3.4 Test E1 - Lead-free Solder - Wetting Balance Solder Pot Test (Leaded Components) This test is for wetting balance testing of leaded components.

4.3.4.1 Apparatus A solder meniscus force measuring device (wetting balance) which includes a temperature controlled solder pot containing solder per 3.2.1 and maintained per 3.5.1 and 3.5.2 **shall** be used. The equipment **shall** have a means of recording force as a function of time, such as a chart recorder, data logger, or computer (see Figure 4-9).

4.3.4.1.1 Dipping Device A mechanical or electromechanical dipping device incorporated in the wetting balance **shall** be used. The device **shall** be preset to produce an immersion and emersion rate as specified in 4.3.4.3. The specimen dwell time is controlled to the time specified in 4.3.4.3. A device to sense contact of the lead(s) with the molten solder bath **shall** also be part of the fixture or instrument.

4.3.4.2 Preparation Specimen preparation **shall** be in accordance with 3.4.

4.3.4.3 Procedure

- a. Flux per 3.2.2 **shall** be used. The flux **shall** be at ambient (room) temperature.
- b. Leads and terminations **shall** have flux applied uniformly and to cover the surfaces to be tested.
- c. Dross and burned flux **shall** be skimmed from the surface of the molten solder immediately before dipping.

- d. The flux covered termination **shall** be immersed only once in the molten solder to a depth of 0.10 mm [0.0039 in].
- e. The angle of immersion **shall** be 20° – 45° (see Figure 4-2).
- f. Immerse and withdraw at 1 mm – 5 mm [0.04 - 0.20 in] per second and dwell for 5 +0/-0.5 seconds. Massive components may require a longer solder dwell time (see 5.2).

4.3.4.4 Evaluation

4.3.4.4.1 Magnification Parts **shall** be examined at 10X using the equipment specified in 3.3.3. For fine pitch leaded/termination parts (0.5 mm [0.020 in] pitch or less) the inspection magnification **shall** be 30X.

4.3.4.4.2 Accept/Reject Criteria Suggested criteria for solderability evaluation for Test E1 are listed in Table 4-5. Figures 4-10 and 4-11 illustrate the suggested criteria of Table 4-5. In addition, the area of the test sample with fresh solder adhesion **shall** be greater than the area that was immersed in the solder bath (i.e., the component **shall** exhibit positive wicking beyond its immersion depth).

4.3.4.4.3 Gauge Repeatability and Reproducibility (GR&R) Protocol Appendix H contains a suggested GR&R protocol that may be used by the supplier and user to ensure that the respective wetting balance equipment are correctly calibrated.

4.3.5 Test F1 – Lead-free Solder – Wetting Balance Solder Pot Test (Leadless Components) This test is for wetting balance testing of leadless components.

4.3.5.1 Apparatus A solder meniscus force measuring device (wetting balance) which includes a temperature controlled solder pot containing solder per 3.2.1 and maintained per 3.5.1 and 3.5.2 **shall** be used. The equipment **shall** have a means of recording force as a function of time, such as a chart recorder, data logger, or computer (see Figure 4–9).

4.3.5.1.1 Dipping Device A mechanical or electromechanical dipping device incorporated in the wetting balance **shall** be used. The device **shall** be preset to produce an immersion and emersion rate as specified in 4.3.5.3. The specimen dwell time is controlled to the time specified in 4.3.5.3.

4.3.5.2 Preparation Specimen preparation **shall** be in accordance with 3.4.

4.3.5.3 Procedure

- a. Flux per 3.2.2 **shall** be used and **shall** be at ambient (room) temperature.
- b. Leads and terminations **shall** have flux applied uniformly and to cover the surfaces to be tested.
- c. Immerse and withdraw at 1 mm – 5 mm [0.04 in – 0.20 in] per second and dwell for 5 +0/-0.5 seconds. Massive components may require a longer solder dwell time (see 5.2).

- d. After application of the flux and post dip dwell, the specimen **shall** be mounted on the test equipment.
- e. Dross and burned flux **shall** be skimmed from the surface of the molten solder immediately before dipping.
- f. The flux covered termination **shall** be immersed only once in the molten solder to a depth of 0.10 mm [0.0039 in] minimum.
- g. The angle of immersion **shall** be per Figure 4–4.
- h. A full curve **shall** be recorded using the equipment specified in 4.3.5.1.

4.3.5.4 Evaluation

4.3.5.4.1 Magnification Parts **shall** be examined at 10X using the equipment specified in 3.3.3. For fine pitch termination parts (0.5 mm [0.020 in] pitch or less) the inspection magnification **shall** be 30X.

4.3.5.4.2 Accept/Reject Criteria Suggested criteria for solderability evaluation for Test F1 are listed in Table 4–5. Figures 4–10 and 4–11 illustrate the suggested criteria of Table 4–5. In addition, the area of the test sample with fresh solder adhesion **shall** be greater than the area that was immersed in the solder bath (i.e., the component **shall** exhibit positive wicking beyond its immersion depth).

4.3.5.4.3 Gauge Repeatability and Reproducibility (GR&R) Protocol Appendix H contains a suggested GR&R protocol that may be used by the supplier and user to ensure that the respective wetting balance equipment are correctly calibrated.

4.3.6 Test G1 – Lead-free Solder – Wetting Balance Globule Test This test is for lead-free solder wetting balance globule testing of components.

4.3.6.1 Apparatus A solder meniscus force measuring device (wetting balance) which includes a temperature controlled vertical, cylindrical iron shaft shrunk fit into an aluminum housing on which is placed a specific sized piece of solder. Examples are: a 200 mg piece of solder for a 4 mm diameter globule block, a 25 mg piece for a 2 mm globule block or a 6.25 mg piece for a 1 mm globule block. The molten solder globule should ideally be replaced after each solderability test, but may be re-used for very small components that do not remove more than 1% of the solder volume per solder test for up to 5 tests. The equipment **shall** have a means of recording force as a function of time, such as a chart recorder, data logger or computer.

4.3.6.1.1 Dipping Device A mechanical or electromechanical dipping device incorporated in the wetting balance **shall** be used. The device **shall** be preset to produce an immersion and emersion rate as specified in 4.3.6.3.3. The specimen dwell time is controlled to the time specified in 4.3.6.3.3.

4.3.6.2 Materials

4.3.6.2.1 Flux The flux used **shall** be in accordance with 3.2.2.

4.3.6.2.2 Solder The solder alloy **shall** be in accordance with 3.2.1. Other alloys may be used upon agreement between user and other parties.

4.3.6.2.3 Test Specimen The test specimen **shall** either be a full component or a lead that has been carefully removed from the component. Ideally the cross-section of the component to be dipped is either rectangular, square or round, to facilitate calculation of the theoretical maximum wetting force. Ideally no burr should be present but, if they are, generally they will be on the components used in production and should not be removed, as they may actually be the cause of the poor solderability. No cleaning of the specimen is allowed. Conditioning, if any, must be agreed to by the tester and other party, in advance.

4.3.6.3 Procedure

4.3.6.3.1 Temperature of the Solder The temperature of the solder is to be stabilized at the required temperature for the test before commencing the test. This temperature **shall** be per 3.5.1.

4.3.6.3.2 Fluxing A very small amount of flux is carefully applied to the surface or lead to be tested and the solder globule using a clean cotton tip or bud. No excess flux **shall** be ready to drip off the fluxed part or the excess flux must be drained off by carefully touching the lowest point on the surface to be tested with a piece of clean chemical lab filter paper. For this testing, ideally a small amount of flux should be kept in a small container that is only opened to immerse the cotton tip to wet it with flux. The cotton tips should be thrown away and replaced with fresh ones every 5 to 10 tests, with all tests done in the same testing interval. If testing is interrupted for more than a few minutes, then a new tip should be used.

4.3.6.3.3 Dipping Angle, Immersion Depth, and Immersion Rates The appropriate clip **shall** be chosen to hold the part as specified in Table 4–6 and illustrated in Figure 4–12. Without contaminating the surfaces to be tested, the specimen is mounted in the appropriate clip or other device supplied by the solderability tester manufacturer and carefully attached to the machine so as to not damage the transducer or dislodge the component from its orientation in the clip or other holder. The distance between the solderable surface of the sample and the solder globule should be fixed. An immersion speed between 1 mm/second and 5 mm/second [0.039 in/second and 0.20 in/second] should ensure that most test specimens are fully immersed. A dwell time of 5 seconds **shall** be used. A dwell time of 10 seconds may be necessary for large components or components with high thermal mass (see 5.2).

4.3.6.3.4 Preheat The decision to use preheat should be as agreed upon between the user and supplier, prior to testing.

4.3.6.4 Evaluation

4.3.6.4.1 Magnification Magnifications of up to 100X may be necessary, for example, to examine components smaller than 0402 chip components.

4.3.6.4.2 Suggested Criteria Prior to any post-test examination, all specimens **shall** have the flux removed using a cleaning agent in accordance with 3.2.3. The area of the test sample with fresh solder adhesion **shall** be greater than the area that was immersed in the solder globule, (i.e. the component **shall** exhibit positive wetting beyond its immersion depth). In addition, Table 4–7 lists suggested criteria.

5 NOTES

5.1 Use of Activated Flux This standard specifies a rosin-based flux with a very specific quantity of activator. The intent of requiring the use of a specific quantity of flux activator is to reduce the variability of test results that were seen with pure rosin flux, enable the solderability testing of non-tin component lead metallizations, and provide a realistic solderability testing safety factor by keeping the amount of activator both fixed and less than that used for production soldering. The benefit of using this specified activated solderability testing flux composition was demonstrated by extensive testing, as reported in the J-STD-002B Activated Solderability Test Flux Rationale Committee Letter.

5.2 Massive Components Large components that have terminations with high heat sinking capacity may require longer dwell times to be applied to the dip test (for example: Tests A, B, C, E and F) to allow for the slower heat up time. In such cases an agreement to increase the dwell time will be required between the user and vendor. This agreement must also state the specific dwell time to be used.

5.3 Sampling Plans Sampling plans **shall** identify the number of components to be randomly selected from a given lot. All leads/terminations of the components selected **shall** be tested for solderability. Each lead of a component must pass for the component to pass. The selection and disposition of solderability test specimens **shall** be per the individual component specification. It may be necessary to bend back one out of every two or two out of every three leads for some test methods. These leads would obviously not be counted.

5.4 Safety Notes Isopropyl alcohol is flammable. Care must be taken in both usage and storage to keep the isopropyl alcohol from sparks or flames. See the Material Safety Data Sheets (MSDS) for all solvents. All chemicals **shall** be handled per appropriate data sheets, and disposed of per local regulations.

5.5 Correction for Buoyancy For the wetting balance to obtain wetting force values that are relatable to one

another, it is necessary to correct for the variability in specimen sizes, in particular width and thickness. This is done by correcting for the volume of the sample immersed in the solder. The following formula may be used to calculate the buoyant force correction:

$$F_b = d (d_1 \text{ or } d_2) g_n V$$

where:

d_1 = Density of solder at 245°C (8150 kg/m³) for Sn60/Pb40 Alloy

d_2 = Density of solder at 255°C (7410 kg/m³) for SAC305 Alloy

g_n = Acceleration of gravity (9.810 m/s²)

V = Immersed volume in m³ (width x thickness x immersion depth)

The calculated buoyant force will be in Newtons and will be normalized for wetted perimeter and expressed as micro-Newtons/mm. As shown in Figures 4–10 and 4–11, using the convention that wetting force is positive upward, all measurements need to be buoyancy corrected for the times as well as the forces to be more accurate.

5.6 Accelerated Steam Conditioning Limitations The accelerated steam conditioning of solderable coatings has been, and continues to be, the subject of intense investigation (see IPC-TR-464). Compared to other conditioning methods, steam conditioning satisfactorily accelerates the degradation of tin and tin/lead surfaces in a manner similar to natural aging. The degradation mechanisms of surface oxidation and Cu/Sn intermetallic growth are both enhanced by the heat and humidity of steam. Properly applied tin and tin/lead coatings can withstand the steam conditioning environment well beyond the eight hours specified and may survive natural aging well beyond 12 months. Due to the combined effects of specific geometry, storage environment, and material systems, it is not possible to accurately predict storage life. As a result, this specification indicates a storage life overlap for coating durability Category 1 and Category 3, and an open-ended limit for coating durability Category 3. For coatings other than tin or tin-lead (Category 2), data do not exist to support steam conditioning longer than the one hour specified.

Appendix A Critical Component Surfaces

“J” Leaded Components

View 1

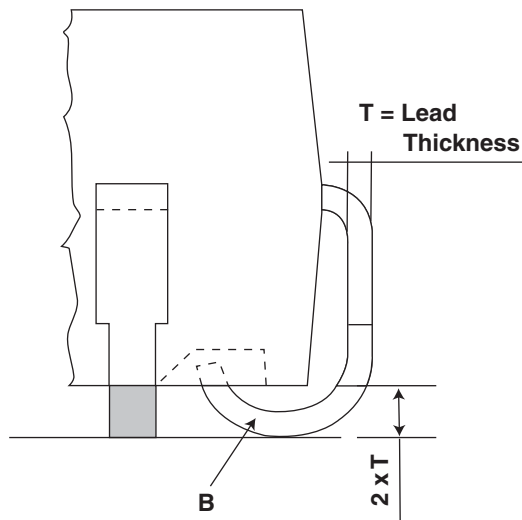

View 2

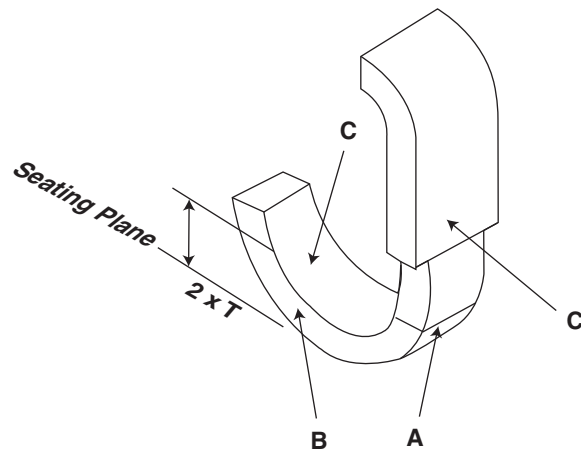

Critical Area = Surface “A” (Equal to 2 x Lead Thickness)

IPC-002c-a-1

Figure A-1 “J” Leaded Components

Passive Components

TESTS S and S1

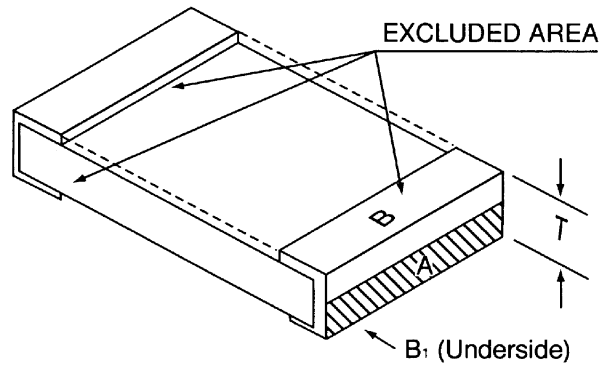

Critical Area = Surface "A" + "B₁" < 1/4 T or 0.5 mm whichever is less

TESTS B and B1

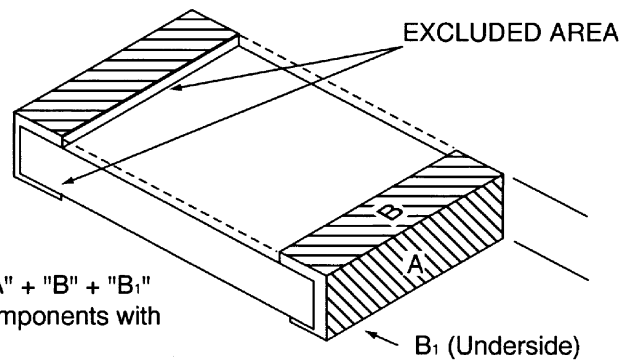

Critical Area = Surfaces "A" + "B" + "B₁"
Exclude surface "B" for components with "Top/Bottom" orientation

CYLINDRICAL

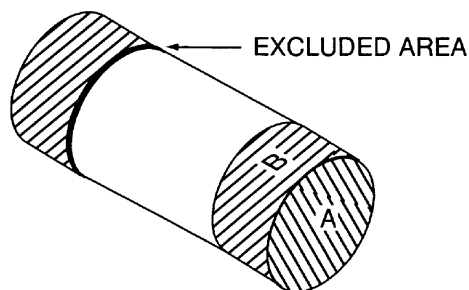

Critical Area = Entire end cap surface excluding inner rim

IPC-002c-a-2

Figure A-2 Passive Components

Gull Wing Components

View 1

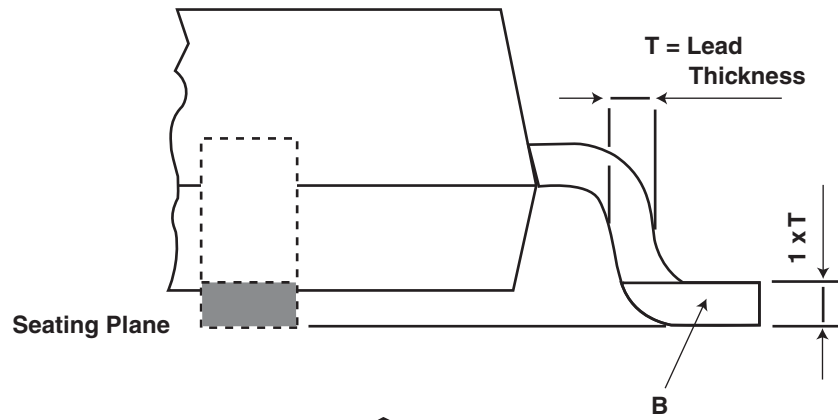

View 2

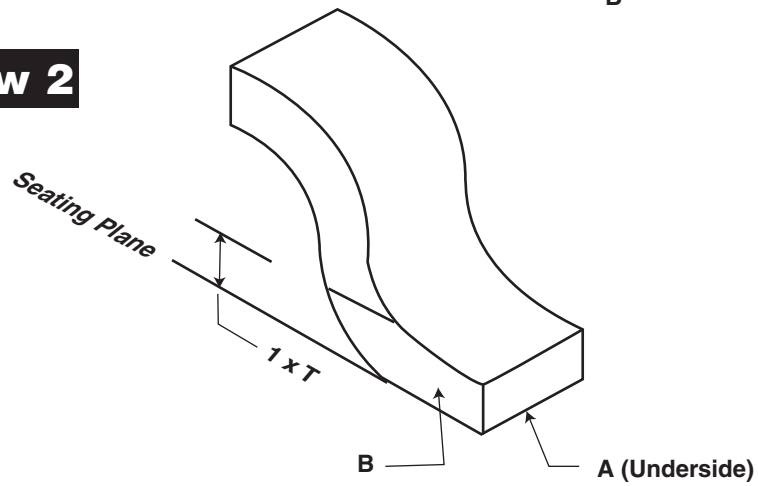

Critical Area = Surface "A" (Underside of Lead) up to 1 x T

IPC-002c-a-3

Figure A-3 Gull Wing Components

Leadless Chip Carrier LCC

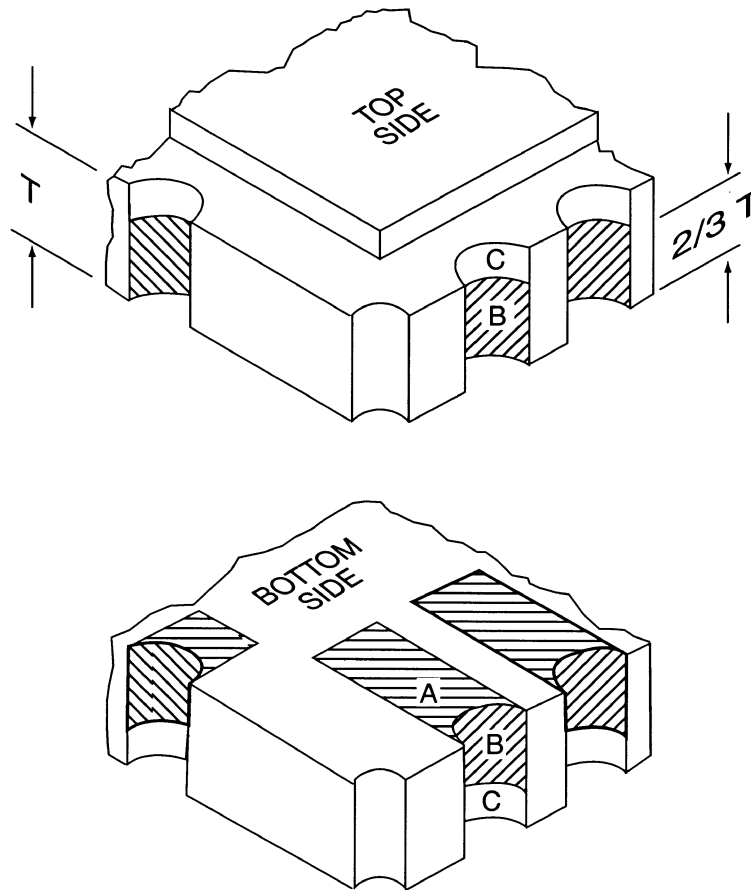

Critical Area = Total on contact pads "A" (on bottom side)
and $2/3$ of metallized connecting surface "B" and "C"

IPC-002c-a-4

Figure A-4 Leadless Chip Carrier

“L” Leaded Components

View 1

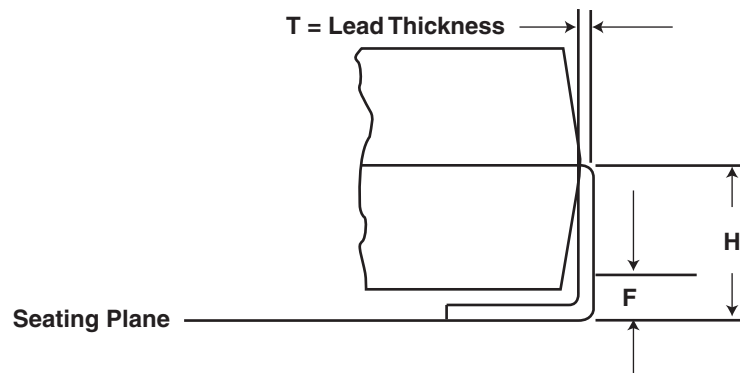

F = Minimum Fillet Height = The Lesser of:
 a) The solder fillet thickness on the underside of the lead + 0.25 x H or
 b) 0.5mm [0.0197in].

View 2

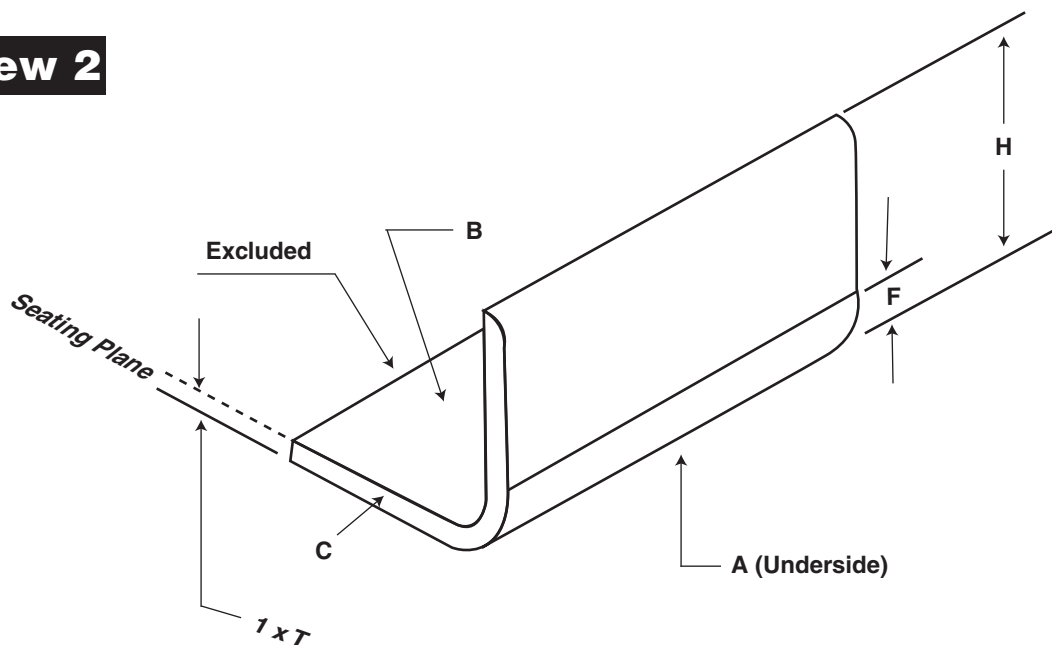

Critical Area = Surface “A” (Underside of Lead) up to 1 x T

IPC-002c-a-5

Figure A-5 “L” Leaded Components

Through-Hole Components

FLAT PIN

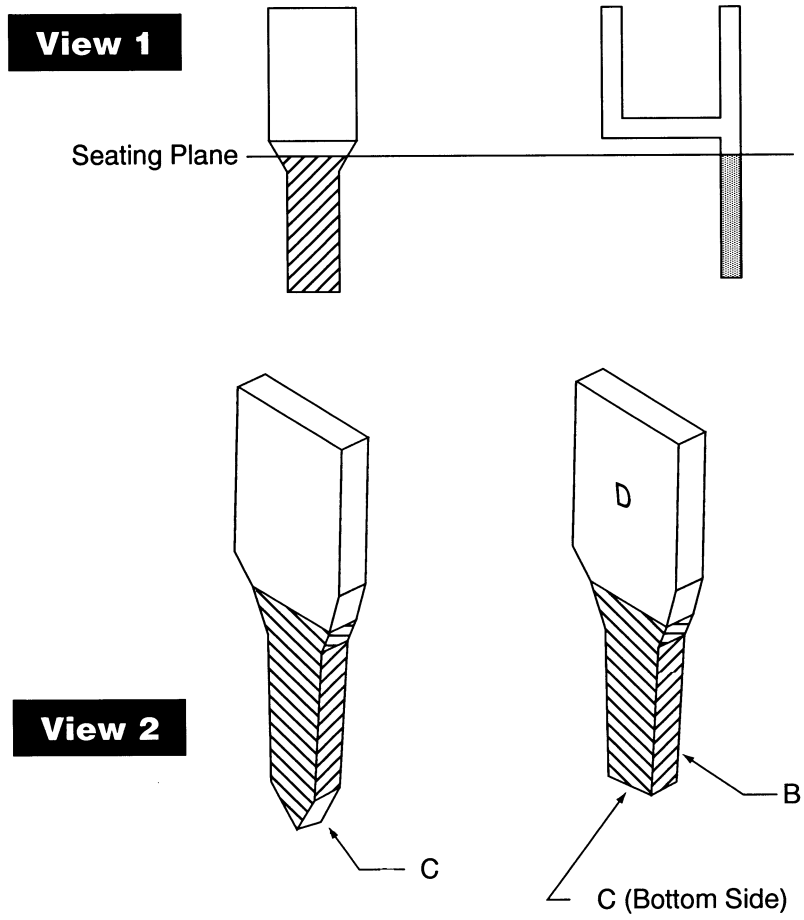

Critical Area = Surfaces "A", "B" (edges)
 or 1.27mm below bottom of
 package body if no standoff/
 seating plane

IPC-002c-a-6

Figure A-6 Through-Hole Components – Flat Pin

Through-Hole Components

ROUND PIN

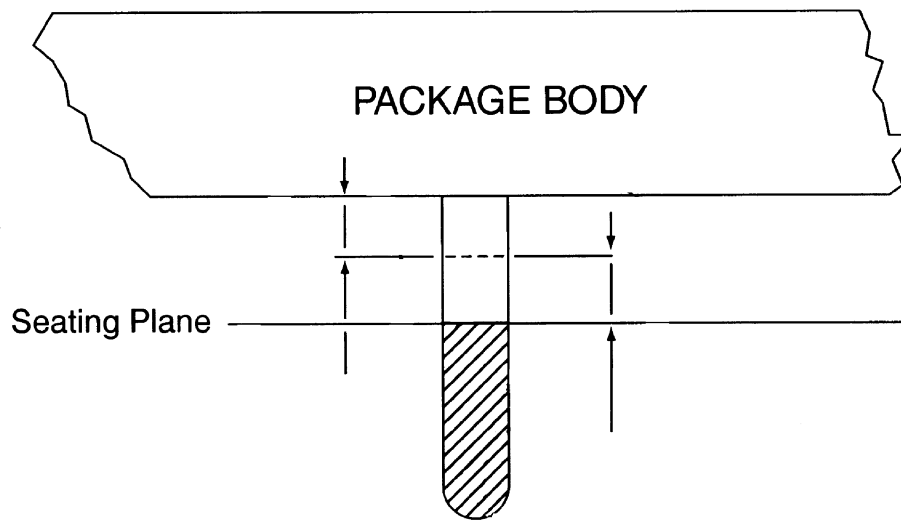

Critical Area = Entire surface of pin plus .75mm
above seating plane or 1.27mm
below bottom of package body
whichever is the smallest distance

IPC-002c-a-7

Figure A-7 Through-Hole Components – Round Pin

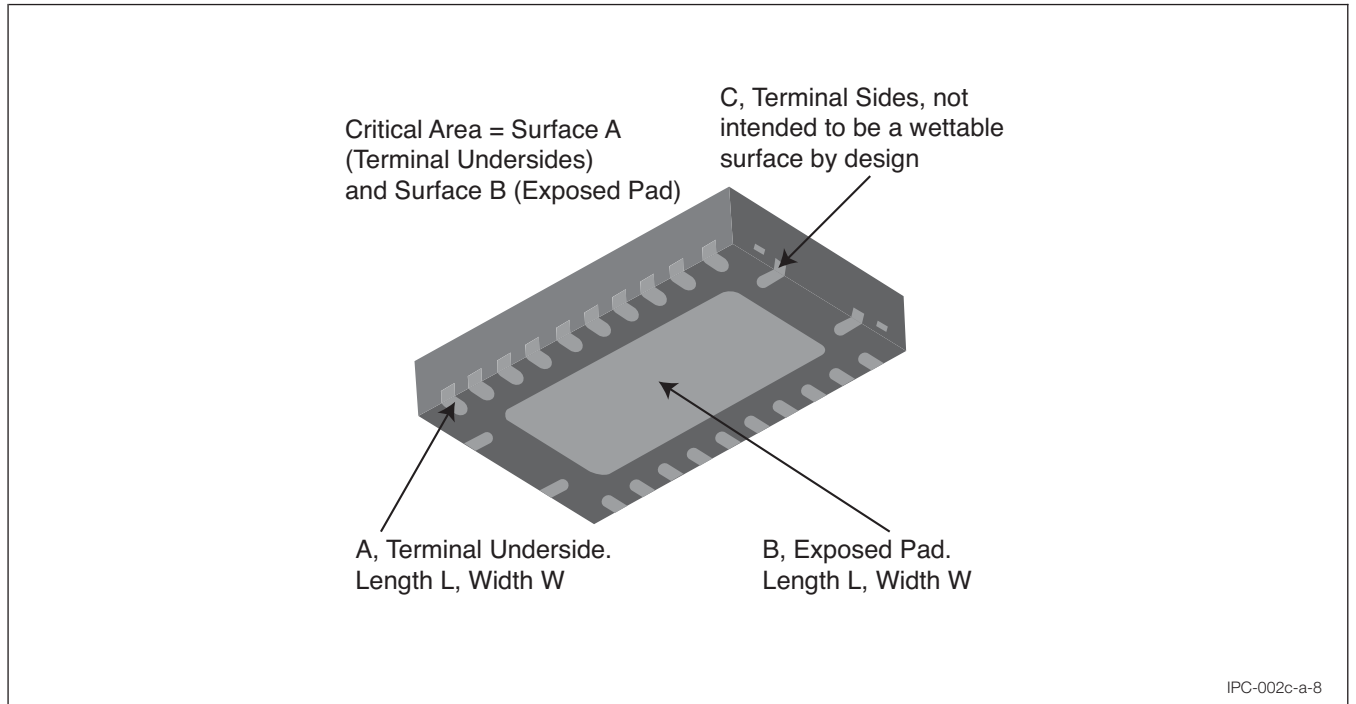

Figure A-8 Exposed Pad Package

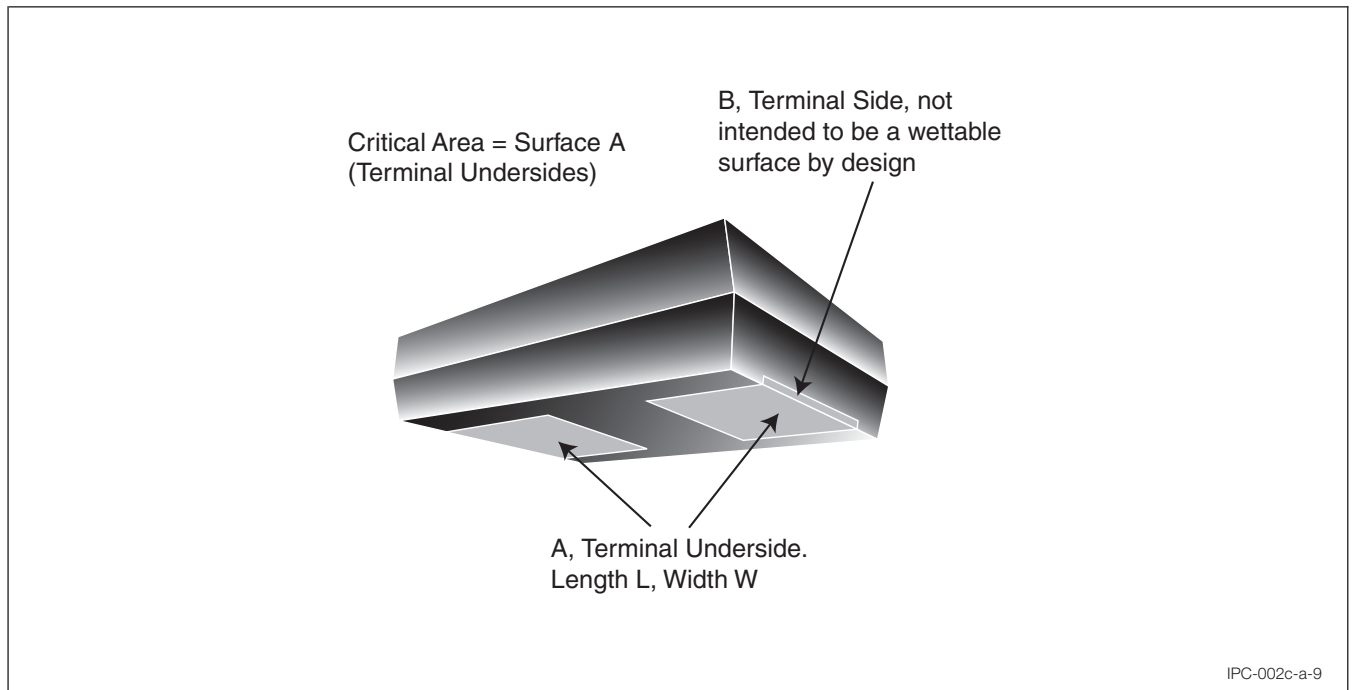

Figure A-9 Bottom-Only Termination Component

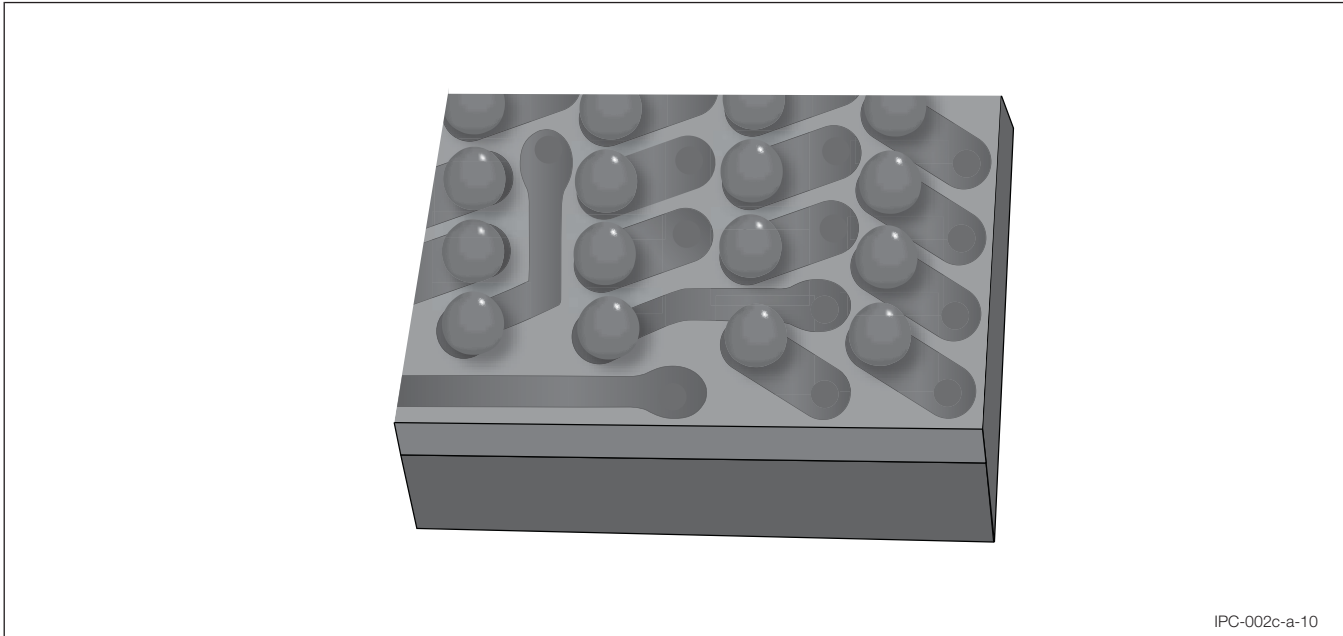

Figure A-10 Area Array Component Critical Surface

[Critical Surface: Each soldersphere **shall** have incorporated the solderpaste deposit (uniform, smooth solder with no dewetted areas)]. With Tests S and S1 – Surface Mount Process Simulation, the component leads **shall** be wetted in a consistent and unified manner, with no evidence of surface oxidation anomalies.

Appendix B Evaluation Aids

B.1 Evaluation Aids for Tests A, C, A1 and C1

B.2 Round Leads The measurement of defects or the estimation of defect area percentage of the lead total surface area, is more difficult with round leads than it is with flat surface rectangular leads. For example, in viewing a cylindrical surface such as a round lead, a round diameter-sized defect when flat appears oval shaped and narrower in width than the visible surface of the lead in the transverse direction, which is half of its circumference.

To aid the solderability test inspector in estimating the lead surface percentage after solderability testing, a guide sheet for different diameter leads is shown in Figure B-3. When 25.4 mm [1.0 in] of the lead surface of a 0.5 mm [0.02 in] diameter lead is inspected for solder coverage, 10 diameter size defects equal 5% of the total lead surface area. Numbers of half diameter size and quarter diameter

size defects are also listed. Combinations of these sizes can also be totaled easily (see Figure B-1).

In considering areas not covered by a continuous, new solder coating and referring to the defined defects illustrated in Figure B-2, the visible areas of dewetting and nonwetting are applicable directly.

An example of what constitutes 5% of the dipped area is: six defects of 0.813 mm [0.032 in] diameter in a 25.4 mm [1.0 in] length of a 0.813 mm [0.032 in] diameter (No. 20 AWG) wires (see Figures B-3, B-4 and B-5).

B.3 Square Terminations Square terminations shall meet the requirements of the solderability coverage guide shown in Figure B-5.

B.4 Castellated Terminations Castellated terminations shall meet the same criterion as round leads.

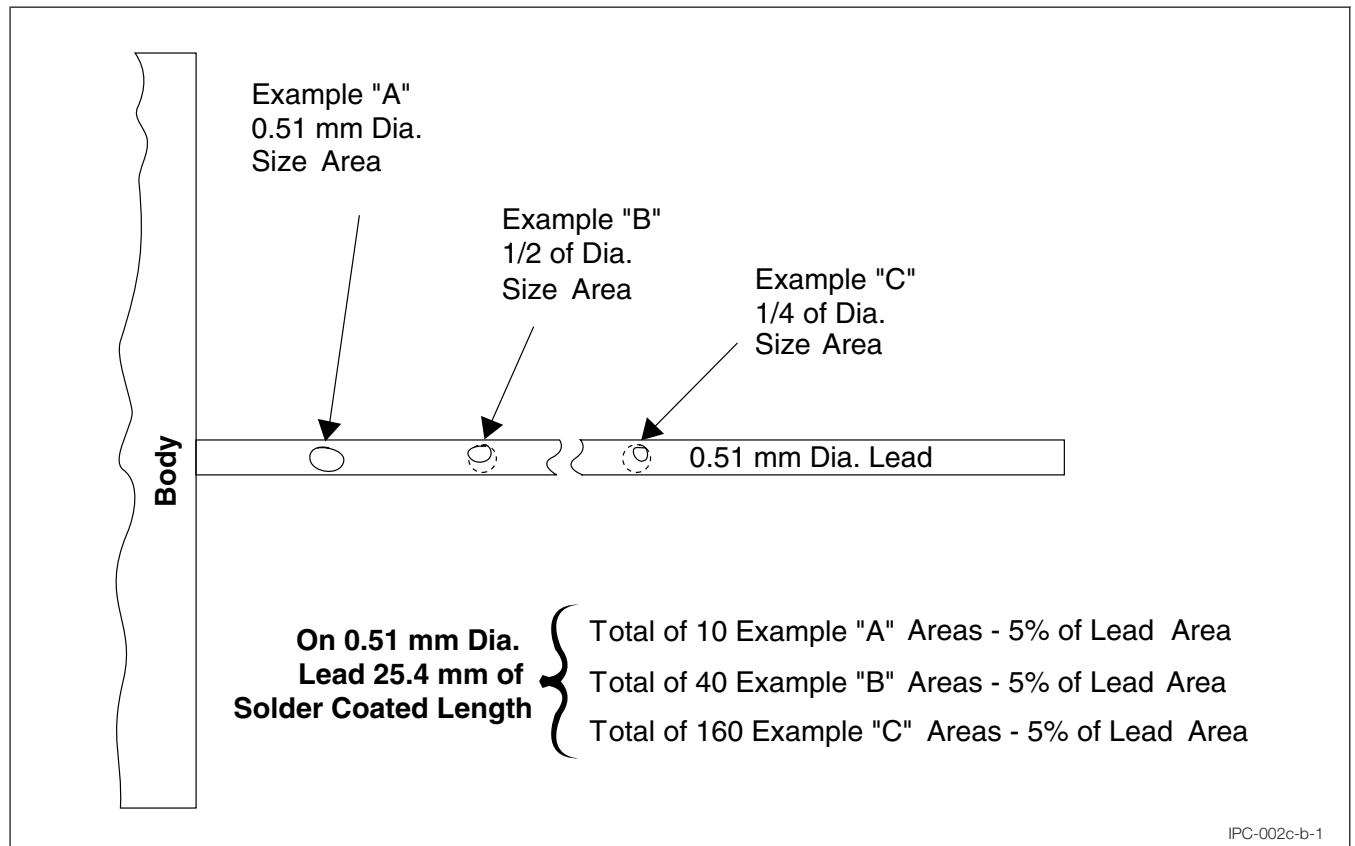

Figure B-1 Defect Size Aid

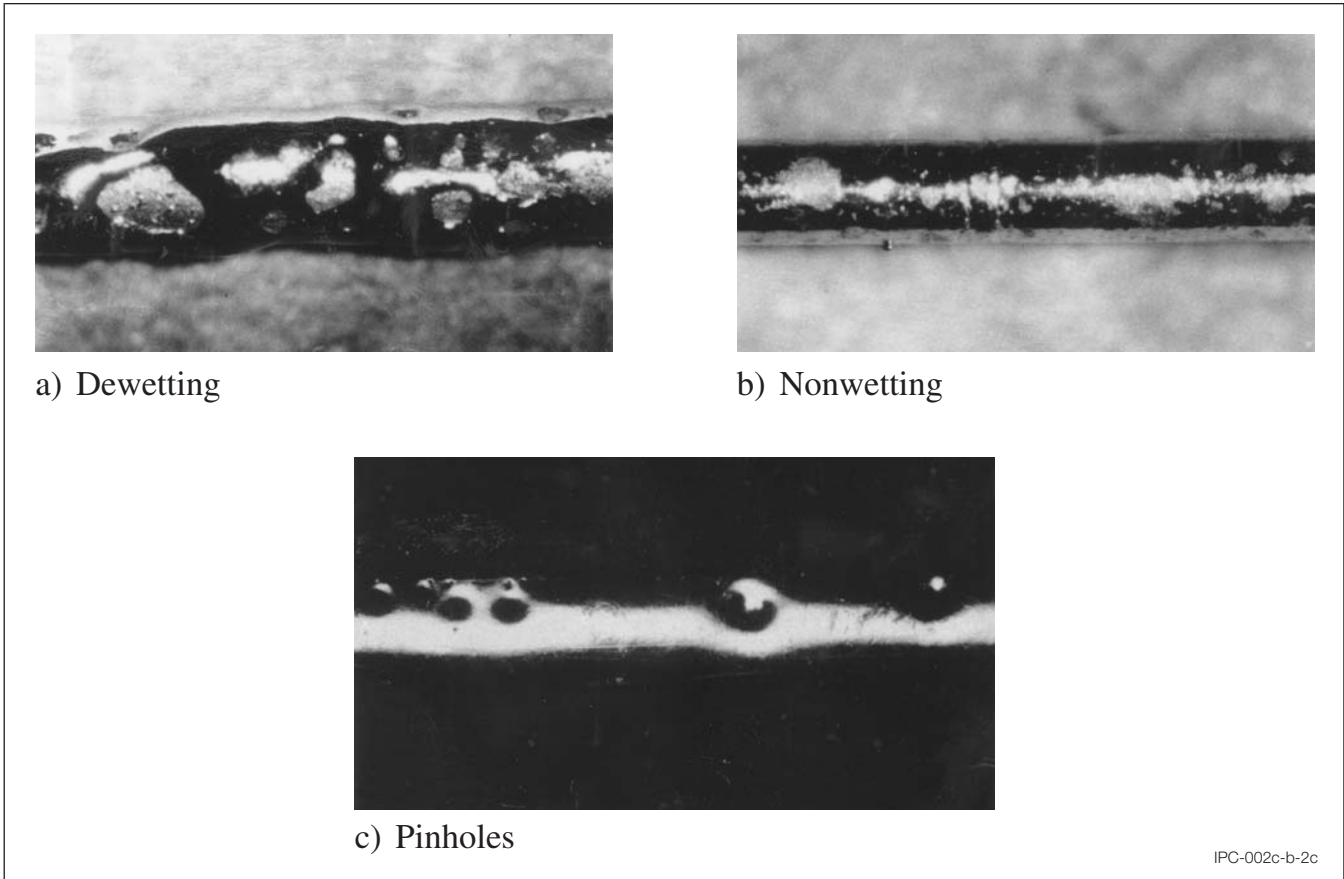

Figure B-2 Types of Solderability Defects

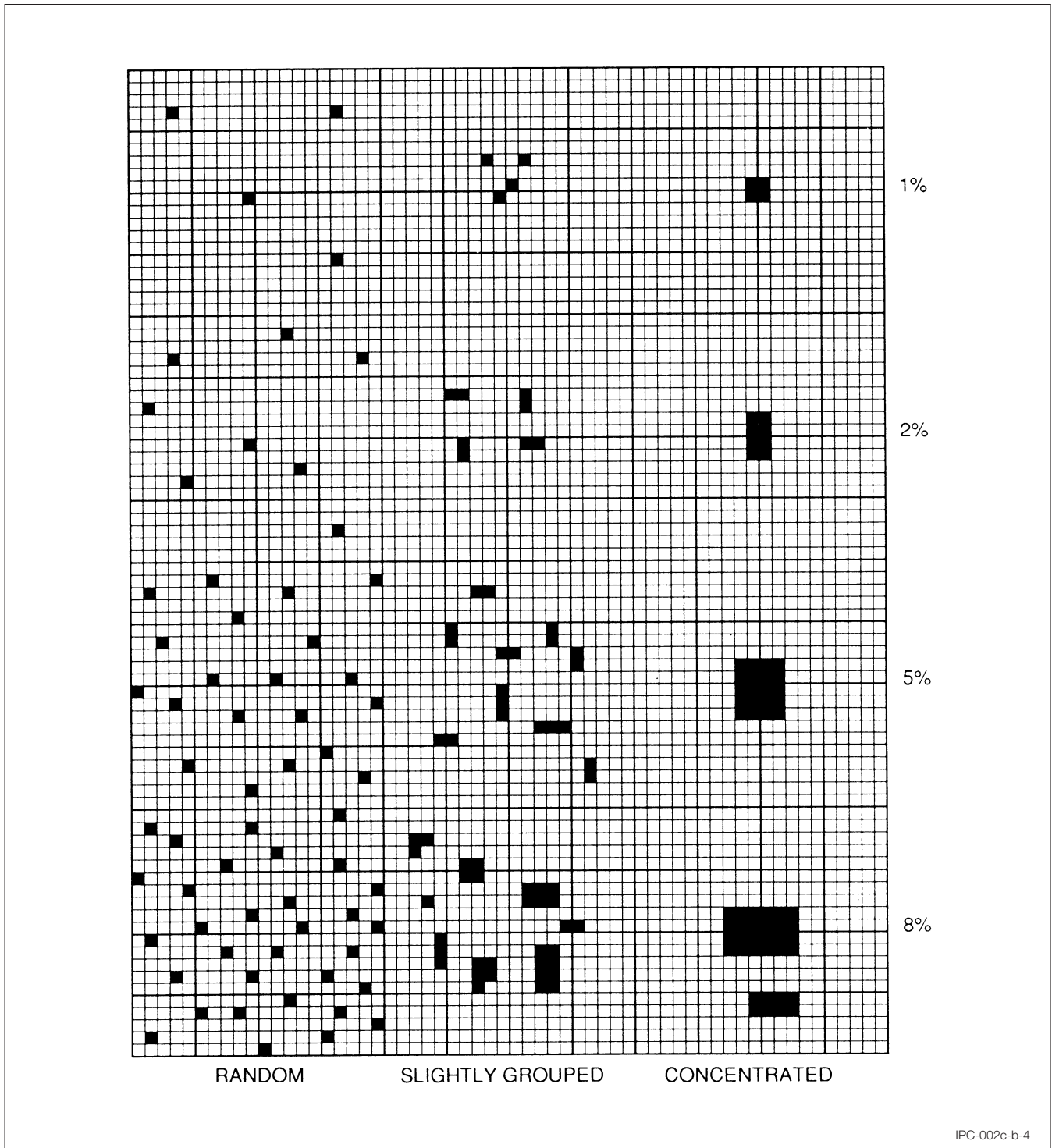

Figure B-4 Aid in Evaluation of 5% Allowable Area of Pin Holes

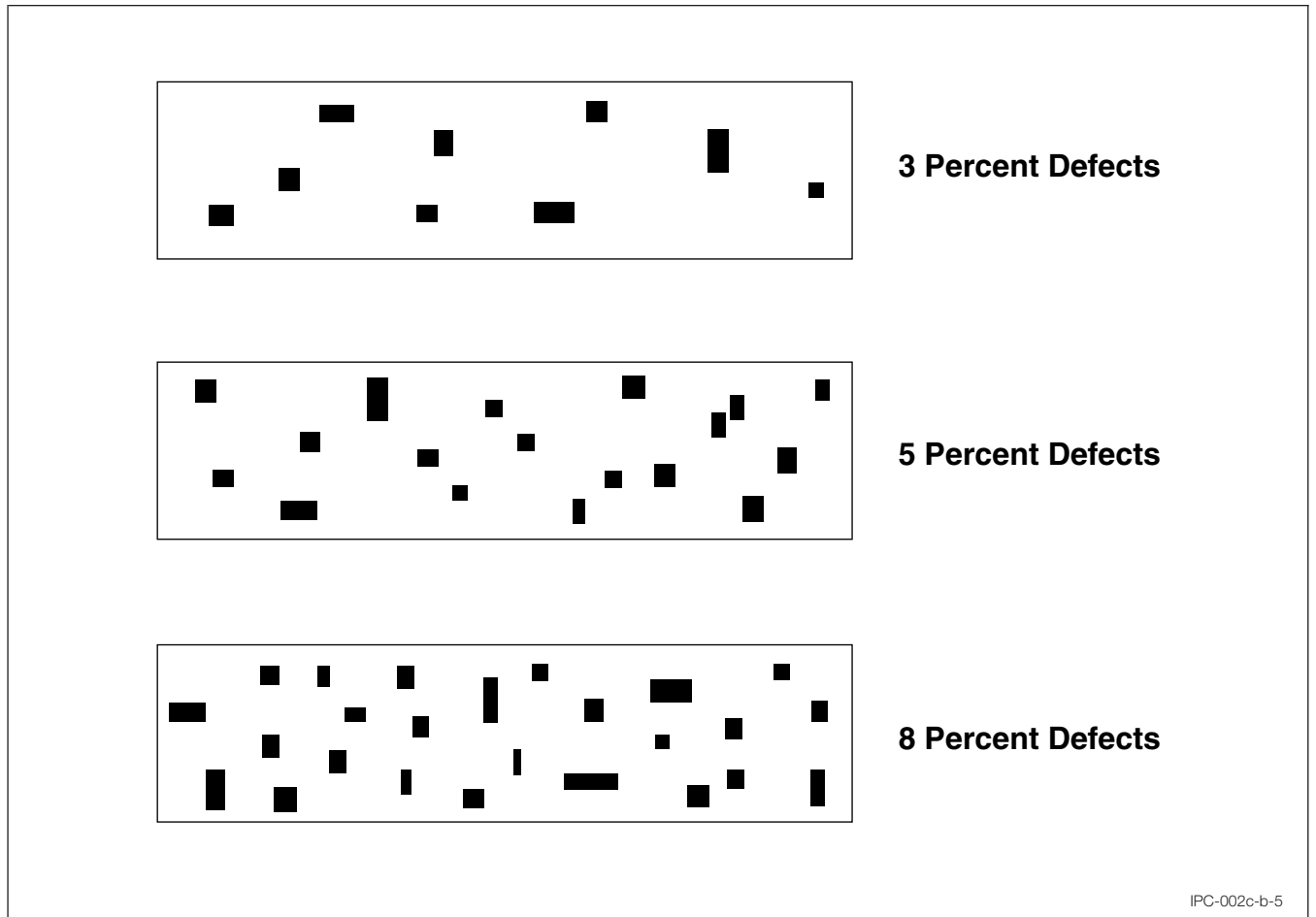

Figure B-5 Solderability Coverage Guide

Appendix C

Calculation of Maximum Theoretical Force

Maximum theoretical force is calculated using the procedure of Klein Wassink.¹

$$\text{Force (Max. Theoretical)} = (\gamma) (P) (\cosine \beta) - (d)(g) (V) = [0.4P - 0.08V] \text{ mN}$$

where:

P = the perimeter of the test specimen in millimeters, i.e., the length in millimeters of the solder/printed board or coupon pad (or hole)/air interface as measured at maximum depth of immersion.

V = The volume in cubic millimeters of the test specimen that resides below the solder/board air interface as measured at the maximum depth of immersion.

γ = Surface tension of solder = 0.4 mN/mm

γ = Surface tension of Pbfree solder = 0.5 mN/mm

α = Immersion angle of the board to the horizontal surface, i.e., $\alpha = 45^\circ$

β = Wetting angle of solder to the board under optimal conditions, i.e., $\beta = 0$ and therefore the cosine $\beta = 1$

d = Density of solder at 235°C, = 8120 kg/m³ for Sn60/Pb40 Alloy

d = Density of solder at 255°C = 7410 kg/m³ for SAC305 Alloy

g = Gravitational constant = 9.8 x 10³ mm/s²

Periphery and volumes are to be calculated using the nominal values provided by the device supplier in the package drawing and the angles and depths of immersion as described in the specification above. The TOTAL periphery and volume, i.e., the sum of all leads being immersed, is to be used in this calculation.

Figure C-1 depicts a sample calculation for 132 I/O QFP.

Where:

w = Lead width (nominal) = 0.254 mm

t = Lead height (nominal) = 0.1524 mm

d = Immersion depth = 0.3 mm

l = Lead length immersed on bottom side at 20° angle and 0.3 mm depth = 0.877 mm

m = Lead length immersed on top side at 20° angle and 0.3 mm depth = 0.458 mm

k = Length of solder/lead/air interface along lead side = 0.446 mm

2k + 2w = Total length per lead of solder periphery = 0.892 + 0.508 = 1.4 mm

P = Total length of periphery per side (33 leads) = 46.2 mm

Hence:

Total volume immersed per lead = 0.254 X 0.1524 X 0.458 + 0.5(0.1524 X 0.254 X 0.419) = 0.0177 + 0.0081 = 0.0258 mm³

Therefore for an 132 I/O QFP, the maximum theoretical wetting force is:

For 33 leads (one side of an 132 I/O QFP) = 33 x 0.0258 mm³ = 0.85

Maximum Force = (0.4 x 46.2) - (0.08 x 0.85) = 18.41 mN

And, for a part of 46.2 mm total periphery:

Maximum Force per length of interface = 399 μN/mm

The force measured on a part in the Set A criteria must therefore be greater than 9.2 mN or 200 μN/mm at F2.

Note: All forces are referenced to the corrected zero axis and not the zero force line except for the Appendix D calculation (parameter AA).

1. R. J. Klein Wassink, "Soldering in Electronics," 2nd Edition, Electrochemical Publications, Ayr, Scotland, 1989, pp 308-309

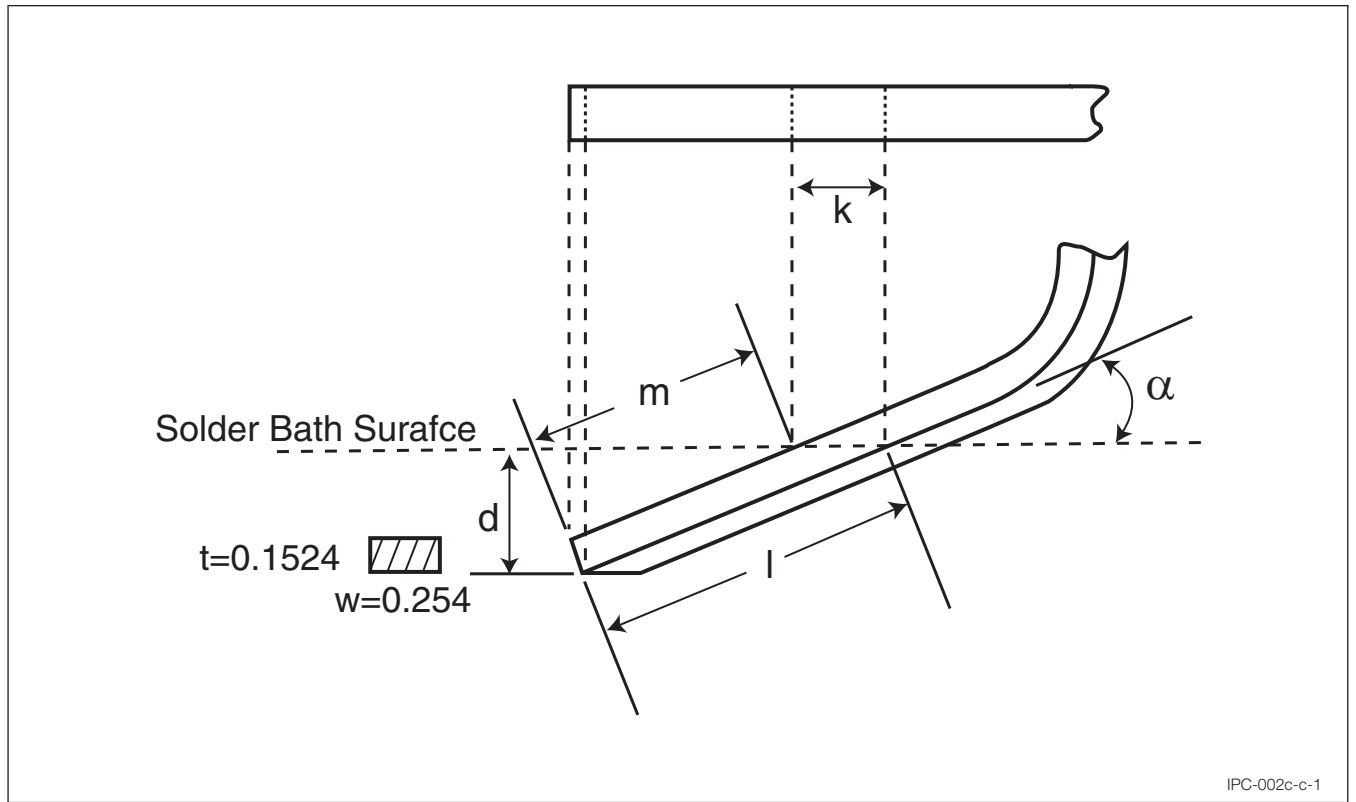

Figure C-1 Lead Periphery and Volume for a 132 I/O PQFP

Appendix D

Calculation of Integrated Value of Area of the Wetting Curve

The area is calculated using the maximum theoretical force (see Figure 4.18 or 4.19). Therefore, the area is given as:

$$\text{Area} = \text{Wetting force} \times \text{time} - \text{Buoyancy} \times \text{time}$$

$$\text{Area} = (3.0 \text{ sec.} \times \text{Max. Theoretical Force}) - 2.0 \text{ sec} (\rho) (g) V$$

$$\text{Area} = (3.0 \text{ sec.} \times \text{Max. Theoretical Force}) - 2.0 \text{ sec} \times (8.12 \times 10^{-6} \text{ kg/mm}^3 \times 9.8 \times 10^3 \text{ mm/s}^2 \times V)$$

The value V is the volume of the test specimen immersed in the solder bath as calculated in Appendix C. The maximum theoretical force is calculated as per Appendix C. The following assumptions are made:

1. The maximum buoyancy force holds for the whole two (2) seconds contributing a negative area of: the buoyancy force times two (2) seconds.

2. The test specimen essentially attains the full maximum theoretical force as it crosses the zero line at two (2) seconds and holds that value for the duration of the test, i.e., three (3) seconds.

$$V = \text{Total Volume} = 0.4 \text{ mm}^3$$

$$\text{Maximum Theoretical Force: } 3.97 \text{ mN}$$

$$\text{Area} = (3.0 \text{ sec.} \times 3.97 \text{ mN}) - (2.0 \text{ sec.} \times 0.08 \text{ (kg/mm}^3 \times \text{mm/s}^2) \times 0.4 \text{ mm}^3) = 11.91 \text{ mN} \times \text{seconds} - 0.064 \text{ (kg-mm/sec)}$$

$$\text{Since } F = ma, \text{ then } \text{mN} = \text{kg} \times \text{mm/sec}^2 \text{ or } \text{kg} = \text{mNsec}^2/\text{mm}$$

$$\text{Area} = 11.91 \text{ mN} \times \text{seconds} - 0.064 \text{ (mNsec}^2/\text{mm}) \times (\text{mm/sec})$$

$$\text{Area} = 11.91 \text{ mN} \times \text{seconds} - 0.064 \text{ mN} \times \text{seconds}$$

$$\text{Area} = 11.85 \text{ mN} \times \text{seconds}$$

Appendix E Informative Annex

E.1 Test Equipment Sources The equipment sources described below represent those currently known to the industry. Users of this document are urged to submit additional source names as they become available, so that this list can be kept as current as possible.

E.1.1 Tests A, B, C, D, A1, B1, C1, D1

GEN3 Systems Limited (Formerly Concoat Systems) Unit B2, Armstrong Mall, Southwood Business Park, Farnborough, Hampshire GU14 0NR England. 011 44 12 5252 1500 www.gen3systems.com

HMP Soldermatics, P.O. Box 948, Canon City, CO 81215, (719) 275-1531

Malcomtech 26200 Industrial Blvd, Hayward CA 64545, (510)293-0580, www.malcomtech.com

Reef Engineering, Unit 6, Bancrofts Road, South Woodham Ferrers, Essex CM3 5UQ 01245 328123

Robotic Process Systems Inc., 23301 E. Mission Ave., Liberty Lake, WA 99019, (509)891-1680

E.1.2 Tests E, F, E1 & F1

Convey AB, Harpsundsvagen 113, S-12458 Bandhagen, Sweden 46 (0) 8 99 66 25

GEN3 Systems Limited (Formerly Concoat Systems) Unit B2, Armstrong Mall, Southwood Business Park, Farnborough, Hampshire GU14 0NR England. 011 44 12 5252 1500 www.gen3systems.com

Malcomtech 26200 Industrial Blvd, Hayward CA 64545, (510) 293-0580, www.malcomtech.com

Metronelec, 54, Route de Sartrouville – Le Montreal 78232 Le PECO Cedex, France (USA Distributor: Solderability Testing and Solutions Inc., 18 Wildrose Dr., Edgewood, KY 41017, (859) 331-0598, www.wettingbalance.com

Robotic Process Systems Inc., 23301 E. Mission Ave., Liberty Lake, WA 99019, (509)891-1680

E.1.3 Tests G & G1

GEN3 Systems Limited (Formerly Concoat Systems) Unit B2, Armstrong Mall, Southwood Business Park, Farnborough, Hampshire GU14 0NR England. 011 44 12 5252 1500 www.gen3systems.com

Metronelec, 54, Route de Sartrouville – Le Montreal 78232 Le PECO Cedex, France (USA Distributor: Solder-

ability Testing and Solutions Inc., 18 Wildrose Dr., Edgewood, KY 41017, (859) 331-0598, www.wettingbalance.com

E.1.4 Steam Conditioning Equipment

H&H Engineering, Inc., 3612 Wood Duck Circle, Stockton, CA 95206

Metronelec, 54, Route de Sartrouville – Le Montreal 78232 Le PECO Cedex, France (USA Distributor: Solderability Testing and Solutions Inc., 18 Wildrose Dr., Edgewood, KY 41017, (859) 331-0598 www.wettingbalance.com

Mountaingate Engineering Inc., Campbell, CA 95008, (408) 866-5100

Robotic Process Systems Inc., 23301 E. Mission Ave., Liberty Lake, WA 99019, (509) 891-1680

Zentek Scientific Systems, 3520 Yale Way, Fremont, CA 94538, (510) 651-1581

E.1.5 Grid Reticles

Bender Associates, 5030 South Mill Avenue, Suite C-2, Tempe, AZ 85252, (602) 820-0900

E.2 Test Flux Product Sources The Test Flux product sources described below represent those currently known to the industry. Users of this document are urged to submit additional product source names as they become available, so that this list can be kept as current as possible.

AIM Solder {www.aimsolder.com} – Standard Flux #1 Product ID: RMA 202-25

Alpha Metals {www.alphametals.com} – Standard Flux #2

GEN3 Systems Limited {www.gen3systems.com} – Product ID's: SMNA – Standard Flux #1: Actiec 2 / – Standard Flux #2: Actiec 5

Kester {www.kester.com} – Standard Flux #1 Product ID: 182

Qualitek International, Inc. {www.qualitek.com} – Standard Flux #1 Product ID: 285-25

Solderability Testing and Solutions Inc. {www.wettingbalance.com} – Standard test flux 0.2% and Standard test flux 0.5%

Appendix F

J-STD-002/J-STD-003 Activated Solderability Test Flux Rationale Committee Letter

The current J-STD-002/J-STD-003 specification includes a departure in the test flux methodology used in past solderability testing. The table in paragraph 3.2.2 Flux is:

Table 3-1 Flux Compositions

Constituent	Composition by Weight Percent	
	Flux #1	Flux #2
Colophony	25 ± 0.5	25 ± 0.5
Diethylammonium Hydrochloride (CAS 660-68-4)	0.15 ± 0.01	0.39 ± 0.01
Isopropyl Alcohol (IPA) (CAS 67-63-0)	Balance	Balance
Weight of Chlorine as % of Solids	0.2	0.5

The J-STD-002/J-STD-003 committees understood that any proposed change to the use of ROL0 (formerly designated type R) would be heavily scrutinized and would require test data showing the applicability of using a standard activated flux composition. The J-STD-002/J-STD-003 committees have spent significant resources working this flux change issue, discussing the chemistry details and conducting multi-company Design of Experiment investigations. The J-STD-002 committee chairmen, Dave Hillman [Rockwell Collins], Doug Romm [Texas Instruments], Mark Kwoka [Intersil] and Jack McCullen [Intel], feel that the committee has compiled a significant data set and have held thorough topic discussions supporting the proposed flux material change. The four rationales for proposing/supporting the flux change are summarized below:

1) A Proactive Solderability Testing Approach to The Implementation of Non-Tin Finishes

A number of industry studies (1996 NEMI Surface Finishes Task Group Report, 1997 NCMS Lead-Free Solder Project, 2000 National Physical Laboratory CMMT (A) 284 Report) have shown that an incompatibility of “R type” flux with non-tin surface finishes such as palladium, organic solderability preservatives (OSPs), and immersion gold. The introduction of these various metallic surface finishes on components and printed wiring boards is no longer the exception but has/is quickly becoming the norm. The use of a “R type” flux containing only naturally occurring activators has resulted in producing “false negative” solderability test results which impact both the component/board fabricator and the assembler negatively in terms of cost and schedule.

2) Reduced Solderability Test Variability

The J-STD-002/003 solderability committees enlisted the assistance of Dr. Carol Handwerker and the resources of the National Institute of Standards & Technology (NIST) to investigate/compare a standard activated flux composition versus the “R type” flux composition. A detailed statistical analysis by Bill Russell, Raytheon Systems, and NIST statisticians revealed the use of a standard activated flux composition greatly reduced the amount of solderability test variation. One of the major goals of the J-STD-002/003 solderability committees is to develop test methods and standards which promote consistency across the industry.

3) Concerns of a Loss of Solderability Assessment Safety Margin

The two major historical rationale for using an “R type” flux: 1) colophony or rosin contains only naturally occurring flux activator constituents and thus is not subjected to the problems/complications of chemistry formulas by the flux supplier; 2) it was an accepted industry acknowledged fact that, if a component or printed wiring board surface was found to have acceptable solderability test results using “R type” flux, then the more active flux formulations used in the assembly process would produce acceptable solder process results. This solderability assessment safety margin was a self imposed, industry consensus decision. The J-STD-002/003 committees understood the historical relevance behind the decision to use “R type” flux and had an equally strong desire to maintain a solderability assessment safety cushion. However, committees fielded a number of industry inputs to reassess the solderability flux composition based on the technology improvements in surface finishes, improvements in the flux chemistry formulations from flux suppliers, and the desire to not have excessive safety margins which would impact cost and schedule in a non-value added manner. The committees conducted a number of tests (Wenger, Kwoka, ACI) demonstrating, using a specific standard level of activation on real world, industry supplied component and printed wiring board cases, that the occurrence of a “false acceptable” solderability test result was extremely low. There was no case that exhibited a “pass ROL1 test – fail ROL0 test – Fail during board assembly” sequence. In fact, the use of both ROL1 and ROL0 are more likely to create a “false reject” “dip and look solderability test result when compared to board level soldering performance.

4) Standardization of Solderability Test Flux Composition on a Global Scale

A second major goal of the J-STD-002/003 solderability committees is to develop test methods and standards which promote global standardization for the electronics industry. The standard activated flux composition selected and tested by the committees has been utilized in the International Electrotechnical Commission (IEC) 60068-2-20 Soldering specification. The IEC specification is successfully utilized for solderability testing. Having

compatibility of flux composition requirements between the J-STD-002/003 specification and the IEC specifications is a win-win situation for electronics assemblers and component/printed wiring board fabricators.

A number of the major flux chemistry suppliers have been queried on the electronics industry's ability to purchase the standard activated flux composition, and a positive response was received. If you have any questions please contact the IPC Technical Staff to obtain additional answers/clarification.

Appendix G
Graphical Representations: Progression of Solder Wetting
Curve Parameters As Measured By Wetting Balance Testing

Understanding Wetting Curves

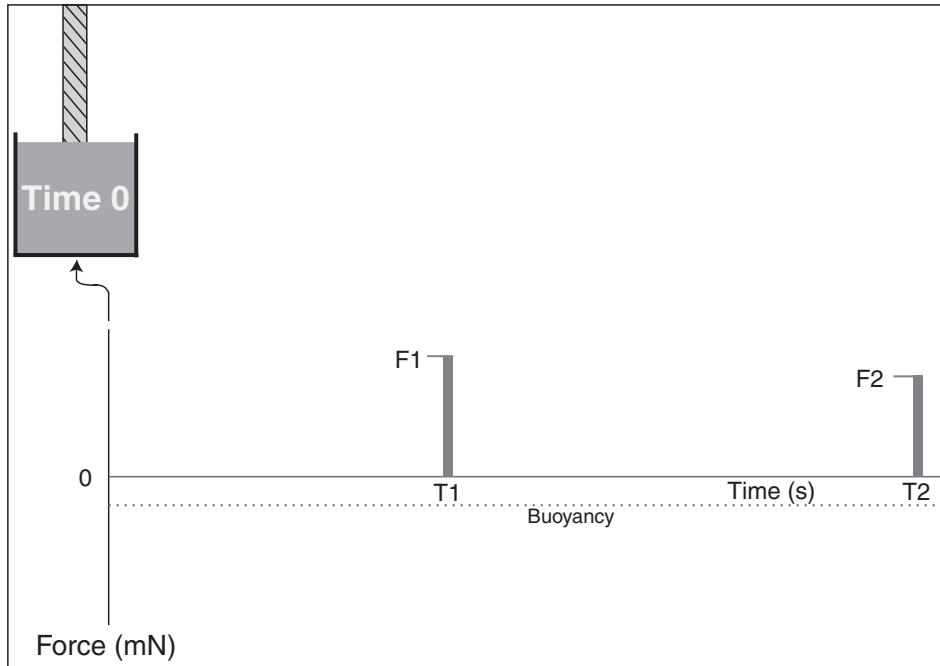

Understanding Wetting Curves

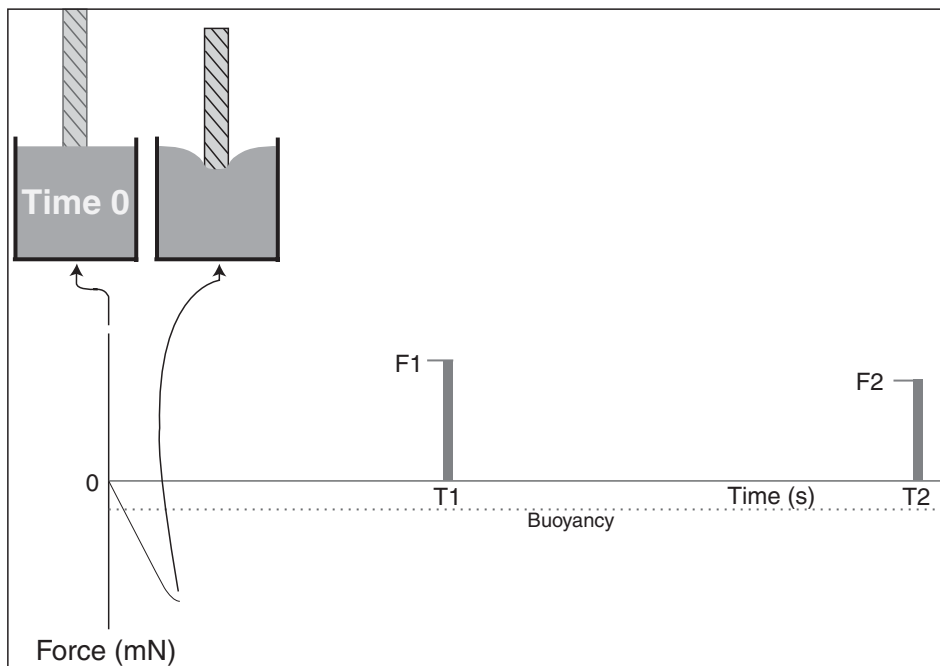

Understanding Wetting Curves

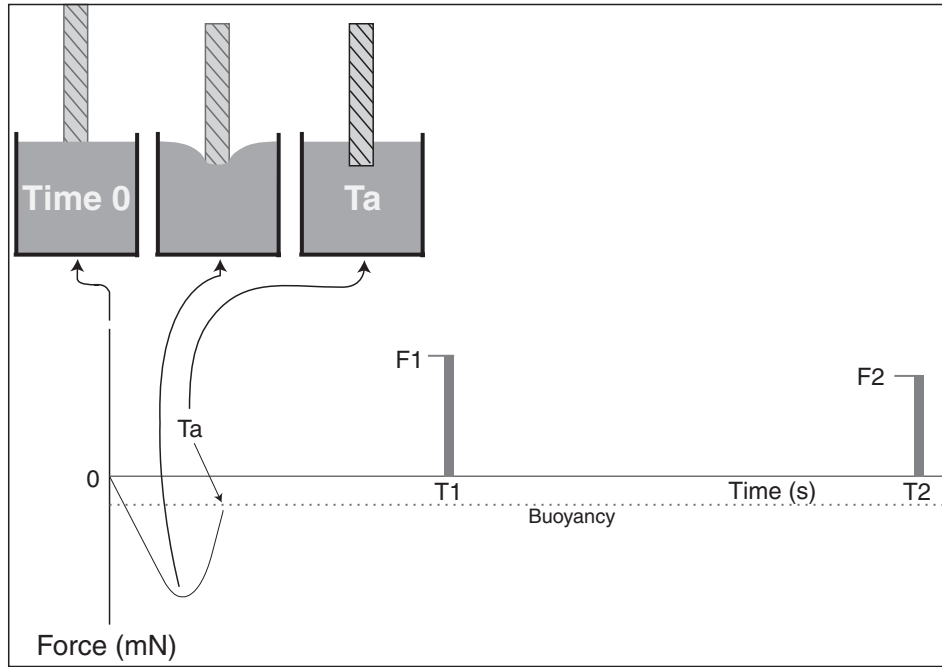

Understanding Wetting Curves

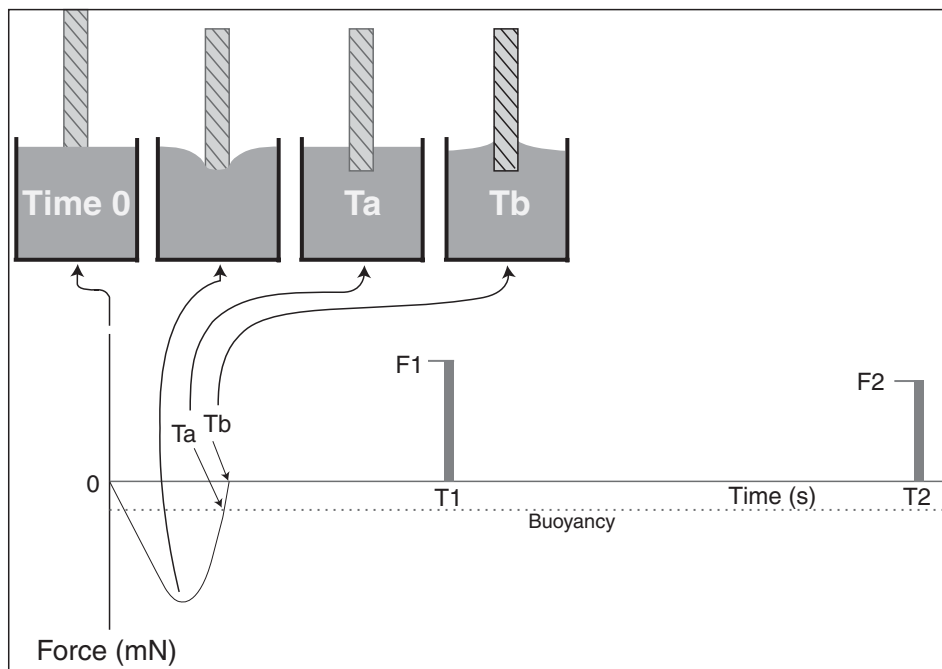

Understanding Wetting Curves

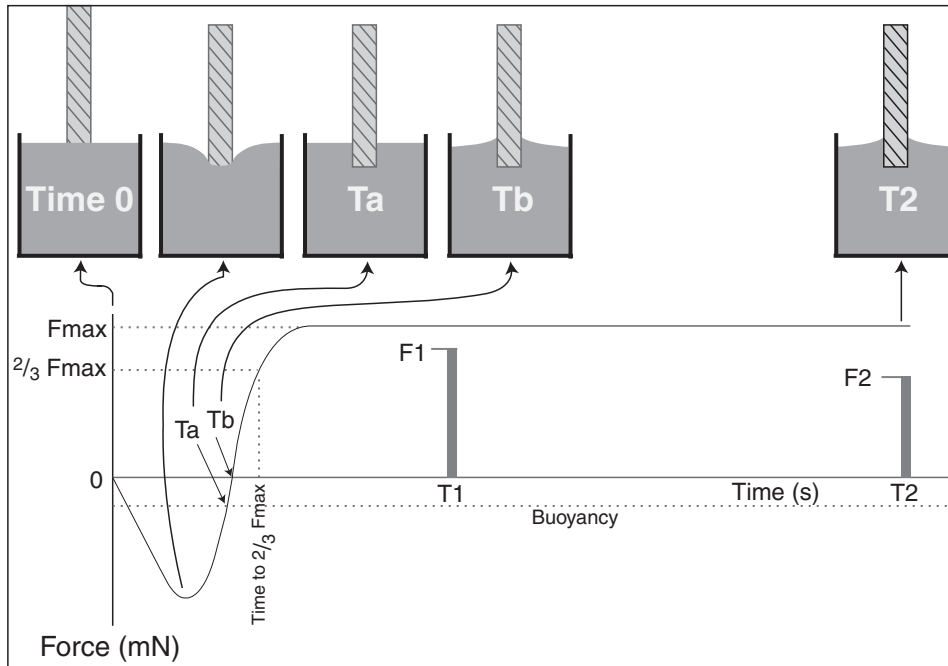

The net of the parameters measured from the progression of the five steps encountered during the wetting balance testing, as highlighted above:

Typical Wetting Curve

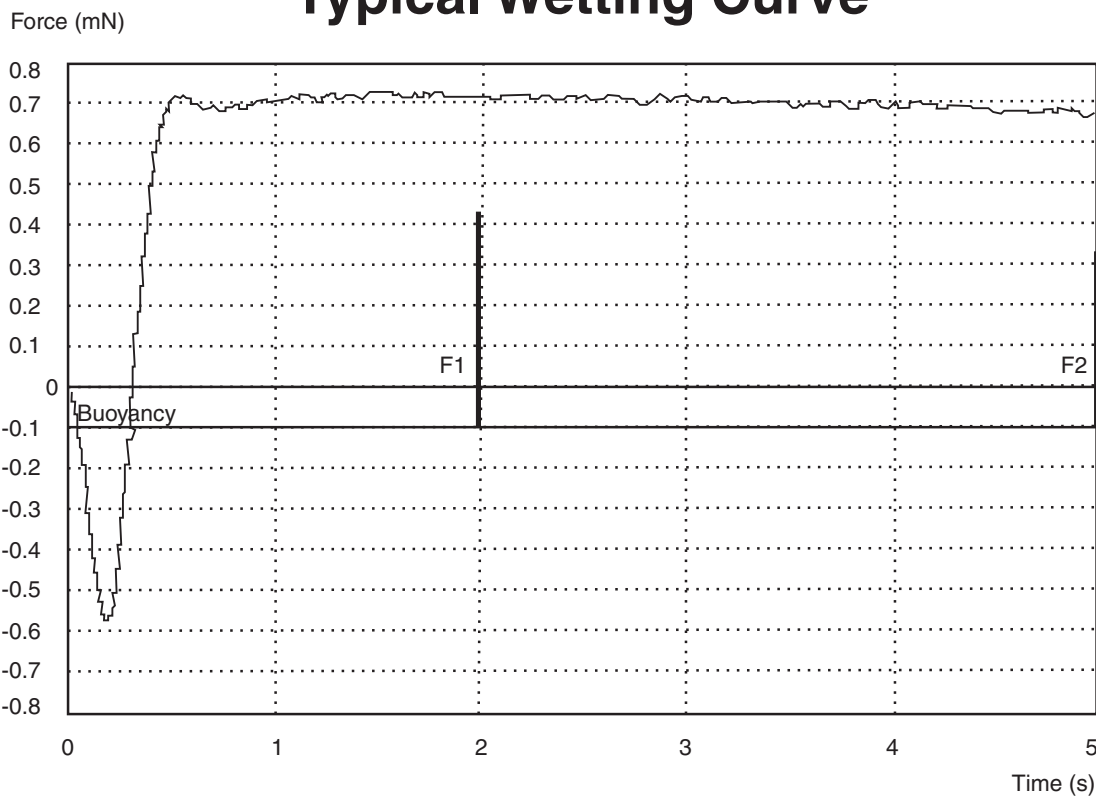

Appendix H

Test Protocol for Wetting Balance Gauge Repeatability and Reproducibility (GR&R) Using Copper Foil Coupons

1. All coupons for these tests **shall** be prepared individually just prior to testing. Do NOT batch clean the samples.
2. Copper foil of 35 microns nominal thickness (“1 oz” copper) **shall** be used for the test.
3. The copper foil **shall** have NO surface treatment and is expected to have an oxidized appearance upon receipt from the supplier. Do not use the copper foil if it is bright and shiny. This is indicative of surface anti-tarnish treatments being used. Surface treatments/preservatives can interfere with the ability to make a consistent “known good coupon” necessary for this test.
4. The copper foil coupons **shall** be die cut to ensure repeatability of the samples being tested and **shall** be of the following width dimensions;
 - a. 2 mm
 - b. 5 mm
 - c. 10 mm
5. Create a file for each foil width and for each individual person that is involved performing the GR&R.
6. Test parameters **shall** be:
 - a. Solder temperature **shall** be the as recommended for the alloy and the specification being used, i.e., for SnPb and ANSI-J-STD-003 it **shall** be 235 °C, for ANSI-J-STD-002 it **shall** be 245 °C. For SAC 305 it **shall** be 255 °C, regardless of the specification.
 - b. Immersion depth **shall** be 0.4 mm.
 - c. Immersion speed **shall** be 2 mm/sec.
 - d. Dwell time in the solder **shall** be 10 seconds.
 - e. Immersion angle **shall** be 90 degrees incident to the solder.
 - f. No preheat **shall** be used.
7. Sample preparation for the “known good coupon” **shall** be as follows:
 - a. Use a tweezers to immerse a foil sample into a beaker of Acetone and gently agitate for 20 seconds.
 - b. Remove sample and blot both sides dry with “Kim wipes” or other suitable lab tissue.
 - c. Again using a tweezers, immerse the above sample into a 20% v/v Nitric acid/DI water solution and gently agitate for 20 seconds.
 - d. Immerse the sample immediately into DI water and gently agitate for 20 seconds.
 - e. Blot the sample dry as in step “b” above.
8. Dip sample into the “standard activated flux” normally used for solderability testing for 5 seconds.
9. Holding the samples vertically, blot to remove excess flux.
10. Place sample into tool holder.
11. Run the test.
12. Repeat ten times for each foil width and each test person. It is recommended that three people should be used for the GR&R study.
13. For ease of data manipulation it is recommended to convert the wetting forces obtained into mN/mm of the coupon’s wettable length (perimeter). For example, the 10 mm wide coupon has a total wettable length (perimeter) = $[(2 \times 10 \text{ mm}) + (2 \times 0.035 \text{ mm})] = 20.07 \text{ mm}$.
14. For the “standard activated” flux of nominal 0.2% activation, the wetting force used for the calculations **shall** be 0.31 mN/mm. If a more active flux is being used, a large sample **shall** be run to obtain the mean value and this used for the calculations.
15. Calculate the standard deviation for each of the foil widths and the people running the test.
16. Multiply the standard deviation value by 6 (this represents the plus - minus 3 standard deviations of a normal distribution)
17. Divide this number by 0.31 and multiply by 100 to obtain a percentage value.
18. Tabulate the three values per person.
19. For an acceptable GR&R, the values obtained should be below 10%.
20. There should be excellent R&R results with the 10 mm coupon the first time this protocol is performed with an increasing spread from test person to test person when using the smaller coupons. The test may need to be repeated or individuals may require some “practice time” prior to running the full GR&R.
21. In addition to testing the individual, this protocol also tests the machine and will show linearity and any bias if it exists. Because the wetting forces have been normalized to mN/mm, the readings for each coupon width should be the same. If they are clearly different but the standard deviations produced by the individual test people are below 10%, then there is a problem with the wetting balance and the equipment manufacturer should be notified.



Standard Improvement Form

IPC/ECA J-STD-002C

The purpose of this form is to provide the Technical Committee of IPC with input from the industry regarding usage of the subject standard.

Individuals or companies are invited to submit comments to IPC. All comments will be collected and dispersed to the appropriate committee(s).

If you can provide input, please complete this form and return to:

IPC
3000 Lakeside Drive, Suite 309S
Bannockburn, IL 60015-1249
Fax 847 615.7105
E-mail: answers@ipc.org

1. I recommend changes to the following:

- Requirement, paragraph number _____
- Test Method number _____, paragraph number _____

The referenced paragraph number has proven to be:

- Unclear
- Too Rigid
- In Error
- Other _____

2. Recommendations for correction:

3. Other suggestions for document improvement:

Submitted by:

Name _____ Telephone _____

Company _____ E-mail _____

Address _____

City/State/Zip _____ Date _____

Association Connecting Electronics Industries



3000 Lakeside Drive, Suite 309 S
Bannockburn, IL 60015
847-615-7100 **tel**
847-615-7105 **fax**
www.ipc.org